

November / December 2010

## COMPRESSED AIR

# BEST PRACTICES®



## Compressor Control Systems

COMPRESSOR SEQUENCER  
PROBLEMS & SOLUTIONS

# Atlas Copco Compressors: The Air Auditing Specialists.



## Puzzled by rising energy costs?

Atlas Copco has a full range of compressed air auditing services available - from simple system diagnostics all the way to ultrasonic leak detection. These services are available for any compressed air system.

### A compressed air audit from Atlas Copco will:

- Show your compressor's energy usage.
- Highlight areas where savings could be made.
- Provide you with a payback analysis on any new investments.
- Provide you with a professional audit report.



Call Us: 866-688-9611

Log On: [www.atlascopco.us/mboxusa](http://www.atlascopco.us/mboxusa)

*Sustainable Productivity*

**Atlas Copco**

**HITACHI**  
Inspire the Next

# Ultimate Air Quality ISO 8573-1:2001 Class 0

**Class  
Zero**



Approaching 100 years of compressed air experience, Hitachi has been and continues to be the technology leader via continuous innovation of air compression oriented towards Customer Value. With growing concerns for the environment we live in, along with the products we consume, not only Oil Free, but Contaminant Free air is quite important.

The foundation of Hitachi Innovation is derived from more than 50 years of Oil Free Compressor technology, with the world introduction of Hitachi Oil Free Reciprocating compressors in 1954.

Continuing our pioneering spirit with societal responsibility, Hitachi embarked upon a certification of ISO 8573-1:2001 Class 0 for the Hitachi DSP Series Oil Free Rotary Screw Compressor (15-240kW). To validate our findings for consumer knowledge, third party laboratory testing was contracted with a positive result to standards, which enables Hitachi to provide a variety of Innovative, Technologically Superior, and Value Oriented Product for our Customers.

HITACHI AMERICA, LTD. AIR TECHNOLOGY GROUP  
5808-Q Long Creek Park Drive, Suite Q; Charlotte, NC 28269  
Tel: 704.494.3008 ext 28 [www.hitachi-america.us/airtech](http://www.hitachi-america.us/airtech); [airtechinfo@hal.hitachi.com](mailto:airtechinfo@hal.hitachi.com)  
Hitachi Industrial Equipment Systems Co., Ltd.

**100th**  
ANNIVERSARY  
Celebrating 100 years of the Hitachi Group

**HITACHI**  
Inspire the Next

## SUSTAINABLE MANUFACTURING FEATURES

**The System Assessment of the Month:** | 12  
**Compressor Sequencer Problems and Solutions**  
 By Tim Dugan, P.E., Compression Engineering Corporation

**The Technology Provider:** | 18  
**Starting a Long Distance Relationship  
 with Your Compressed Air System**  
 By James Green and Jay Johnson,  
 Ingersoll Rand Industrial Technologies

**Mattei Dresses Up a Textile Compressed Air System** | 22  
 By Compressed Air Best Practices®

**Demand vs. Supply, Parts I and II** | 26  
 By Scot Foss, Air's a Gas, Inc.

**Real-World Smart Sequencer® Controls** | 32  
 By Rod Smith, Compressed Air Best Practices®

**Energy Incentives:** | 35  
**PG&E's Third-Party Energy Incentive Programs**  
 By Compressed Air Best Practices®

**Compressed Air Controls** | 38  
 By Ron Marshall and Bill Scales  
 for the Compressed Air Challenge®

**The 2010 NAACD Conference & Exhibition** | 44



18



22



44

## COLUMNS

**From the Editor** | 5

**Sustainable Manufacturing News:** | 6  
 Atlas Copco, Ingersoll Rand, United Technologies Corporation

**Resources for Energy Engineers:** | 46  
 Training Calendar and Product Picks

**Wall Street Watch** | 48

**Advertiser Index** | 49

**The Marketplace** | 50



# FROM THE EDITOR

## Compressor Control Systems



System assessments are largely dependent upon compressor control systems taking advantage of the energy saving actions performed on the demand side of the system. It is particularly important for end users to remember that reductions in demand-side compressed air use will only be translated into energy savings, if the appropriate compressor technologies, and control systems, exist on the supply side. Since every compressed air system is unique, selecting the right compressor control system can be challenging. We hope this edition will help.

Tim Dugan of Compression Engineering Corporation, an independent system auditing company in the Northwest, provides the System Assessment of the Month for us. The article examines the real issue in the field of why so many sequencers are simply turned off after a period of time. Mr. Dugan provides us with good advice on how to avoid problems through proper system integration and controls design.

Ingersoll Rand has launched a new wave of system automation controls aimed at eliminating complexity from compressor coordination while reducing system waste and energy costs. The new Xi-Series makes monitoring “compressed air system health” simpler with some new visual gauges — making metrics, like kW per scfm, easier to access and manage.

Mattei Compressors has shared with us the process they went through to conduct a demand analysis for a textile plant in Mexico. The in-depth demand analysis, allowed the customer to select variable speed drive and fixed-speed rotary vane air compressors, in a configuration designed to maximize energy efficiency while providing remote monitoring and management capabilities.

To the question of matching demand-side actions with supply-side controls, Scot Foss provides us with a challenging article, “Demand vs. Supply”. An example is given of an installation, where compressed air consumption was reduced by 50%, yet there was only an 8% energy savings. This is an experience shared by all too many, and this article illustrates how the proper control strategy is not usually as obvious as it may seem.

Finally, we had the opportunity to interview the Third-Party Incentive Program managers at Pacific Gas & Electric. Responsible for roughly one third of PG&E’s overall incentive budget, this group illustrates how some customized compressed air incentive programs reach into market segments that their standard incentives don’t cover.

We hope you enjoy this edition. Thank you for your support and for investing in *Compressed Air Best Practices*® 

**ROD SMITH**  
Editor  
[rod@airbestpractices.com](mailto:rod@airbestpractices.com)



“It is particularly important for end users to remember that reductions in demand-side compressed air use will only be translated into energy savings, if the appropriate compressor technologies, and control systems, exist on the supply side.”

— Rod Smith  
Compressed Air Best Practices®

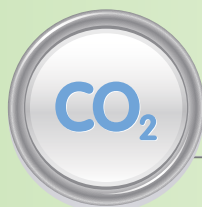

# SUSTAINABLE MANUFACTURING NEWS

## Atlas Copco, Ingersoll Rand, United Technologies Corporation

SOURCED FROM THE WEB



Ronnie Leten, President and CEO, Atlas Copco (Photo: Atlas Copco)



### Atlas Copco's Commitment to Sustainable Productivity

Atlas Copco's Sustainability Report is a yearly report prepared since 2001 in accordance with the Global Reporting Initiative (GRI) guidelines. Since 2006, the report has followed the GRI 3.0 version guidelines. This report is also Atlas Copco's Communication on Progress (COP), i.e. the report on the performance in relation to the ten principles within UN Global Compact.

The **Sustainability Report** covers all of Atlas Copco's operations for the fiscal year 2009, i.e., Atlas Copco and its subsidiaries, unless otherwise stated. Operations divested during the year are excluded, while units that have been acquired are included.

Atlas Copco had the self-declared GRI Application Level A confirmed by KPMG, which means that KPMG agreed that the content, page references and comments of the Atlas Copco Sustainability Report 2009 and GRI Compliance Index fulfills the GRI Application Level A.

Ronnie Leten, president and CEO, of Atlas Copco, commented, "Sustainability is not about being 'green,' although that is one of many important ingredients. For us, being committed to sustainable productivity covers a range of subjects: interacting with our customers, developing innovative products, having a good, diverse workplace for our employees, investing in competence development, engaging in our local communities and making safe, efficient products with a minimum of environmental impact."

TABLE 1: ATLAS COPCO GROUP PERFORMANCE SUMMARY(1)

GRI INDICATOR	ENVIRONMENTAL (PRODUCTION UNITS)	2005	2006	2007	2008	2009	TARGET
EN1	Material use in '000 tonnes (iron and steel)	82	85	143	138	104	—
EN1	Packaging material in '000 tonnes	26	31	35	44	26	—
EN3	Energy use in GWh	—	—	122	140	101	—
EN4	Energy use in GWh	—	—	258	276	251	—
EN3 + EN4	Energy use in GWh	311	321	380	416	352	—
EN8	Use of water in '000 m3	476	523	497	547	523	—
EN16	CO <sub>2</sub> emissions '000 tonnes (energy)	—	20	25	30	21	-10% (2013)
EN16	CO <sub>2</sub> emissions '000 tonnes (energy)	—	69	80	90	78	-10% (2013)
EN16	CO <sub>2</sub> emissions '000 tonnes (energy)	86	89	105	120	99	-10% (2013)
EN17	CO <sub>2</sub> emissions '000 tonnes (transports)	175	198	312	305	206	-10% (2013)
EN19	Cooling agents in tonnes	—	—	—	—	0.9	—
EN22	Waste '000 tonnes	23	27	35	38	27	—
GRI INDICATOR	ENVIRONMENTAL (SPECIALTY RENTAL)	2005	2006	2007	2008	2009	TARGET
EN3 + EN4	Energy use in GWh	—	40	65	27	17	—
EN8	Use of water in '000 m3	—	25	19	23	16	—
EN16	CO <sub>2</sub> emissions '000 tonnes (energy)	—	24	17	8	5	-10% (2013)
EN16	CO <sub>2</sub> emissions '000 tonnes (transports)	—	2	9	4	3	-10% (2013)

Source: [www.atlascopco.com](http://www.atlascopco.com)



# Bringing Out the Best..

in **Compressed Air Treatment Solutions** since 1948!

Hankison products are globally recognized for sustaining premium performance, reliability, and energy savings. Choose Hankison...**New** ideas...**New** products...after 61 years....still the best!



SPX Flow Technology  
TEL: 724 | 745 | 1555  
hankison.inquiry@spx.com  
www.hankisonintl.com  
www.spxft.com



# SUSTAINABLE MANUFACTURING NEWS

Atlas Copco, Ingersoll Rand, United Technologies Corporation

## Ingersoll Rand Sustainability

Energy conservation has become an increasingly important sustainability issue, from the impact of energy use on greenhouse gas emissions to the high costs of energy in today's markets. Ingersoll Rand is working to reduce energy consumption at our operations. Energy efficiency is a top priority for our own facility operations, as well as in our product development strategy.

The energy-saving actions implemented around our global operations include: energy audits involving facility staff and Trane professionals, installing timers on the power switches for building ventilation systems, promoting equipment maintenance procedures that improve efficiency, requiring staff to switch off all electrical equipment not in use and delivering additional employee training and information on energy-saving procedures. By reducing energy and associated greenhouse gases, Ingersoll Rand is becoming a greener, and more sustainable, company.

Ingersoll Rand facilities report energy use internally using the IREHS system on a monthly basis. In 2008, Ingersoll Rand used 5,351,557 gigajoules (1,487 million-kilowatt hours) of energy.

2009 GOALS AND PERFORMANCE		
METRIC	LONG-TERM GOAL	2009 PERFORMANCE
Energy	25% normalized reduction* over a 10 year period**	7% annual increase, normalized
Greenhouse gas (GHG) emissions	25% normalized reduction* over a 10 year period**	9% annual reduction, normalized

\*Normalized by revenue.

\*\*Baseline year for energy and GHG emissions is 2009.

### Focus on Energy Efficiency at Tyler, Texas

We are a leading provider of energy-efficient systems and solutions for buildings, and this same commitment to energy efficiency is vigorously pursued in our own facilities and processes. In 2007 and 2008, we instituted a comprehensive program to reduce energy consumption at Trane's largest production facility located in **Tyler, Texas**. Using detailed meter data and comprehensive analysis of facility infrastructure

conditions and needs, the energy team developed a phased plan that is expected to yield \$1.1 million in annual savings upon full implementation this year.

Tyler instituted a management focus on energy that included discussion of power consumption at every monthly management staff meeting. Electricity use data was collected from meters to allow for detailed analysis of energy demand throughout the facility. Wherever possible, facility components were monitored in terms of their kilowatt requirements per unit of output, and the engineering team sought out opportunities to improve performance against that metric.

At the outset of the project, the Tyler team also conducted a thorough assessment of infrastructure. Major systems included two compressed air systems, four chillers running in parallel, a process cooling tower and two gas-fired boilers. The team conducted a comprehensive evaluation of the facility demands on these systems and identified both operational adjustments and capital projects to better match capacity to demand. Some of the most significant cost savings will be realized by these conservation and efficiency measures that are now being implemented:

- Off-shift and weekend power management program, which turns off manufacturing equipment when not required
- Replacement of air compressor equipment to better match the load requirements
- Retrofits to install more high-efficiency fluorescent lighting
- Replacement of boiler with smaller, more efficient unit
- Revision of operating and maintenance practices associated with HVAC systems

Source: [www.ingersollrand.com](http://www.ingersollrand.com)



**Ingersoll Rand achieved a 9% annual reduction (normalized) in 2009 greenhouse gas emissions.**



# Sullair Compressors with EES Yield Quantum Cold Weather Savings

**Did you know . . .**  
Today's energy costs represent  
82% of the expense of  
compressor ownership.

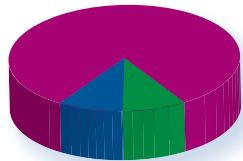

■ Equipment  
■ Maintenance  
■ Energy



## Save on Energy Costs

The Sullair compressors with Energy Efficiency System (EES) heat recovery were developed to produce the most cost-effective compressed air solution in the marketplace. The Sullair EES recovers the heat of compression and re-circulates it for comfort heating in plants for cold weather operations during winter months, or provides pre-heated air for boilers or processes. When not in use, the

thermostatic controls exhausts heated air to the outside. This 100 hp compressor generates 1,649,000 BTUs per year. Annual energy savings from the EES alone may reach \$10,993.00\*, with a payback period of 7 months as a result of the energy savings.

Additional energy savings may be achieved by combining the EES with Variable Capacity Control\*\* and Variable Speed Drive\*\*, which

provide flexibility to vary both capacity and pressure to match system demand, and result in maximum effectiveness in reducing total life cycle costs. Part load capacity and efficiency benefits can produce additional energy savings up to 17 percent.

*\* Calculations are based on climate conditions for Chicago, IL and natural gas at \$0.50/therm (subject to market fluctuations).*

*\*\* Not available on all configurations.*



# SUSTAINABLE MANUFACTURING NEWS

Atlas Copco, Ingersoll Rand, United Technologies Corporation



**UTC greenhouse gas emissions and water consumption decreased 23% and 25%, respectively, from the 2006 baseline.**



**United Technologies**



**SULLAIR**

*Always air. Always there.*

## United Technologies Corporation's 2009 Reports on Environment and Products

UTC is committed to measuring and reducing the impact of our operations and products on the environment. We have set aggressive conservation goals and have reported publicly on our performance since 1992.

Partnership and engagement with subject-matter experts support our environmental efforts. We partner with organizations such as the World Business Council for Sustainable Development, the World Resources Institute and the U.S. Environmental Protection Agency's Climate Leaders to understand environmental trends and the best ways to address them.

### 2009 Progress

- Reduce greenhouse gas emissions 3% annually and water consumption 2.5% annually from 2007 to 2010. Greenhouse gas emissions decreased 23%, and water consumption decreased 24% from the 2006 baseline. UTC remains on track to exceed the 2010 goals
- Invest \$100 million from 2007 to 2010 in energy conservation projects. Through year-end 2009, UTC approved \$116 million in energy conservation projects, including continued investment in new co-generation power plants under construction in Connecticut at Sikorsky's Stratford and Hamilton Sundstrand's Windsor Locks facilities
- Maintain compliance with environmental permits. In 2009, UTC conducted 118 independent compliance audits of our facilities worldwide. Actions to address risks were identified and systematically tracked to closure. UTC operations that were not scheduled for independent audits in 2009 conducted detailed permit reviews to validate compliance

### 2010 Objectives

- Reduce greenhouse gas emissions 3% annually and water consumption 2.5% annually from 2007 to 2010
- Continue to identify, fund and implement energy and greenhouse gas reduction projects beyond the \$100 million target
- Maintain compliance with environmental permits
- Prepare to launch both the next generation of greenhouse gas, air emissions, water and waste reduction targets, and the expanded set of goals for facilities, suppliers and products for 2011 through 2015

### UTC Products

UTC has a portfolio of products and services that deliver significant energy savings to our customers. Our fuel cells have been in use for nearly 50 years and today power everything from supermarkets to space shuttles. We also manufacture combined heat and power systems. Our geothermal products tap previously unusable geothermal reserves for renewable

and continuously available power. In 2009, UTC participated in working groups with the World Resources Institute and the World Business Council for Sustainable Development to draft the Product Life Cycle Accounting and Reporting Standard for Greenhouse Gases.

#### 2009 Progress

- Improve the energy efficiency and reduce packaging of new products by 10%. New UTC products released in 2009 improved in energy efficiency by an average of 25%. New products introduced included several Carrier chillers, new models of Otis' Gen2 elevators and the FlexiFOG micro water-mist fire suppression system from UTC Fire & Security. New product packaging was reduced by 23%, driven primarily by the redesign of packaging for Carrier and Otis products
- Continue to eliminate materials of concern in the manufacture and maintenance of all new products. UTC achieved a 51% reduction in new products released in 2009. This is down slightly from the 53% reduction in new products released in 2008

#### 2010 Objectives

- Improve energy efficiency and reduce new product packaging by 10% through 2010
- Work to eliminate materials of concern

Source: [www.utc.com](http://www.utc.com)



**A powerful force has arrived in the air compressor industry!**

## Introducing the CPG 375-475 HP

- **Install anywhere:** Standard low sound enclosure with small footprint
- **Save energy:** Optimize gear drive with water-cooled operation
- **Reliable:** Wye-delta, TEFC motor with intelligent microprocessor controller



**Join Our Successful Team**  
**1-877-861-2722**

[www.cp.com](http://www.cp.com)

**High-performance products.**  
**Designed for you!**



# THE SYSTEM ASSESSMENT OF THE MONTH

## Compressor Sequencer Problems and Solutions

BY TIM DUGAN, P.E., PRESIDENT, COMPRESSION ENGINEERING CORPORATION

As readers of this publication know, there are many ways to save energy in industrial compressed air systems. One common supply-side technology implemented is a “sequencer”. These can provide cost-effective savings. Unfortunately, many of them are turned off or are not running properly. The goals of this article are to show why sequencers often have problems and to demonstrate how avoid these problems through proper system integration and controls design.

### Introduction to Sequencers

Sequencers are control systems that sequentially stage multiple industrial compressor systems, running only the minimum number required, based on one pressure signal, usually with only one running in a part-load mode (“trim”) and the rest either fully loaded (“base-load”) or off. In this article, we describe three basic types of sequencers based on their algorithm: “cascade”, “target” and “custom”. The first two are for “discrete” control only using binary or relay interface and one best suited for load/unload screw or reciprocating compressors. Custom sequencers can be applied to proportional control, which includes variable speed (VS) and centrifugal compressors.

### Cascade Sequencers

The simplest sequencers use a “cascade algorithm”: the sequential starting and loading of compressors based on falling pressure and the reverse for rising pressure. This algorithm comes from the pre-computer age. Sequencers started their life as mechanically driven pressure switch selectors using relays, cams and timers. They work like this: as pressure drops, the next compressor starts and loads. As pressure drops further, the last compressor that is on unloads and stops. The sequencer swaps the order around to even out wear. This was coded into simple programmed logic when programmable logic controllers (PLCs) and embedded controllers were introduced to industry. The cascade algorithm is best suited for positive displacement and reciprocating compressors. Cascade sequencers have a wide operating pressure differential.

### Target Sequencer

With the advent of PLC and embedded controller technology, different algorithms have been designed. One common alternative to the cascade algorithm is the “target algorithm”. There are variants, but the simplest uses one pressure band for the trim compressor and a wider pressure band to trigger base-load compressors. The sequencer manages the number of base-load compressors running without having to wait for pressure to continue to drop again. The first time the pressure drops to the lower base-load point, the trim compressor is already fully loaded, and the #1 base starts. The second time it hits the same base-load point, the #2 starts, and so on. The reverse happens at the high limit of the wider pressure band but in reverse. Another way is to use timers instead of the wider pressure band to determine if the next compressor needs to start. Target sequencers have a narrow operating pressure differential.

# We Have Taken Multi-Tasking to a Whole New Level

Manage up to twelve positive displacement compressors simultaneously with our X-Series System Automation

**Including compressors of:**

- Different capacities
- Different types (fixed speed, variable speed and variable capacity)
- Different manufacturers
- And any combination or configuration

The X-Series System Automation products work with your existing compressors – Ingersoll Rand and/or any manufacturer!

- Improve operating efficiency
- Reduce energy costs
- Eliminate waste



**Ingersoll Rand's X-Series System Automation offers a window into your compressed air system with System Visualization.**

Complete system viewing from a local or remote PC has never been easier!

- Monitor critical system and equipment parameters
- Drill down to individual compressors to view operational status
- And be alerted to many warning and/or alarm messages

All done through a common web-browser , no special software to buy or maintain.



**The X8I and X12I feature Energy Control Mode which has the primary function to:**

- Match compressed air supply to compressed air demand, dynamically
- Utilize the most energy-efficient combination of air compressors to satisfy that demand

For more information on the X-Series System Automation and Visualization, please contact your local Ingersoll Rand representative or visit us on line at [ingersollrandproducts.com](http://ingersollrandproducts.com)



# THE SYSTEM ASSESSMENT OF THE MONTH

## Compressor Sequencer Problems and Solutions

These common designs seem simple. In a perfect world, implementation would also be simple. However, the simple sequencers previously described assume the following system characteristics for smooth implementation:

- All of the compressors are the same vintage, make, type and size
- All are in the same location
- All can run load/unload and be remotely started and stopped
- All are plumbed to a common header, generously sized, preferably before dryers
- There is adequate storage

Unfortunately, the systems in which they are being implemented often don't look like that.

### Custom Sequencers

The sky is the limit here, but we will comment briefly on three algorithms:

- Flow-Based — The optimal number and size of base-load compressors are run at any time based on total flow, not strict sequential order. A more advanced processor and algorithm is required. Significantly different sizes or types of base-load compressors make this algorithm a good fit
- Load-Sharing — Multiple proportional compressors are run at the same pressure and percent load. The management system “bumps” the local settings to make this happen. This expands the effective range of efficient trim operation, making a system more stable and reducing blow-off. Multiple (three or more) centrifugal compressors of similar size are a good fit for this algorithm
- Hybrid Base-Trim — Trim compressor(s) are run by either a cascade or target algorithm, sometimes at an elevated pressure and behind a pressure-flow controller. Base-load compressors are controlled by a separate algorithm and run at a lower pressure, often final system pressure. A good fit would be a mix of centrifugals and screws

### Common Sequencer Problems

1. Improper algorithm for the situation. For instance, cascade control for centrifugal compressors. This all but guarantees that one centrifugal will be in blow-off most of the time, wasting about 75% of its full load power.
2. Lack of a champion, leading to controls being defeated.
3. Control logic and wiring not changed when equipment is changed, particularly compressors.
4. Not all compressors are operating in “auto” properly. This can be caused by:
  - a. Incomplete or improper interface wiring and/or programming, most often on the compressor side.
  - b. Compressor is manually put in “local” for real or perceived reliability reasons.
5. Multiple compressors are in part load. Three common examples:
  - a. Incomplete integration: The minimum command is given to the compressor by the sequencer, “make air”. If the compressor is making little or no air because of local unloading or modulation, the sequencer will start and load the next compressor at part load. The sequencer is “unaware” of this.
  - b. Improper local setting: The local modulation settings are in the same range as the sequencer settings. The sequencer starts the compressor once, but pressure never gets high enough to unload it. The local settings reduce capacity first. Then, another compressor ends up being called to start when demand increases. The sequencer is “unaware” of this also.
  - c. Compressors far apart: Local controls trigger a compressor to operate out of phase with master control input, which is far away from it.



**In this article, we describe three basic types of sequencers based on their algorithm: “cascade”, “target” and “custom”. The first two are for “discrete” control only using binary or relay interface and are best suited for load/unload screw or reciprocating compressors. Custom sequencers can be applied to proportional control, which includes variable speed (VS) and centrifugal compressors.**

6. Short cycling (rapid loading/unloading). This can cause oil carryover in oil-flooded screw compressors and reliability problems with oil-free screw and centrifugal. It has a variety of causes:
- Operating pressure differential too tight.
  - Inadequate control storage, causing rapid pump-up and bleed-down times.
  - Excessive pressure differential across treatment equipment. Effective compressor control band is reduced by the dynamic pressure drop across the treatment. This often is caused by a compressor being isolated behind an individual restrictive dryer and filter.
  - Different local and sequencer control points. The sequencer might be using pressure downstream from the dryer and the compressor unloads based on a pressure upstream.
7. Excessive motor starts. This can damage the motor. Besides the short cycling issues, it can be caused by:
- Timers in sequencer either not adjusted properly or unable to be adjusted.
  - Sequencer not tuned properly.

# EDMAC

Shopping for air compressor parts,  
*made simple*



- A world class team of experts with technical knowledge and professional experience
- The industry's best search and cross-reference capabilities
- The EDMAC Guaranteed Price Promise



701D E. Salem Ave. Winston-Salem, NC 27101  
 Phone: 336-722-1878 • Fax: 336-722-9313  
 Toll Free: 1-877-43EDMAC  
 E-mail: sales@edmac.com

## THE SYSTEM ASSESSMENT OF THE MONTH

### Compressor Sequencer Problems and Solutions

8. Improper integration of a VS compressor. This can cause the following:
  - a. The VS compressor is controlled in a discrete manner, it could either base-load (full speed), shut off or run uncontrolled depending on the settings. All VS compressors control their own speed by their internal controls, so a simple sequencer is usually unaware of these problems.
  - b. The VS could hunt, “chasing” the compressor that is being loaded and unloaded by the sequencer. Lack of storage, tuning or location of compressor could cause this.

#### Problems Unique to “Vendor Sequencers”

Since these are designed and sold by compressor companies, they are usually intended for integration with all new compressors from the same manufacturer. They are typically based on proprietary code running on low-cost embedded controllers and usually use some form of either cascading or targeting. Some of the lower cost sequencers are what I call “told you to make air” controllers, with no feedback that the compressor is actually doing that. Most vendor sequencers don’t incorporate intelligent feedback for running, load or fault. Some incorporate monitoring, but only at points that are already monitored by the compressor controller. They are often low cost (less than \$10,000) and appear simpler to implement than other options. Some unique problems are:

- Sequencer is sold as a component on a project, with no integration service. Underselling is a perfect way to have under-performance
- The compressors don’t have the same vintage control panels and interfaces. Oftentimes, these sequencers require an up-to-date controller on all the compressors, or the interface becomes quite primitive. You either get the entire interface or just a single “told you to make air” contact and not much in between
- The algorithm is not known to the field engineer and customer. Proprietary controllers try to be too smart. Unfortunately, if you don’t know its basic logic, you can’t get it adjusted properly

#### Problems Unique to “Third-Party Sequencers”

These are sequencers that are designed and sold by third parties, often PLC-based open architecture. They have a pre-programmed algorithm that is adapted to each site. They typically have relay interface or a generic network interface that has to be programmed or adapted

in each case. Some are customizable for customer networks, data collection, etc. They are typically mid cost (\$10,000 to \$25,000 before customization). They usually come with a field engineer start-up included. Some unique problems are:

- Supplier might not understand compressor issues well. Their strength in controls knowledge can be offset by their lesser understanding of the compressors themselves
- Sequencer might not be able to interface with compressor controller’s full communications capability
- Supplier has little local support after project is completed, e.g., it is made by a small company that has a thinly-stretched field engineering staff

#### How to “Do Sequencers Right”

Here are our recommendations for a successful sequencer project that continues to work for the life of the system.

1. Don’t call it a sequencer. That implies it is a simple add-on component, which it certainly is not. It is an integration project that happens to have master controls as a part of it. A better term for it is a “compressed air management system”.
2. Identify a project champion in-house who has some understanding of controls and of the compressed air system.
3. Select a controls architecture that is best suited to manage the compressed air system. Keep in mind that compressed air is an essential utility that is very expensive to operate, and even more expensive if it fails. Skimping on controls, and particularly monitoring, can end up being a bad decision in the long run.
4. Perform a system audit first. Assess the existing system in as much detail as is cost-effective. We recommend the following:
  - a. Data-log compressor room primary variables for about one to two weeks.
  - b. Calculate total compressed air flow profile, total power and system efficiency (acfm/kW).
  - c. Develop several alternative project concepts — from retrofit controls to new equipment, depending on budget.
  - d. Develop a preliminary compressed air management system specification. Some compressor vendors are qualified to do this. Independent auditors have significant value as well.



5. Select the best firm to design and install the compressed air management system based on the architecture issues and audit results.
6. Develop approval drawings for the management system, and review them. This should include a written sequence of logic.
7. Select a contractor to install the management system. They need to be capable of working closely with the auditor, local electrician/engineer, management system supplier and compressor vendor. If other mechanical issues are being done at the same time (storage, piping, dryers), consider making them a subcontractor to one turn-key contractor.
8. Get compressor interfaces identified and modified first. Test them to make sure they are all ready to be controlled by the management system.
9. After approval, build and program the management system.
10. Have all mechanical and instrumentation issues completed and tested.
11. Deliver the management system.
12. Land wires and/or network, test interfaces and start up the system. It should be run through failure modes and exception modes sufficient to tune the system.
13. Collect data for at least one week and deliver it to the management system supplier or auditor for review. If possible, allow them to have direct remote access to pull data, either through the plant HMI system or a GSM modem.

14. Develop a tuning/commissioning report based on this data.
15. Perform final tuning.
16. Document the system well. A three-ring binder in the maintenance and system champion's office. At a minimum, include an overall P&ID, electrical schematic(s) for controller and interface wiring and written sequence of operation.
17. Hang an engraved sign on the wall near the controller with the approved set points.
18. Train the champion and operators.

The most important issues that affect compressed air management system performance are people and business related. Are the right people doing the right thing with the right technology at the right price in the right way and in the right sequence? Implement an integration project properly, and the sequencer will have a much better chance of working properly. **BP**

For more information, please contact Tim Dugan, P.E., Compression Engineering Corporation, Tel: 503-520-0700, or email: [Tim.Dugan@compression-engineering.com](mailto:Tim.Dugan@compression-engineering.com), [www.compression-engineering.com](http://www.compression-engineering.com).

Motorized Ball Valves



Magnetic Zero Air Loss Drains



Electronic Zero Air Loss Drains



Timer Drains



Compressed Air Leak Detector



Oil Water Separators



## THE CONDENSATE MANAGEMENT SPECIALISTS

JORC offers a product range that covers ALL condensate requirements. We provide total quality and reliability so that you don't have to compromise—our range of versatile and cost-effective solutions are designed to meet all of your condensate management needs. Through continued investment in research and development, we offer up-to-date solutions that you can count on.

*At JORC we never compromise on Quality or Reliability—why should you?*

Contact us today:

**JORC Industrial LLC.**

1146 River Road • New Castle, DE 19720

Phone: 302-395-0310 • Fax: 302-395-0312

E-mail: [info@jorc.com](mailto:info@jorc.com)

See our new online catalog at  
**[www.jorc.com](http://www.jorc.com)**

**JORC**



# THE TECHNOLOGY PROVIDER

## Starting a Long Distance Relationship with Your Compressed Air System

BY JAMES GREEN, PRODUCT MARKETING MANAGER AND JAY JOHNSON, PORTFOLIO MANAGER FOR CONTROLS & AUTOMATION, INGERSOLL RAND INDUSTRIAL TECHNOLOGIES

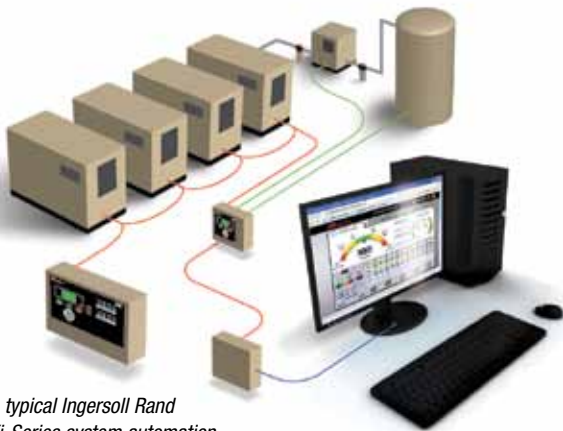

A typical Ingersoll Rand Xi-Series system automation installation



According to the United States Department of Energy, roughly \$1.5 billion is spent annually generating compressed air in the U.S. Between 20% and 50% of this energy is wasted. One of the primary drivers behind such waste in systems with multiple compressor units is misalignment between system supply and demand.

When was the last time you visited your compressor room? A week ago? Several weeks ago? If you are like many, you went in for the last scheduled maintenance interval and have rarely been back since. With each new generation, air compressors, dryers and other air system components have become more reliable and self-sustaining from a maintenance standpoint, requiring less and less human intervention. This progress has been extremely beneficial. Less direct involvement frees maintenance staff to focus on other plant issues and reduces the overall cost of compressed air. However, out of sight can mean out of mind. Unmonitored compressed air systems can fail, leading to substantial production delays or work stoppages. Even compressors that are operating reliably can waste significant amounts of energy if they are not properly controlled. Air system components that are not optimized to function as a system may not be running efficiently. With the rising cost of energy and limited resources, effectively managing a compressed air system remains a challenge, leaving many looking for new ways to:

- Effectively manage multiple compressors for maximum energy efficiency
- Monitor compressed air system health without investing significant time or effort
- Ensure optimized compressed air systems continue to run efficiently and reliably over time

### Managing Multiple Compressors for Maximum Energy Efficiency

Energy figures prominently in most industrial environments, and the compressed air system is typically one of the largest consumers of energy in any given facility. According to the United States Department of Energy, roughly \$1.5 billion is spent annually generating compressed air in the U.S. Between 20% and 50% of this energy is wasted.<sup>1</sup> One of the primary drivers behind such waste in systems with multiple compressor units is misalignment between system supply and demand.<sup>2</sup>

<sup>1</sup>U.S. Department of Energy, Industrial Technologies Program, "Compressed Air" [http://www1.eere.energy.gov/industry/bestpractices/compressed\\_air.html](http://www1.eere.energy.gov/industry/bestpractices/compressed_air.html), (accessed October 5, 2010).

<sup>2</sup>United States, Department of Energy, Office of Industrial Technologies, *Compressed Air System Control Strategies*. (Washington: OIT, 2004) 1.



“At the pace of work today, our customers can’t afford to think much about their compressed air system, so we created the Xi-Series system automation controls to automate most of the work, and alert operators when there is a need.”

— Randall Finck, Global Category Manager at Ingersoll Rand

Adding system automation controls like Ingersoll Rand’s Xi-Series can help eliminate the complexity of compressor coordination and ensure that your compressed air system is properly optimized to help reduce system waste and related energy costs. These systems continually monitor and learn the air system demand requirements, then use advanced algorithms to dynamically determine the most energy efficient compressor or combination of compressors to meet current system demand levels. The system control manages the air system pressure at the minimum pressure required, operating compressors only as needed and bringing standby compressors on line incrementally during peak demand, all without compromising air supply reliability. Some advanced system automation controls, like the Ingersoll Rand Xi-Series, also allow the operator to control both variable-speed compressors and fixed-speed compressors to minimize wasted energy due to unloaded compressor run-on time or short-cycle operation. System controls that can manage compressors of different capacities, types (fixed speed, variable speed and variable capacity) or brands will help ensure that all compressors in the system are efficiently controlled for maximum energy savings while maintaining or even improving productivity levels.

Adding system control to your compressed air system does not prevent manual access to the compressed air system. While the system controller employs advanced algorithms

to effectively manage the system, Xi-Series automation will allow users to drill down to individual compressors for troubleshooting purposes or individual level control. “At the pace of work today, our customers can’t afford to think much about their compressed air system, so we created the Xi-Series system automation controls to automate most of the work, and alert operators when there is a

need,” said Randall Finck, Global Category Manager at Ingersoll Rand.

### Monitoring Your Compressed Air System Made Easy

In addition to reducing energy costs, some system automation controls can provide a greater level of insight into and remote access to the compressed air system, enabling a more

## ALMiG Oil-Free Compressed Air

When your application or your product requires oil-free air, the LENTO range is the perfect compressor! Hospitals, electronic industry, food processing, pharmacy – wherever CLASS 0 air is required ALMiG should be your first choice!

- variable speed technology
- direct coupled
- integrated air dryer
- 20hp up to 110hp
- 145 psi max
- 100% oil free
- air and water cooled
- tested & certified by Fresenius



**ALMiG**  
since 1923

ALMiG USA Corporation • Green Bay, Wisconsin  
Sales@AlmigUSA.com • Toll free: 866.992.5644

## THE TECHNOLOGY PROVIDER

Starting a Long Distance Relationship with Your Compressed Air System



The Ingersoll Rand Xi-Series System Visualization Module provides operators with intuitive, graphic-based control of their compressed air system

“The remote visibility provided by the Ingersoll Rand Xi-Series automation system allows me to keep close tabs on my compressed air system and proactively deal with issues before they affect production. I also appreciate the savings, both in energy and manpower.”

— Gary Gingras, Facilities Manager, TurboCare, Inc.

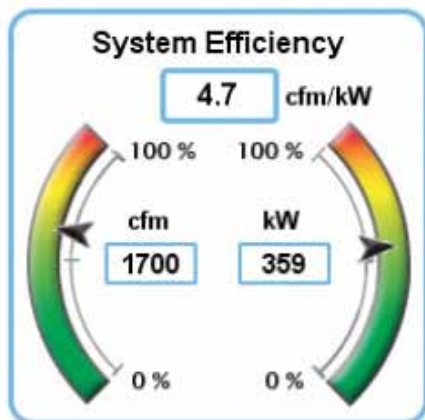

The Ingersoll Rand Xi-Series System Visualization Module provides useful efficiency gauges to help monitor energy consumption



The Ingersoll Rand Xi-Series Visualization Module provides graphing of key performance data over time to help effectively monitor system performance

proactive approach to system maintenance and optimization. By capturing operational information from each machine and presenting it in one, easy-to-understand dashboard in a central location, system automation tools eliminate multiple trips to each compressor to gather performance information and make system adjustments or monitor system status, reducing the labor burden on maintenance staff. With technology advances, today's modular control systems provide many of the advanced functions that used to be available only with custom-built systems at substantially reduced prices. Some customers have been able to cover the cost of a new system control in less than six months with their energy savings alone.

Using system control features like the Ingersoll Rand Xi-Series web-based Visualization Module, operators can fully view their entire compressed air system and change key parameters as needed. Some system controls, like the Xi-Series, can even send automatic email alerts, ensuring the right individuals are immediately notified whenever compressor settings are changed, abnormal operating conditions occur or when equipment has been shut down, regardless of whether they are located on-site or across town. This ensures that potential problems are resolved quickly to prevent or minimize downtime. “The remote visibility provided by the Ingersoll Rand Xi-Series automation system allows me to keep close tabs on my compressed air system and proactively deal with issues before they affect production,” said Gary Gingras, Facilities Manager, TurboCare, Inc. “I also appreciate the savings, both in energy and manpower.”

Setting up remote access and control can seem like an intimidating task. However, system controllers are becoming increasingly user friendly. For example, the Ingersoll Rand Xi-Series provides multiple connection options to fit a wide range of facility needs, including Modbus RS485 and Ethernet ports. This provides the user with the flexibility to choose the simplicity and freedom of an Ethernet connection or integration with an existing Distributed Control System (DCS).

## Maintaining Efficiency Gains and Energy Cost Savings

Optimizing compressed air system operation is often only half the challenge. The other is measuring and maintaining these improvements and savings over time. Fortunately, some advanced system controllers feature built-in performance reporting capabilities that can help accomplish this. For example, the Ingersoll Rand Xi-Series Visualization Module automatically records key operating parameters, compiles the data to a reporting format and provides access via a web browser on the facility's Local Area Network (LAN).

One common efficiency loss occurs when end-use compressed air demand changes significantly, which can drive down overall system efficiency. To help operators notice these types of changes, the Xi-Series includes useful efficiency gauges that measure useful parameters such as kilowatts used per unit of air flow on the visualization dashboard. Anyone who is monitoring this parameter over time will see that something has changed, even though everything may still be working fine. By graphing key parameters like system flow over time, the Xi-Series Visualization Module makes it easy to notice and respond when demand is up, system pressure is averaging high or compressors are being turned on or off more frequently. Data can easily be emailed or exported to standard software like Microsoft Excel for further analysis, enabling users to remotely optimize and maintain the performance of their system.

Another frequent occasion where efficiency is lost occurs with staff changes. If a new employee cannot quickly grasp a compressor's status or understand how to use the system controller, it may be turned off the first time that something appears to be wrong. The simplest solution to this problem is to select intuitive system automation controls. For example, the Xi-Series Visualization Module

software features clear, graphic-based screens that offer at-a-glance system updates and quick access to critical compressor controls — virtually eliminating the learning curve. All system menus are arranged on easy-to-follow tabs and control icons are easily identifiable. In addition, the system can be accessed from any web-based browser and requires no special software. With streamlined access to compressor controls and clear information about the compressed air system, intuitive controllers like the Ingersoll Rand Xi-Series prevent operators from wasting time figuring out how to manage the system and allow them to focus on delivering efficiency gains and energy cost savings.

There is an ever-increasing responsibility being placed on those managing compressed air systems to mitigate risks, optimize processes to meet sustainability goals and save money. By combining simple remote connectivity options with clear and actionable information, an automated control system is a simple, practical way for operators to provide sustained savings in energy and efficiency for their compressed air systems — all without having to physically visit the compressor room. **BP**

For more information contact Jay Johnson, Ingersoll Rand, at Tel: 704-896-4013 or email: [Jay\\_Johnson@irco.com](mailto:Jay_Johnson@irco.com), [www.ingersollrandproducts.com](http://www.ingersollrandproducts.com).

## COMPRESSED AIR IS ENERGY Make sure it's not going to waste.

Our low-cost, easily-installed flowmeters are changing the way people manage their compressed-air systems. Metering branch lines reveals savings opportunities and ensures that once savings are achieved, they are maintained. Compressed air does not have to be invisible.



**cdimeters**

[www.cdimeters.com](http://www.cdimeters.com)

Phone: 781-935-9600 Toll free (US and Canada): 866-885-2462



# Mattei

## Dresses Up a Textile Compressed Air System

*Four Mattei Air Compressors  
Installed in Northern Mexico*

**BY ROD SMITH,  
COMPRESSED AIR BEST PRACTICES®**

A brand new textile facility located in northern Mexico recently finished the installation and start-up of their new compressed air system. After a thorough analysis of the requirements of the compressed air system, Mattei Compressors supplied the system components. “Mattei was chosen as the supplier due to the customer’s experience with the durability of our rotary vane air compressors,” commented Mattei USA general manager Jay Hedges, “and due to the effort our team put forth to design a system optimized for energy efficiency.” Mr. Hedges continued, “We took great care of this key account by harnessing the best talent out there. In this case, it included Mattei corporate engineering staff in Italy, our distributor LANS in Los Angeles, iZ Systems on system auditing and flow-control valves and Airleader for the compressor management system.”

### Running a 630 kW Installation at Slow Speeds

This new 898,000 square foot facility, located on over 20 acres in northern Mexico, is the most recent addition to the growing network of production facilities owned and operated by this successful textile corporation. Once a small single-factory knitting operation, the corporation has used Mattei air compressors for many years in different facilities around the world. They currently operate over 30 Mattei air compressors — with some of them running for over 18 years — and still counting. As Bill Kennedy, Mattei’s sales and products manager, stated, “This customer places a high value on durability — they have experienced great reliability during these 18 years with their Mattei air compressors.”

Running air compressors at fewer revolutions per minute (RPM) increases the life of the air end. The installation at this textile plant consists of three MAXIMA Series fixed-speed, single-stage, rotary vane air compressors working as the base-load air compressors. There are two 160 kW and one 110 kW MAXIMA machines. The trim air compressor is a 200 kW OPTIMA variable speed drive, single-stage air compressor. “The fixed-speed MAXIMAs run at 1,200 RPM and the OPTIMA will run in a range between 800–1,700 RPM,” according to Mr. Kennedy, who also added, “The durability of Mattei rotary vane air ends is reflected by their 10-year factory warranty.”

### Knitting Machines and Sewing Cells

The textile plant made it clear that they wanted the most energy efficient compressed air system possible — without sacrificing air quality and durability. All too often, compressed air installations are poorly designed from the very start and, almost always, the root cause of this problem is that the demand side of the system is not understood. iZ Systems, a leading independent compressed air auditing firm, was invited by Mattei to take a look at the project. Dean Smith, a Senior Auditor from iZ Systems commented, “This textile plant uses compressed air in their knitting, sewing and dye house operations and needed a system designed for the significant fluctuations in demand.” Compressed air demand profiles were placed into four segments: 1st shift peak demand and minimum demand and 2nd shift peak demand and minimum demand.



The Mattei OPTIMA 200 variable speed drive compressor

The analysis provided detailed end-use information critical to designing an optimized system. Mr. Smith explained further, “Analyzing the amount and rate of variation in air demand is critical to analyzing the turndown requirements of the compressed air supply equipment, to make sure that efficiency is maintained in all conditions.” The demand-side analysis at the textile plant identified a peak demand of 4,500 cfm and a minimum demand of 2,700 cfm. Further, the analysis identified exactly where and at what times these demand fluctuations were occurring — and at what pressure. Header piping was designed and storage was strategically located to insure that the system pressure would be stable.

- Three hundred knitting machines using 7 cfm (at 60 psi) each during the first shift
- 50 sewing cells using 28 cfm (at 80 psi) each during all three shifts
- Dye house demand range between 400–1,000 cfm (at 90 psi) during all three shifts

TABLE 1: UNDERSTANDING AIR DEMAND AT THE TEXTILE PLANT			
Knitting	2,100	1st shift	Peak Demand
Sewing	1,400		
Dye House	1,000		
Total	4,500	(2) Max 160s, (1) Max 110 and (1) Opt 200 @ 100% = 4,500	
Knitting	2,100	1st shift	Minimum Demand
Sewing	1,400		
Dye House	600		
Total	4,100	(2) Max 160s, (1) Max 110 and (1) Opt 200 @ 65% = 4,200	
Knitting	2,100	2nd and 3rd Shift	Peak Demand
Sewing	—		
Dye House	1,000		
Total	3,100	(2) Max 160 and (1) Opt 200 @ 56% = 3,100	
Knitting	2,100	2nd and 3rd Shift	Minimum Demand
Sewing	—		
Dye House	600		
Total	2,700	(1) Max 160, (1) Max 110 and (1) Opt @ 55% = 2,700	

Note: each fixed-speed MAXIMA runs at full demand in each scenario above, using the OPTIMA 200 as trim, from 55% to 100% of full load capacity

**WALKER**  
FILTRATION  
The ultimate filtration & drying technology



### Manufacturers of Drying and Filtration Equipment for Compressed Air, Gas, Medical Sterile and Vacuum Applications

Below you will see just a few examples of our products.



Heatless Desiccant Dryer



High Pressure Stainless Steel Filter



Alternative Filter Elements

- Superior operating performance, saving energy and money
- Manufactured to the highest quality standards
- Threaded Filter Housings are 100% Pressure Tested
- Competitive Pricing
- Vast Inventory of Product
- Over 25 years in filtration industry
- Full technical, sales and service support
- Alternative Elements are guaranteed to provide equal to or better performance than the original equipment

For a special offer please reference WALKER1110CABP when you call us to place an order.

www.walkerfiltration.com  
Tel: +1 (814) 836-2900  
E-mail: usa@walkerfiltration.com

# MATTEI DRESSES UP A TEXTILE COMPRESSED AIR SYSTEM



## Contaldi Family Commits to Mattei's Future

Entering the 91st year of the company's existence, the shareholders of ING ENEA MATTEI S.P.A. appointed a new board of directors this past February 2010.

The individuals appointed were:

- President Carla Luisa Lucca Contaldi
- Chief Executive Officer Giulio Contaldi\*
- Chief Financial Officer Silvia Contaldi\*

\* pictured above



OPTIMA 200 variable speed drive air compressor delivers 1,251 cfm and its inverter-based VSD system allows for optimal turndown capabilities with loads between 40–80%. Outlet compressed air retains no more than 3 ppm of oil in the air due to mechanical separation followed by a coalescing air/oil separator.

According to the CAGI Data Sheets supplied on the fixed-speed MAXIMA 110 and 160 models, the “Specific Package Input Power at Rated Capacity and Full Load Operating Pressure” of the machines is as follows:

- 16.65 kW/100 cfm for the MAXIMA 160 at 1,206 acfm rated capacity at full load operating pressure of 101.5 psig
- 17.46 kW/100 cfm for the MAXIMA 110 at 847 acfm rated capacity at full load operating pressure of 100 psig

According to the CAGI Data Sheets supplied on the variable speed drive OPTIMA 200 model, the performance is as follows with (1) full load and maximum full flow operating pressure of 101.5 psig (2) drive motor and fan motor nameplate ratings of 275 hp and 5.1 hp respectively (3) drive motor nameplate efficiency of 96.4%:

OPTIMA 200		
INPUT kW	CAPACITY (Cfm)	SPECIFIC POWER kW/100 Cfm
107.07	647.5	16.54
133.88	782.7	17.1
161.93	917.3	17.65
191.24	1,051.3	18.19
206.40	1,118.0	18.46
237.60	1,251.40	18.99

## The Compressor Management System

The textile firm wanted to be able to monitor and control the compressed air installation from a remote location. They also wanted to monitor energy consumption and make sure the system continues to operate at the levels specified by the system design.

Here again, Mattei called in Airleader, a leading German manufacturer of air compressor management systems, to optimize this piece of the system. Jan Hoetzel of Airleader was brought in from the North American corporate office.

The Airleader has the role of a conductor, making sure that the most efficient compressor mix is selected following dynamically the demand of the various shifts. Connecting to the on-board MAESTRO controls of the four different Mattei air compressors was easy since all the needed ports inputs/outputs were already pre-wired.

The Airleader compressor management system also has a standard web-based software package providing the plant engineers at the textile plant with the reports they are looking for on energy consumption, performance data, air flow, pressure and pressure drop. Optionally, the system can also send alerts via e-mail if a compressor is down or a system parameter is not met.

AIR COMPRESSOR SELECTION			
	QUANTITY	CFM EACH	TOTAL CFM
MAXIMA 160	2	1,201	2,402
OPTIMA 200	1	1,251	1,251
MAXIMA 110	1	847	847
		Total	4,500

## Rotary Vane Air Compressor Efficiency to 16.54 kW per 100 scfm

The four Mattei rotary vane air compressors were chosen so that the minimum amount of horsepower required would be online during the four different flow profiles. The fixed speed, single-stage MAXIMA models were the 160 and the 110. They were chosen so they could run at full load and achieve energy efficiency levels as low as 16.54 kW per 100 cfm. The MAXIMA and OPTIMA models run twin airends in parallel at the slow speeds of 1,200 RPM for the MAXIMA and less for the OPTIMA. A single Servovalve assembly that balances the inlet flow to both compression modules manages air delivery regulation. The



The Maestros XS On-Board Controller



**Compressed Air Treatment and Flow Management**

The removal of moisture, particulates and oil from compressed air is critical in the textile industry to protect the end product from becoming damaged and experiencing unacceptably high product rejections. Clean and pure compressed air (at the right pressure) is also critical to ensure the optimized output of the knitting machines and sewing cells. The specification called for ISO 8573.1 Quality Classes 1.4.1 for compressed air quality.

To accomplish this, two Zander ASD 2400 cycling refrigerated dryers with microfilters were installed to provide a 38 °F pressure dew point. Due to the presence of fluctuations in compressed air demand between 2,700 and 4,500 cfm, cycling-type refrigerated dryers were chosen to reduce the energy consumption of the air dryer’s refrigeration compressors during the partial load conditions.

Filtration requirements were fulfilled by a prefilter and 0.01 micron coalescing filters. Condensate collection was taken care of by five Bekomat, 16 zero air-loss condensate drains connected to the dryers, filter and air receivers. The condensate is then routed to a Beko Owamat 8 oil-water separator, which purifies the condensate before it is released to the drainage system.

Three flow control valves, supplied by iZ Systems, work together with eight 1,060 gallon air receivers to ensure that the three main production areas receive enough compressed air at the right pressure. They also reduce the number of start/stops required by the air compressors by providing a buffer to sudden increases in compressed air demand.

**Up and Running**

The plant is up and running and all is well, according to Mattei USA general manager Jay Hedges. “The textile plant experienced a flawless start-up and the compressed air system is up and running,” he says. Apparently, things are also up and running at Mattei USA as Mr. Hedges continued to comment, “Our business in 2010 has increased significantly as Mattei continues to successfully introduce the rotary vane air compressor models ranging from 5–250 horsepower into North America.” 

For more information, please contact Rod Smith at Compressed Air Best Practices® at: [rod@airbestpractices.com](mailto:rod@airbestpractices.com) or [www.airbestpractices.com](http://www.airbestpractices.com), or contact Mattei Compressors at [www.matteicomp.com](http://www.matteicomp.com).



**Engineering Your  
Toughest Applications**

Aircel engineers the compressed air technology your environment needs, while keeping your footprint, energy costs, and maintenance top of mind.



HRE Desiccant Series  
(600 - 10,000 scfm)



VF, DHT, AR Refrigerated Series  
(10 - 10,000 scfm)

**Optimal Compressed Air  
System Performance**



HRS-L Desiccant Series  
(600 - 10,000 scfm)



RTM Refrigerated Series  
(2,500 - 30,000 scfm)



Aircel has Compressed Air Dryers, Filtration Systems, Separators, Drains, Aftercoolers, Analyzers, Chillers, Coolers, and more available.

Find more at [www.AircelCorp.com](http://www.AircelCorp.com)  
or call (800) 767-4599



[www.AircelCorp.com](http://www.AircelCorp.com)

PHONE  
(800) 767-4599  
FAX  
(865) 681-7069  
SALES  
[sales@aircelcorp.com](mailto:sales@aircelcorp.com)

323 Crisp Circle

Maryville, Tennessee

37801

# DEMAND VS. SUPPLY

BY SCOT FOSS, AIR'S A GAS INC.

## Part I

One of the problems I have witnessed over the 38 years that I have audited air systems is the lack of understanding of the relationship between supply and demand. Many an estimate of final results after an aggressive action plan either do not make ROI or provide a short-lived solution. The purpose of this article is to investigate the cause and effect that can occur when you reduce demand with no supply changes, and the alternative, which produces positive, long-term results that you can take to the bank.

### A. A 25% Demand Reduction — With No Supply Adjustment

Let's say that you have discovered that you have 24.4% of the total 1000 scfm demand in the system in leaks and another 20% in open blowing applications. You estimate that this equals 45% in waste of all of the air usage. Your action plan says that you will tag all of the leaks and fix 60% of them. You will also replace the open blowing applications with high-efficiency, low-volume hand-held and stationary blowing devices. The intent is to reduce open blowing by 50%. This sounds like a no brainer. Reduce the total usage by 25%. If you have five 282 scfm compressors with five on and no standby, it's easy picking to get one unit off-line...right?! Lets first look at a process flow diagram in Illustration #1 (on page 28).



In a study we did for the American Council for an Energy Efficient Economy some years ago, we determined that in most cases, 80% of all usage in the 27 systems we audited for the test period were unregulated or had regulators that were manually jacked wide open by the operators.

### Account for Artificial Demand of Unregulated Uses

We missed a couple of other usages that are important to measure to determine how the system will react. We have listed all of the categories and net volumes of usage to total the 1000 scfm. One of these categories we missed is artificial demand. This is added volume that the demand uses that is created by operating in the system with either unregulated usage or with no regulators at higher pressure than is actually required and no demand expander or master systems density control devices in the system. In a study we did for the American Council for an Energy Efficient Economy some years ago, we determined that in most cases, 80% of all usage in the 27 systems we audited for the test period were unregulated or had regulators that were manually jacked wide open by the operators.

Next, we consider that the supply is at 110 psig and the maximum required use pressure is 100 psig @ 70 °F. Assuming that the total air volume being consumed is 1000 scfm @ 110 psig @ 70 °F, we would ratio the proposed demand control pressure @ .4824 lb/scf, or 80 psig @ 70 °F divided by the current supply weight of one scf of air @ 110 psig @ 70 °F @ .635 lbs/scf. You would get a ratio of .7597. Now multiply 80%, or the total percentage of open unregulated usage, by the total air usage, or .80 X 1000 = 800 scfm. We now know that the difference between the current 1000 scfm and the resulting volume at 80 psig @ 70 °F is the ratio of the weight of the gas at the two different densities @ 70 °F or  $(1 - .7597) \times (1000 - 800) = 186$  scfm = 148 scfm artificial demand.

You must account for the reduced artificial demand from the other categories, which are unregulated. Open drainage was determined during the no load test and deducted from the no load total @ 186 scfm @ 118 psig. This volume is not included in the artificial demand because it is located upstream of the proposed demand expander. The total leaks, which we tested in a no load test, were @  $243 \times .7597 = 185$  scfm at 80 psig. Open blowing is 200 scfm X .7597 = 152 scfm @ 80 psig. The balance of the usage is an application which consumes 56.5 scf once every 30 seconds for a duration of 30 seconds at a rate of flow of 113 scfm. The balance of all usage is 200 scfm regulated @ <80 psig.

Let's look at Illustration #2 (on page 29), which shows us how the existing system's equipment profile is set up. We have a detailed look at the signal locations, set points on all of the compressors and differentials in the current supply system. By simply reducing demand by 25% and doing nothing else in supply besides shutting off the #5 compressor, you would reduce the power usage by 9.8% or 27 kWh. The pressure would continue to operate above 110 psig. This provides a poor return on investment.

**You can't buy  
the right compressor  
unless you have a  
CHOICE.**

*Gardner Denver: We assist, YOU choose.*



*Your compressed air requirements  
are as unique as your business.*

Only Gardner Denver has the complete product range to ensure your compressed air requirements are being satisfied with the ideal compressor equipment. Don't be told what to purchase by those who have one thing to sell.

Contact us for information about our complete line of compressed air solutions.

[GardnerDenverProducts.com](http://GardnerDenverProducts.com) • (800) 682-9868

**GD**  
**GARDNER DENVER**

*Experience Proven Results™*

## DEMAND VS. SUPPLY

### B. A 25% Demand Reduction Coupled with Automation

Let's assume that we take the same "low hanging fruit" approach to the demand side of the system and then decide to automate the compressors. If you install an "enabling" type of automation and change nothing in terms of the profile, the system will load four units and sit there operating at >111 psig.

Enabling systems do not control the compressors or their motors. They operate based on a pressure signal, and when it is too low, will activate the next compressor to do whatever that particular unit is set up to do. When the pressure transducer reads a preset higher value, it will provide a signal to disengage the last "on" unit.

Another approach towards automation is installing parallel pressure switches in a control panel and then spreading the switches across the existing settings on the compressor. If the units are in load/no-load, you can reduce some energy, but will also risk high power shut-downs, especially when the compressors are set up as high as these are. Remember, it is the sump pressure that

determines the amount of power used and you are starting off with the units operating 10% into the service factor of the motor. In both of the above examples, the system will still maintain four units on at all times with the demand the way it is.

One of the problems with load/no-load as an operating format is that as the pressure increases in this system, approximately 80% of the demand volume will increase — making it difficult (at best) to reach the unload pressure for a unit.

I was told by a wise man once that when you automate a problem, you wind up with an automated problem. If you want a proper solution to work, you must determine the right course of action and the correct order of those actions. In other words, you must come up with a detailed and cost-estimated action plan — including a new process flow diagram with a detailed constituents of demand profile and a new signals/differentials/set points profile. When I was 12-years old, my Dad told me "If you don't know where you are going, there are thousands of ways to get there." Auditing a system correctly is very demanding, yet also very rewarding.

### Part II

#### A. Let's Take a Proper Approach to the Problem and Solution

Let's go back to the process flow diagram and see what should be done to maximize the opportunity. We must first control the density of demand air usage @ <80 psig for all users, and eliminate artificial demand. We would accomplish this by installing an expander or isentropic regulating device at a central location downstream of the clean-up equipment and upstream of the demand piping distribution.

We obviously had to determine not only the constituents of demand, but also the highest pressures for each category of demand. Generally speaking, 80 psig is a good starting point at which to look at demand requirements. If you have a much higher pressure required for a particular application, you can choose to consider the alternatives to providing a dedicated compressor for the application or getting the required test equipment and testing to determine why such a high pressure is required. For more information on this, please refer to my article,

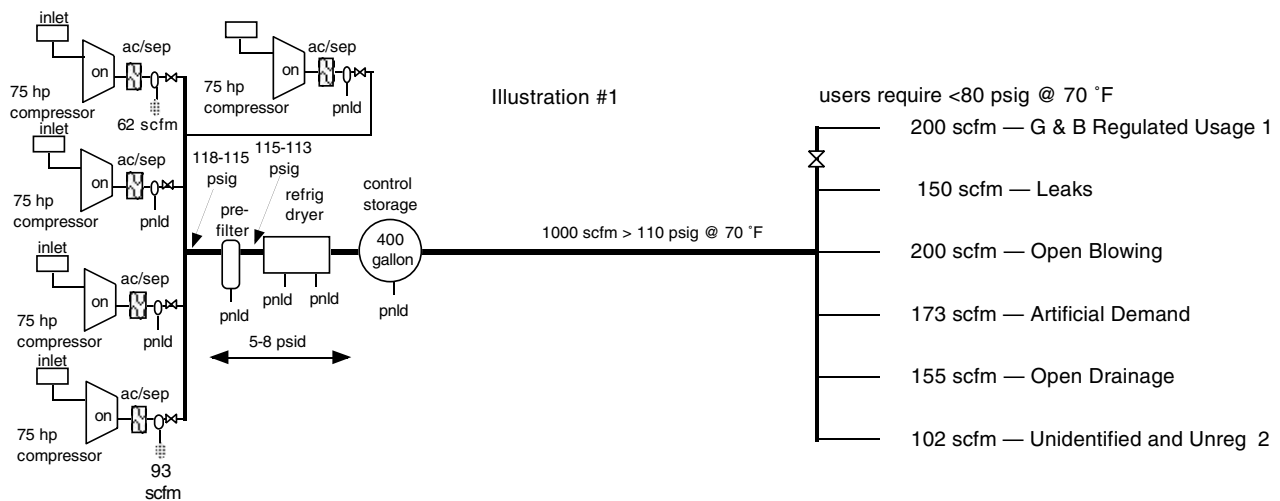

1 This category includes good and bad applications, although the bad apps do not warrant our attention or provide adequate ROI's.  
2 This app warrants our attention. It is a cyclical user: 102 scfm for 30 sec on and 30 sec off. The artical pressure required is 50 psig.

Illustration #1: The Existing Installation

“Pneumatics: Sizing Demand Users” in the October 2010 edition of *Compressed Air Best Practices® Magazine*.

Although this may seem simplistic, you can install an expander rated for a higher pressure and volume and then gradually reduce the system’s psig at 1 psig, per period of time, until someone in the plant complains about pressure. You then go to the application with your test gear, and determine why you need this higher pressure and correct the problem for a P4 initial pressure of 80 psig. You would then return to dropping the expander output value until you achieve your desired system pressure. This particular exercise requires discipline and cooperation on the part of production. This is the predominant reason for having production management involved in the audit from the first day.

It turns out that in this system, the last unidentified application rated @ 113 scfm @ 110 psig is the system’s culprit. In the past, whenever the system’s pressure dropped below

100 psig, this application would drop below the required article pressure and someone would demand a higher system pressure. This is, in fact, why a fifth compressor was added and why the system’s P3 pressure was jacked up to 110 psig. They must have thought that if 100 psig was safe, then 110 psig would be much safer. Let’s look at the proposed process flow diagram Illustration #3 (on page 30).

**B. Required Demand Changes**

Let’s first get the demand volume under control. It is common knowledge that leaks have an 80/20 rule. In most systems, 80% of the leak volume is represented in 20% of the leaks by count. What you should do is identify the leaks by volume using an ultrasonic leak detector. Generally, 20–25% of the largest leaks will easily reduce 80% of the leak volume. We have also installed a flow meter in the main header immediately downstream of the expander. This not only allows us to monitor flow for leak benchmarking, but also enables us to benchmark total systems flow.

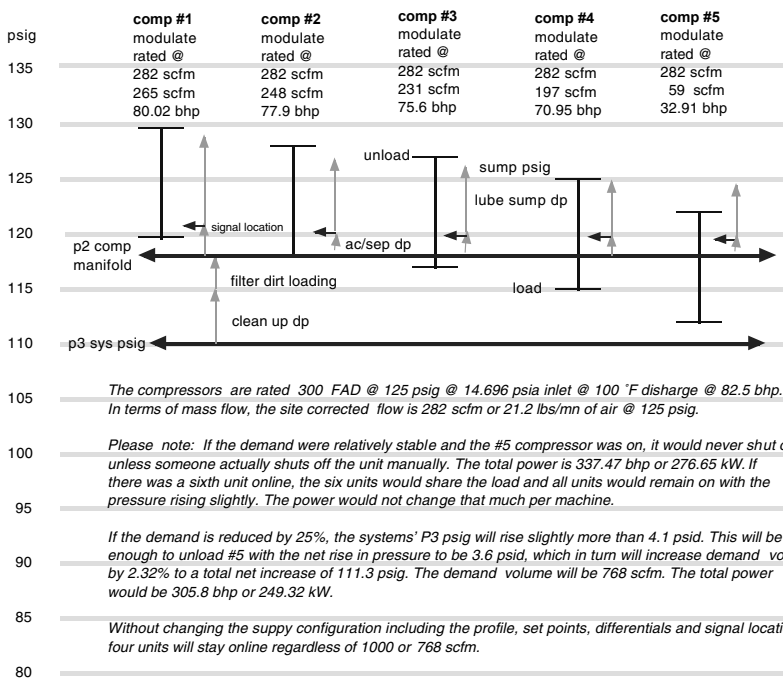

Illustration #2: A 25% Demand Reduction Only Equated to a 10% Power Reduction



**Intelligent  
VSD  
Technology**

GS SERIES  
20-50 HP/15-37KW  
Variable Speed  
Rotary Screw Compressor



- energy Saving
- exceptionally Quiet
- environmentally Smart



**Genuine. FS-Curtis.**

LEGENDARY CHOICE.

CURTIS-TOLEDO, INC.  
1905 Kienlen Avenue  
St. Louis, Missouri 63133  
800.925.5431

www.fscurtis.com

# DEMAND VS. SUPPLY

Proposed Process Flow Diagram

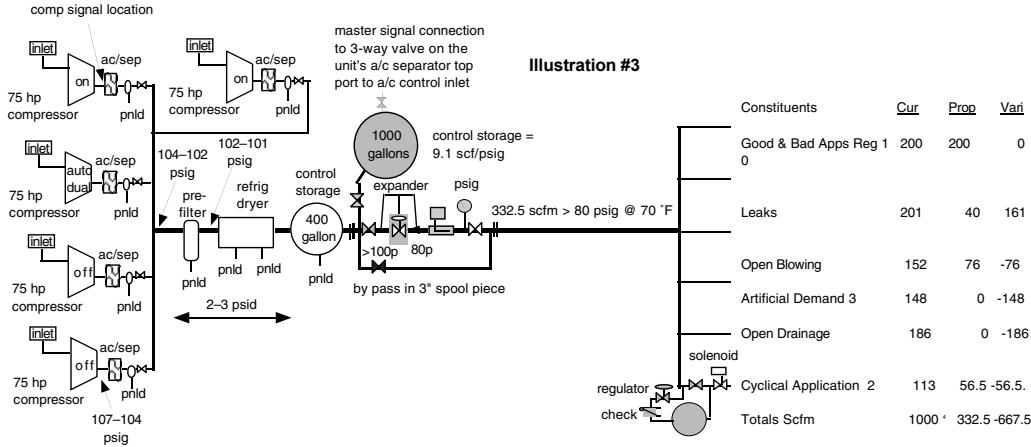

NB: Users, with the exception of the cyclical user category, require < 80 initial psig @ 70 °F @ the inlet at P5. When the pressure is measured at the inlet the starting pressure is the initial psig and the terminating pressure is the article pressure.

- 1 This category includes good and bad applications and is regulated at or below 80 psig. Bad apps do not warrant action because of weak ROIs.
- 2 This app warrants our attention because it is cyclical with at least 1/2 of the time off. It is 30 sec on and 30 sec off with a rate of flow of 113 scfm.
- 3 Artificial demand represents all of the unregulated air users, including all categories except G&B which is regulated. This includes all apps with regs which are either left wide open or have been tampered with by the operators. It represents the volume generated for operating above the proposed operating pressure, or in this case 80 verses 110 psig.
- 4 The total air usage is 1000 scfm, which we determined by either profiling the demand or directed measurement.

Illustration #3: Demand Reduction Coupled With Automation

It is also much more friendlier to specify a flow meter, which will be applied to a constant density flow.

The open blowing application is our next group to attack. You can use specialty nozzles, transvectors, ejectors or low-pressure blowers to replace open blowing applications. A 50% reduction is a no-brainer. **Please note:** The higher-velocity, lower-mass nozzles cannot be applied in the same manner as the high-mass, low-velocity open-blowing nozzles. Generally, they are applied a little further away and at a tangent to the surface you are blowing — as opposed to perpendicular to the surface being blown.

The open drainage is from aftercooler separator drain traps, stuck in the open position. The drain traps need to be repaired or replaced and put back into service. We would suggest pneumatic no-air-loss drains (PNLDs). Open drainage is identified as an unregulated, cyclical application. If the off time is equal to or more than the on time, there is an excellent opportunity to reduce demand.

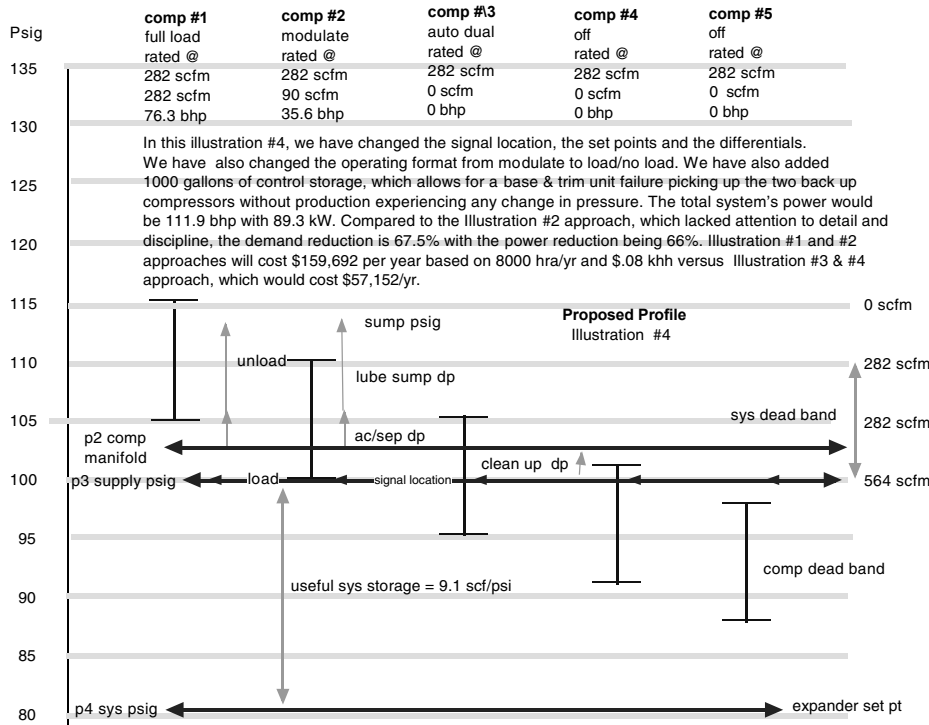

Illustration #4: Open Drainage and Storage

In this case, the application requires a rate of flow of 113 scfm for 30 seconds every minute. That indicates that the actual requirement is 30/60 X the rate-of-flow of 130 scfm = 56.5 scf per minute. Please see Illustration #3 (on this page) to follow along with the application description. At a rate-of-flow of 56.5 scfm (one half

of the current rate-of-flow), we can store 28.75 scf in a vessel in the 30 seconds that the application is off.

During the on time, we would continue to flow the other half of the 28.75 scf of air plus the stored volume to satisfy the application. The tank is sized for 28.75 scf in a delta pressure of 80 psig — the required article pressure of 50 psig = 30 psid. To determine the tank size, you must multiply the storage volume times 7.48 gallons/scf times the atmospheric pressure (14.696 psia) divided by the useful differential, or 30 psid in this case. The tank size would be >105 gallons, or a standard tank size of 120 gallons rated at 100 psig. Because the tank is 120/105 gallons larger than the 105 gallons or 43 scf of storage, at best this makes it difficult to control the application. A simpler approach is to regulate the in flow to a 105/120 X 30 psid = 26.5 psid + 50 psig article pressure, or 76.5 psig initial input pressure to the 120 gallon tank. The net results will be a much lower application pressure and a reduction of rate-of-flow of 50%. After all demand-side actions, including fixing the two drain traps on the supply side, the demand requirement has dropped to 369.5 scfm @ 80 psig @ 70 °F. Please take a look at Illustration #4 (on page 30) to see the proposed system's profile.

### C. Required Supply Changes

By changing the signal location to control storage, changing the set points on the compressors, changing the operation of the compressors to load/no-load and increasing control storage to handle the failure of an online compressor (without the supply psig running into the demand controller), **we can easily operate the supply system with 1.33 compressors.** The 67% reduction in demand volume will have an appreciable effect on the differential pressure of the air treatment equipment. Depending on the control storage

sizing, we could get the supply pressure down appreciably. That will increase the motor efficiency, reduce the stress on the motors and through proper equipment rotation allow for a more reliable and more cost-effective system with less than half of the maintenance cost. The cost of the system, when using the more disciplined approach, will reduce the total cost by \$102,540 — compared to \$11,977 with the more effortless approach.

Perhaps the greatest benefit to all concerned is the fact that you will have a statistically accurate demand system 100% of the time providing excellent quality control and repeatability for production. **BP**

*In the upcoming articles, we will discuss such subjects as rate of flow, rate of change, measurement, sizing demand at the point-of-use equipment and flat-lining high rate of flow and change applications using storage of potential energy to reduce the system's supply pressure, improve the energy used as well as control the quality of the application.*

*Mr. Foss has been auditing compressed air systems since 1969. He has written two books on the subject of compressed air systems, published more than 75 articles and conducted more than 650 one-to-three day seminars. He has audited more than 1,700 complete systems — generally medium to larger systems — and cross audited >2,500 added systems.*

*For more information, contact Mr. Foss at Air's a Gas Inc, 3728 Berrenstain Drive, St. Augustine, FL, 32092, [airsagas@aol.com](mailto:airsagas@aol.com) or at Tel: 904-940-6940 office, 904-826-7222 cell.*

# COMPRESSOR

Air-to-air and air-to-oil Coolers for  
Air Compressor Applications

# SERIES

NEW Series!

- UPA
- AA
- Belt Guard
- AHP/AHPH
- AOL
- ACOC/ACOCH
- AB
- C & SSC





**Thermal Transfer Products**  
A ThermoSys® Company

We COOL what you POWER

5215 21st Street Racine, Wisconsin 53406-5096 (262) 554-8330  
[TTPSales@thermasys.com](mailto:TTPSales@thermasys.com) [thermaltransfer.com](http://thermaltransfer.com)



REAL-  
WORLD...

## \$mart Sequencer® Controls

BY ROD SMITH,  
COMPRESSED AIR  
BEST PRACTICES®

Compressed Air Best Practices® Magazine interviewed Mr. Niff Ambrosino (Chief Operating Officer), Mr. Ernie Wichert (Systems Engineer) and Mr. Jeff Walker (Systems Engineer) from the Energy Services Division of Scales Industrial Technologies.

### Good Morning. Please Describe the \$mart Sequencer®.

Good morning. The \$mart Sequencer® is an air compressor control system designed to reduce a plant's energy costs by continuously monitoring system demand and automatically selecting the most energy efficient combination of available air compressors.

The \$mart Sequencer® was launched by our firm in 2001 after years of conducting system assessments and using vendor-supplied compressor control systems. Our founder, Bill Scales, is the representative for all compressed air consultants to the United States Department of Energy's Compressed Air Challenge®. In addition, five of our sales engineers are instructors for the Compressed Air Challenge® — the most of any organization in the nation. We drew upon this expertise when designing the \$mart Sequencer®.

### Why Is Measuring Flow Important to Measure Demand?

Over the many years we have conducted system assessments all over the world, one thing has always held true — compressed air systems

**always change.** This is why we designed the \$mart Sequencer®, to use multiple flow measurements, along with pressure readings, to establish the demand profile.

In order to measure demand, flow meters must be placed in the header(s) feeding the plant with compressed air. We recommend thermal mass-type flow meters — one for each header leaving each compressor room.

The \$mart Sequencer® is designed to take the actual flow and pressure measurements from multiple compressor rooms up to one and a half miles apart, to establish a true demand profile in a real world operating environment.

### What Is Wrong with Using Pressure to Calculate Flow?

There is nothing wrong with it — in a perfect world where nothing changes. Using pressure to back into your demand number (air flow) is a common practice after a system assessment has been done. Flow measurements are often taken during the system assessment and the solution will involve flow control valves, storage tanks and many other appropriate recommendations — which will be effective. Flow is calculated based upon the rate of change of pressure in a fixed volume (like a storage tank) and a demand profile is reached. Base-load air compressors are identified and trim-load compressors are sized up. A control system is installed to make the system



function optimally — all based upon the demand profile calculations done at the point-in-time of the system assessment.

What we have found with our many long-standing accounts is that over a period of time, the system will have changed and the compressor control system is no longer effective. In many cases, they become sized incorrectly and ineffective over time, as the demand changes.

The \$mart Sequencer® has the ability to use actual flow to guide its decisions and air compressor selections makes it a compressor control system that adapts to changes in a compressed air system over time.

### Does the \$mart Sequencer® Work with Any Type of Air Compressor?

Absolutely. What is really unique about the \$mart Sequencer® is not so much how we measure demand, but what the system controller can

do with this information as well as its ability to leverage the strengths of the onboard control systems of every type and brand of air compressor.

First and foremost, the \$mart Sequencer® does not make every machine an online/offline machine, which is a common shortcoming of control systems supplied by air compressor manufacturers. The \$mart Sequencer® makes efficient use of every installed machine's capabilities.

Some air compressors, for example, use displacement control and are most efficient between 40–100% of full-load capacity. The \$mart Sequencer® will employ the variable displacement capacity control as part of an overall control scheme. Other control systems typically operate them as online/offline machines — at lower efficiencies.

### So the \$mart Sequencer® Tries to Leverage the Strength of each Air Compressor?

Correct. The \$mart Sequencer® makes full use of modulation, variable displacement, on-line/off-line and/or variable speed drives capacity controls. It has the capability to modulate multiple compressors, regardless of the manufacturer, simultaneously, when this results in the lowest power usage. This also allows the compressors to operate at the minimum pressure required by the plant. Storage-based systems require that the trim compressors operate at elevated pressures, which increases the power required.

“Cascading” controls, for example, will set out “pressure bands”, which determine which air compressor will turn on/off in a sequential order. This can work well in a new installation with four new air compressors from the

## Dewpoint Measurement in Compressed Air

Vaisala DRYCAP® dewpoint instruments have been developed for the most demanding conditions

- Fastest wet-to-dry response time on the market - just minutes
- High resistance to contamination - immune to compressor oil
- Complete recovery from saturated conditions
- Long 2 year calibration interval

Download the **FREE** technical article "Increase Compressor Plant Efficiency with Dewpoint Demand Switching" at [www.vaisala.com/dewpoint\\_demand](http://www.vaisala.com/dewpoint_demand)



## REAL-WORLD \$MART SEQUENCER® CONTROLS

same manufacturer. The \$mart Sequencer® automatically selects the correctly sized compressors for a given demand. It does not operate the compressors in a fixed sequence. For example, if the system demand increases by 500 cfm, the \$mart Sequencer® will automatically start the smallest compressor available that will provide the additional 500 cfm. Using the same example, the \$mart Sequencer® may add a 1,500 cfm compressor (if a 500 cfm compressor is not available) while turning off a 1,000 cfm unit.

After years of system assessments, we found that we were often dealing with six different air compressor sizes — from three different manufacturers — using four different compression and control technologies! A simple “sequencer” was inadequate.

The \$mart Sequencer® was therefore designed to be pre-programmed, before each job, to understand the strengths and efficiencies of the individual installed air compressors. This allows it to choose which air compressors should be running and which should be off — always based strictly upon selecting the most energy efficient way to satisfy the plant’s compressed air demand requirements.

Installations with centrifugal air compressors, for example, are great for the \$mart Sequencer®.

Centrifugal air compressors use inlet guide vanes (or butterfly valves) to maximize their efficiencies at partial loads. The \$mart Sequencer® leverages this, and continues to run the same air compressor down along the “sweet spot” of the curve of the guide vanes. The \$mart Sequencer is capable of “turning down” multiple centrifugal compressors simultaneously.

Although storage may be appropriate in compressed air systems, it is just not a substitute for proper compressor control. In cases where there are large spikes in demand or where a reserve supply of compressed air is required, additional storage may be part of the solution. In these cases, the \$mart Sequencer® has the ability to fully benefit from storage without the need of operating the compressors continuously at a higher pressure.

### What Type of Software Is Used?

It uses commercially available software from Allen Bradley. The end user receives a copy of the program, as well. As mechanics, we have noticed that customers like this because it provides them with a clean copy both for reference and as a back up, so if something isn’t working right, the program is there.

The \$mart Sequencer® connects to any manufacturer’s compressor control panel,

with which the operators are already familiar. Each panel will have the ability to switch between remote and local, which allows any compressor to be removed from the system for maintenance, etc. The \$mart Sequencer® will automatically compensate, provided, of course, that there is adequate excess compressor capacity available.

### Are There Any Remote Monitoring Capabilities?

Remote monitoring is possible with the system, as is trouble-shooting and remote control. The customer can monitor in real time the current, average and peak flows in scfm — and it’s a real number. We also monitor the actual and average kW to produce that flow. We provide a straightforward scfm/kW metric. No calculations — just real data. A trend screen for all data is included.

This scfm/kW data now provides the customer with real-time metrics they can manage. How much air is produced and how much power was required to produce it? This is when improvements begin.

### Thank you for your insights. BP

For more information, please contact Jeff Walker, Scales Energy Services Division, Scales Industrial Technologies at Tel: 610-955-9688 or email: [jwalker@scalesair.com](mailto:jwalker@scalesair.com), [www.ScalesIndTech.com](http://www.ScalesIndTech.com).



The \$mart Sequencer® Main Menu button on the status screen provides real-time scfm/kW metrics to analyze the efficiency of the compressed air system

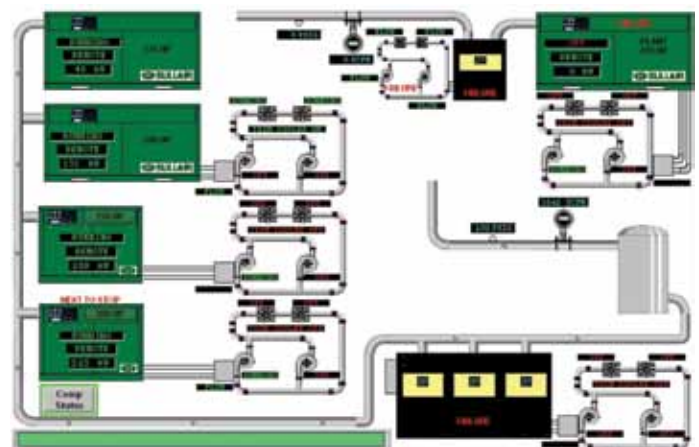

The \$mart Sequencer® displays graphics representing the entire compressed air system as a whole. It includes each compressor and its operational status, as well as system flow, pressure and power



# ENERGY INCENTIVES

## PG&E's Third-Party Energy Incentive Programs

BY COMPRESSED AIR BEST PRACTICES®



® Compressed Air Best Practices® Magazine interviewed Mr. Justin Kjeldsen, Mr. Jeff Kohn and Mr. Sam Zimmerman, senior program managers for Pacific Gas and Electric Company (PG&E).

### Please Describe PG&E's Third-Party Energy Incentive Programs.

PG&E runs energy incentive programs through two channels. We have our core channel representing the majority of our energy incentive offerings, and we offer energy incentives through third-party channels. Our third-party programs account for approximately 20% of the energy incentive dollars. PG&E has contracted with 34 third-party companies, or implementers, to run 50 contracts. We are part of a team of 12 program managers managing these contracts and the implementers that run them.

Several of our contracts focus on compressed air. We have programs that focus on industrial customers, and we have a program that focuses on agricultural and food customers. The incentive programs take the whole compressed air system into account. We see projects ranging from air compressor retrofits, air storage and distribution, dryers and demand-side projects, including nozzles to reduce open blows. The implementers work with the customers to identify areas where cost-effective energy efficiency can be achieved.



The incentive programs take the whole compressed air system into account. We see projects ranging from air compressor retrofits, air storage and distribution, dryers and demand-side projects, including nozzles to reduce open blows.



Don't let the rotary screw boys throw you a "curve" when it comes to saving energy.

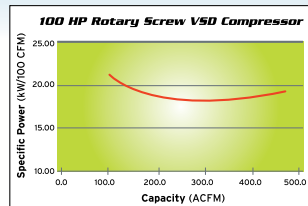

- OPTIMA Series VSD air compressors deliver superior energy savings across varying levels of air demand.
- MAXIMA Series deliver more air more efficiently for superior base-load/high volume air production.

Combined, they offer the most energy efficient system money can buy to slash your energy costs.

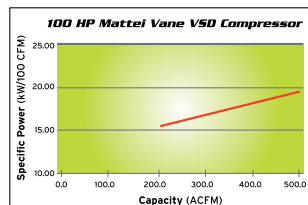

**MATTEI. Precise. Efficient. Silent.**

[www.matteicomp.com](http://www.matteicomp.com)

Experience The Revolution. Get A MATTEI.



# ENERGY INCENTIVES

## PG&E's Third-Party Energy Incentive Programs

### Why Does PG&E Have Third-Party Incentive Channels?

With the third-party programs, we get a more focused, innovative approach. We hire experts with specialized skills uniquely qualified to meet the needs of the customers we serve. The objective is to identify innovative design in the energy incentive programs we manage and access hard-to-reach market segments not being well served by our core incentive programs. The third-party programs expand PG&E's reach and customer awareness of our incentive programs. In order to go to the next level of energy efficiency, certain market segments (especially industrial customers) require a truly customized and tailored energy incentive program.

Our contracts with third-parties pay experts to provide technical expertise and deliver completed projects that save energy. The implementers typically work on a "pay for performance" basis, which means we pay them a contracted performance rate for actual energy saved only when projects are completed and verified.

### What Energy Incentives Are Offered?

With all of these programs, PG&E pays for 100% of the audit cost. On projects, we pay an incentive of \$.09 per kWh and a \$100.00 kicker for peak kW reduction. We do not have a maximum dollar limit for a project, but we do cap the incentives at 50% of the total project costs. There are maximum dollar amounts for energy incentives per client, based upon total energy purchased.

### Please Describe the Third Party-Managed Programs for Industrial Compressed Air Systems.

We have two third-party programs specifically created for industrial customers with compressed air systems. The first program, called AIM (Assessment, Implementation and Monitoring), is for systems with more than 700 horsepower of installed air compressors. The second program, called Ecos Air, is for systems with less than 700 hp of installed air compressors

The AIM Program is operated by Air Power of Ohio. The Industrial Compressed Air Program is operated by Ecos Air. More on the food processing can be found in the graph below. These two specific air compressor programs were originally contracted in the 2006–2008 program cycle and continue on today.

### What Kind of Results Have You Experienced?

Both the AIM and Ecos programs have been successful at delivering energy savings. Between 2006 and the end of 2009, the AIM Program delivered 18.5 GWh and 2.3 MW in savings. During the same time, the Ecos Air Program saved 25.7 GWh and 3.3 MW. We feel that both programs are excellent complements to our other incentive programs and that we are reaching customers we would not otherwise reach.

The AIM Program Process

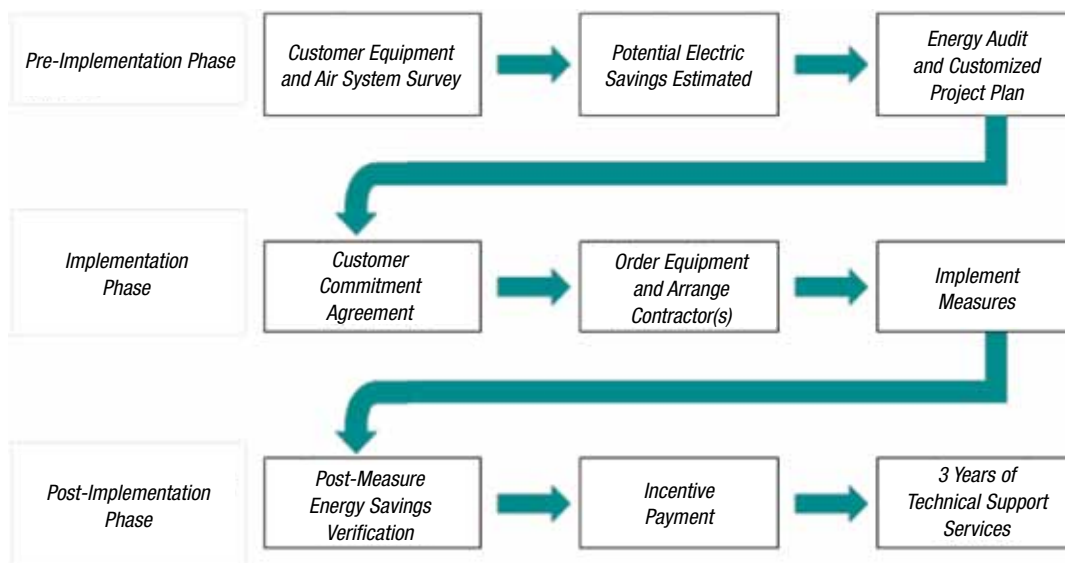

**Please Describe the Process.**

Awareness for the program comes from several methods. The PG&E account representatives have existing relationships with our customers and introduce the programs where there is a benefit. The implementers do their own program marketing, and they leverage existing relationships and corporate contacts. They also make all the local air compressor distributors aware of the programs. These distributors, in turn, inform their industrial clients of the benefits to making energy efficient upgrades to their compressed air systems.

We rely on the implementers (Air Power and Ecos Air) to operate the programs on our behalf. They develop the program materials and they take leads from our PG&E account representatives. We rely on them to work with the customer and to facilitate the project from audit to verification.

**Please Describe the Industry-Specific Food Processing Incentive Program.**

We have recently launched an incentive program, managed by Global Energy Partners, called the Comprehensive Food Processing Energy Efficiency Program, which targets all food processors, excluding wineries and dairies. We have designed energy efficiency incentives for most of the energy consuming processes found in a food plant. The most common measures that receive incentives under this program are:

- Industrial refrigeration
- Space conditioning
- Heat recovery
- Process optimization
- Control optimization
- Steam process optimization
- Compressed air systems
- Water conservation and water treatment

The incentive rates are \$0.05/kWh saved for all lighting measures, \$0.15/kWh saved for major HVAC and refrigeration measures, \$0.09/kWh for all other electricity savings and \$1.00/therm saved for all gas measures. Additionally, we pay \$100/peak kW saved.

**Thank you for your insights. BP**

For more information on PG&E's third-party energy incentive programs, please contact:

- *Assessment, Implementation and Monitoring Program — EJ Honton, Air Power USA, ej@airpowerusainc.com, Tel: 415-845-1076*
- *Industrial Compressed Air Program — Rupert Dallas, Ecos Air, rdallas@ecosconsulting.com, Tel: 503-525-2700 x160*
- *Comprehensive Food Processing Audit and Resource Efficiency Program — Mark Reedy, Global Energy Partners, mreedy@geplc.com, Tel: 925-482-2006*



**PG&E runs energy incentive programs through two channels. We have our core channel representing the majority of our energy incentive offerings, and we offer energy incentives through third-party channels.**

**airleader** Compressor Management  
efficient - transparent - effective

**AIRLEADER Professional Master Control and Monitoring**

- Real-time demand based and self-learning
- Web accessible monitoring and alerting
- Ongoing system efficiency benchmarking
- Continuous data logging and trending
- Verifies savings, detailed and precise
- Unrivalled price performance, short payback time





info@airleader.us  
www.airleader.us  
Phone: (616) 828 0716

**More than 6,000 satisfied customers already saved millions! When do you start?**

# COMPRESSED AIR CONTROLS

EXCERPTED AND SUBMITTED BY  
RON MARSHALL AND BILL SCALES FOR  
THE COMPRESSED AIR CHALLENGE®



Compressed air system controls match the compressed air supply with system demand and are one of the most important determinants of overall system energy efficiency. This article, an excerpt of a Compressed Air Challenge® **Fact Sheet #6**, which is part of the CAC® publication **“Improving Compressed Air System Performance, A Sourcebook for Industry”**, discusses both individual compressor control and overall system control of plants with multiple compressors. Proper control is essential to efficient system operation and high performance. “While there are other actions that impact energy usage to produce compressed air, a properly applied and operating compressor capacity control system is the only way to translate less compressed air used into lower input electrical power and energy consumption,” advises Hank Van Ormer of Air Power USA, Inc, a senior compressed air auditor and an Advanced Level CAC® instructor. The objective of any control strategy is also to shut off unneeded compressors or delay bringing on additional compressors until needed. All units that are operating should be run at full-load, except one unit for trimming.

Compressor systems are typically comprised of multiple compressors delivering air to a common plant air header. The combined capacity of these machines is generally sized to meet the maximum plant air demand. System controls are almost always needed to orchestrate a reduction in the output of the individual compressor(s) during times of lower demand. Compressed air systems are usually designed to operate within a fixed pressure range and to deliver a volume of air that varies with system demand. System pressure is monitored and the control system decreases compressor output when the pressure reaches a predetermined level. Compressor output is then increased again when the pressure drops to a lower predetermined level.

The difference between these two pressure levels is called the control range. Depending on air system demand, the control range can be anywhere from 2–20 psi. In the past, individual compressor controls and non-supervised multiple machine systems were slow and imprecise. This resulted in wide control ranges and large pressure swings. As a result of these large swings, individual compressor pressure control set points were

established to maintain pressures higher than needed. This ensured that swings would not go below the minimum requirements for the system. Today, faster and more accurate microprocessor-based system controls and variable speed compressors with tighter control ranges allow for lower system pressure set points. Precise control systems are able to maintain lower average pressure without going below minimum system requirements.

A rule of thumb for systems in the 100 psig range is for every 2 psi increase in discharge pressure, energy consumption will increase by approximately 1% at full output flow (check performance curves for centrifugal and two-stage lubricant injected rotary screw compressors). There is also another penalty for higher-than-needed pressure. Raising the compressor discharge pressure increases the demand of every unregulated usage, including leaks, open blowing, etc. Although it varies by plant, unregulated usage is commonly as high as 30–50% of air demand. For systems in the 100 psig range with 30–50% unregulated usage, a 2 psi increase in header pressure will increase energy consumption by about another 0.6–1.0%, because of the additional unregulated air being consumed.

### Fundamentals of Compressed Air Systems WE (web-edition)



The Compressed Air Challenge® (CAC®) is pleased to announce the Winter 2010 session of *Fundamentals of Compressed Air Systems WE* (web-edition) is coming November 23rd. Led by our experienced instructors, this web-based version of the popular *Fundamentals of Compressed Air Systems* training uses an interactive format that enables the instructor to diagram examples, give pop quizzes and answer students' questions in real time. Participation is limited to 25 students. Please visit [www.compressedairchallenge.org](http://www.compressedairchallenge.org), to access online registration and for more information about the training.

If you have additional questions about the new web-based training or other CAC® training opportunities, please contact the CAC® at [info@compressedairchallenge.org](mailto:info@compressedairchallenge.org).

The combined effect results in a total increase in energy consumption of about 1.6–2% for every 2 psi increase in discharge pressure for a system in the 100 psig range with 30–50% unregulated usage.

Caution needs to be taken when lowering average system header pressure because large, sudden changes in demand can cause the pressure to drop below minimum requirements, which can lead to improper functioning of equipment. With careful matching of system controls and storage capacity, these problems can be avoided.

### Controls and System Performance

Few air systems operate at full-load all of the time. Part-load performance is therefore critical, and is primarily influenced by compressor type and control strategy. The type of control specified for a given system is largely determined by the type of compressor being used and the facility's demand profile. If a system has a single compressor with a very steady demand, a simple compressor control system may be adequate. On the other hand, a complex system with multiple compressors, varying demand and many types of end-uses will require a more sophisticated strategy. In any

case, careful consideration should be given to both compressor and system control selection because they can be the most important factors affecting system performance and efficiency.

### Individual Compressor Control Strategies

Over the years, compressor manufacturers have developed a number of different types of control strategies. Controls such as start/stop and load/unload respond to reductions in air demand, increasing compressor discharge pressure by turning the compressor off or unloading it so that it does not deliver air for periods of time. Modulating inlet and multi-step controls allow the compressor to operate at part-load and deliver a reduced amount of air during periods of reduced demand.

**Start/Stop.** Start/stop is the simplest control available and can be applied to either reciprocating or rotary screw compressors. The motor driving the compressor is turned on or off in response to the discharge pressure of the machine. Typically, a simple pressure switch provides the motor start/stop signal. This type of control should not be used in an application that has frequent cycling because repeated starts will cause the motor to overheat and other compressor components to require

more frequent maintenance. This control scheme is typically only used for applications with very low duty cycles for compressors in the 25 horsepower and under range. Its advantage is that power is used only while the compressor is running, but this is offset by having to compress to a higher receiver pressure to allow air to be drawn from the receiver while the compressor is stopped.

**Load/Unload.** Load/unload control, also known as constant speed control, allows the motor to run continuously, but unloads the compressor when the discharge pressure is adequate. Compressor manufacturers use different strategies for unloading a compressor, but in most cases, an unloaded rotary screw compressor will consume 15–35% of full-load horsepower while delivering no useful work. As a result, some load/unload control schemes can be inefficient.

**Modulating Controls.** Modulating (throttling) inlet control allows the output of a compressor to be varied to meet flow requirements. Throttling is usually accomplished by closing the inlet valve, thereby restricting inlet air to the compressor. This control scheme is applied to centrifugal and lubricant-injected rotary screw

## COMPRESSED AIR CONTROLS

### CAC Qualified Instructor Profile

#### Hank Van Ormer

Air Power USA, Inc.  
11520 Woodbridge Lane  
Baltimore, OH 43105  
Phone: (740) 862-4112  
Fax: (740) 862-4112  
hankvanormer@aol.com



Mr. Van Ormer has been associated with the compressed air business for over forty years.

He has visited more than 5,000 facilities and audited hundreds of compressed air systems throughout the world. Clients include Boeing, Ford Motor, General Motors, John Deere, and other Fortune 500 corporations.

In 1986, Mr. Van Ormer formed his independent consulting company, Air Power USA, Inc, specializing in compressed air systems. He has developed several accredited training courses for continuing education and complete curriculum for technical colleges. The instructor featured here is available to lead a **Compressed Air Challenge seminar** at your facility. Visit [www.compressedairchallenge.org](http://www.compressedairchallenge.org) for more information.

compressors. This control method cannot be used on reciprocating or lubricant-free rotary screw compressors, and when applied to lubricant-injected rotary screw compressors, is an inefficient means of varying compressor output. When used on centrifugal compressors, more efficient results are obtained, particularly with the use of inlet guide vanes which direct the air in the same direction as the impeller rotation. However, the amount of capacity reduction is limited by the potential for surge and minimum throttling capacity.

Inlet valve modulation used on lubricant-injected rotary air compressors allows compressor capacity to be adjusted to match demand. A regulating valve senses system or discharge pressure over a prescribed range (usually about 10 psi) and sends a proportional pressure to operate the inlet valve. Closing (or throttling) the inlet valve causes a pressure drop across it, reducing the inlet pressure at the compressor and, hence, the mass flow of air. Since the pressure at the compressor inlet is reduced while discharge pressure is rising slightly, the compression ratios are increased so that energy savings are somewhat limited. Inlet valve modulation normally is limited to the range from 100% to about 40% of rated capacity, at which point the discharge pressure will have reached full load pressure plus 10 psi and it is assumed that demand is insufficient to require continued air discharge to the system. At this point, the compressor can fully unload as previously described in a compressor using load/unload control.

**Dual Control/Auto Dual.** For small reciprocating compressors, dual control allows the selection of either start/stop or load/unload. For lubricant-injected rotary screw compressors, auto dual control

provides modulation to a pre-set reduced capacity followed by unloading with the addition of an over-run timer to stop the compressor after running unloaded for a pre-set time.

**Variable Displacement.** Some compressors are designed to operate in two or more partially-loaded conditions. With such a control scheme, output pressure can be closely controlled without requiring the compressor to start/stop or load/unload.

Reciprocating compressors are designed as two-step (start/stop or load/unload), three-step (0%, 50%, 100%) or five-step (0%, 25%, 50%, 75%, 100 %) control. These control schemes generally exhibit an almost direct relationship between motor power consumption and loaded capacity.

Some lubricant-injected rotary screw compressors can vary their compression volumes (ratio) using sliding or turn valves. These are generally applied in conjunction with modulating inlet valves to provide more accurate pressure control with improved part-load efficiency.

**Variable Speed Drives.** Variable speed is accepted as an efficient means of rotary compressor capacity control, using integrated variable frequency AC or switched reluctance DC drives. Compressor discharge pressure can be held to within +/-1 psi over a wide range of capacity, allowing additional system energy savings.

Rotary screw compressors with fixed-speed drives can only be stopped and started a certain number of times within a given time frame. Depending on the control scheme used, instead of stopping the compressor, it will be unloaded, throttled or the compressor displacement will be varied in applications where the demand for air changes over time. In some cases, these



# TECHNOLOGY DRIVES INNOVATIONS WITH PRESSURE. BE A PART OF IT.



**ComVac** is the leading international trade show for energy efficient and sustainable solutions in the area of compressed air and vacuum technology. As the worldwide most important meeting place, the show provides you with the perfect platform to deepen industrial contacts and to globally position your company. Take advantage of our hosted opportunity to create awareness around your innovations: [hannovermesse.de/comvac\\_e](http://hannovermesse.de/comvac_e)



GET NEW TECHNOLOGY FIRST  
4-8 April 2011 · Hannover · Germany

## COMPRESSED AIR CONTROLS

control methodologies can be an inefficient way to vary compressor output. Compressors equipped with variable speed drive controls continuously adjust the drive motor speed to match variable demand requirements.

In a positive displacement rotary compressor, the displacement is directly proportional to the rotational speed of the input shaft of the air end. However, it is important to note that with constant discharge pressure, if efficiency remained constant over the speed range, the input torque requirement would remain constant, unlike the requirement of dynamic compressors, fans or pumps. The actual efficiency also may fall at lower speeds, requiring an increase in torque. Electric motors and controllers are currently available to satisfy these needs, but their efficiency and power factor at reduced speeds must be taken into consideration.

### Multiple Compressor Control

Systems with multiple compressors use more sophisticated controls to orchestrate compressor operation and air delivery to the system. Network controls use the on-board compressor controls' microprocessors linked together to form a chain of communication that makes decisions to stop/start, load/unload, modulate, vary displacement and vary speed. Usually, one compressor assumes the lead

role, with the others being subordinate to the commands from this compressor. System master controls coordinate all of the functions necessary to optimize compressed air as a utility. System master controls have many functional capabilities, including the ability to monitor and control all components in the system, as well as trending data to enhance maintenance functions and minimize costs of operation. Other system controllers, such as pressure/flow controllers, can also substantially improve the performance of some systems.

**Network Controls.** Network controls use the on-board compressor controls' microprocessors linked together to form a chain of communication that makes decisions to stop/start, load/unload, modulate, vary displacement and vary speed. Usually, one compressor assumes the lead role with the others being subordinate to the commands from this compressor.

Less sophisticated network controls use the cascade set point scheme to operate the system as a whole. Those systems are capable of avoiding part load compressors, but can still present the problem of approaching production's minimum pressure requirement as more and more compressors are added and the range of compressor load and unload set points increases.

The more sophisticated network control systems use single set point logic to make their operational decisions to start/stop, etc. In systems with positive displacement compressors (reciprocating, rotary screws, etc.), all compressors are kept fully loaded except for one compressor that is operated in some part load fashion specific to the design of the machine.

Three major disadvantages of network system controls are:

- They are capable of controlling only air compressors
- They cannot be networked with remote compressor rooms without a master control of some type
- Typically, they only work with compressors of the same brand and configuration because of microprocessor compatibility issues

Expensive upgrades or retrofits may need to be made to make different brands of compressors or older versions of the same brand work in the system. In some cases, retrofits are not available and different brand or outdated compressors cannot be used in the control scheme.

**Diagram 1: Cascading Set Point (Source: CAC® Best Practices for Compressed Air Systems)**

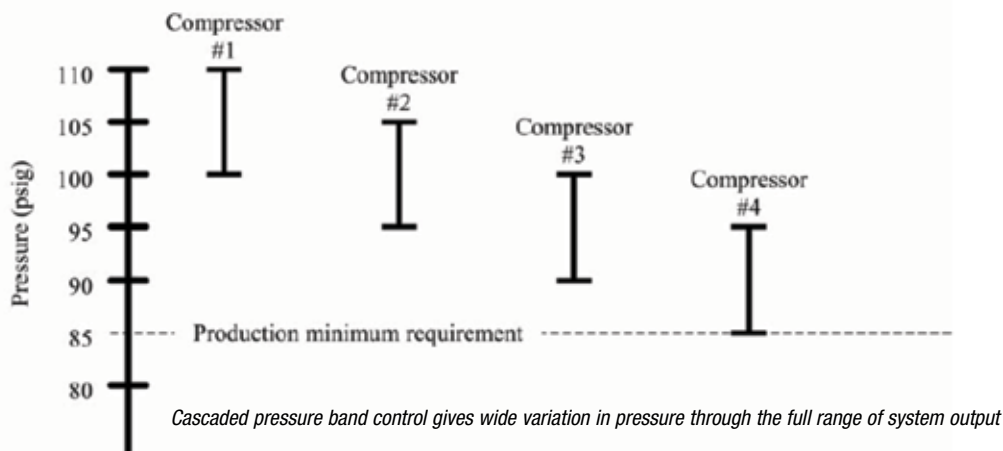

There are no network controls available that can coordinate the control of rotary screw, reciprocating and centrifugal compressors as one system. To do this, system master controls are required, especially if there is a desire to monitor and operate compressors, cooling systems, dryers, filters, traps, storage, pressure/flow controllers and any other part of a compressed air system that a facility might want included in the control scheme.

**System Master Controls.** If complexity outpaces the capabilities of local and network controls, a system master control is required to coordinate all of the functions necessary to optimize compressed air as a utility. System master controls have many functional capabilities, including the ability to monitor and control all components in the system, as well as trending data to enhance maintenance functions and minimize costs of operation. System master controls interface with all brands and types of air compressors, and can coordinate the operation of satellite compressor rooms spread around the facility, or in different buildings across an industrial campus. The primary function of these controls, as with the network controls, is to operate a multiple compressor system in harmony. “Pressure-actuated central capacity control systems are basically reactive in nature, meaning that regardless of a response time, no

action can be taken until after something has occurred,” says Van Ormer. “There is a trend in recently developed central air management systems of using system pressure combined with flow-based data to create more proactive systems,” he continues. “Combining many critical data inputs into the software analysis, such as unit load position, specific power and, particularly with mass flow compressors, ambient and inlet conditions, often allows a timely adjustment prior to the actual event optimizing the system even more. There are many action data inputs used. See article Compressed Air Management Systems in the October 2009 edition of *Compressed Air Best Practices*® Magazine.”

The least sophisticated have few, if any, of the features mentioned above, and use cascading set point logic to control compressors. The most sophisticated, state-of-the-art system master controls use single point control logic with rate of change dynamic analysis to make decisions regarding how the compressed air system responds to changes. These changes can occur on the demand side, supply side or in the ambient conditions — all affect the performance of the system and have a role in how the system should respond. Some of these require short duration support, such as additional storage.

### Multiple Compressor Control with VSD

Control of multiple compressors in a system that includes fixed speed and VSD compressors requires a special approach to avoid unintended system and control issues. This subject is beyond the scope of this article and planned for a future CAC® submission. If this situation applies to you, or if you are interested in applying a new VSD compressor to your system, we recommend reading a further discussion of multiple compressor controls that appears in the CAC® “**Best Practices for Compressed Air Systems**” Appendix 2.A.4 (This 325-page manual is available at the CAC® bookstore). To purchase your copy, go to our **Compressed Air Challenge**® website or visit [www.compressedairchallenge.org](http://www.compressedairchallenge.org) for more information. **BP**

**Diagram 2: Single Set Point Strategy (Source: CAC® Best Practices for Compressed Air Systems)**

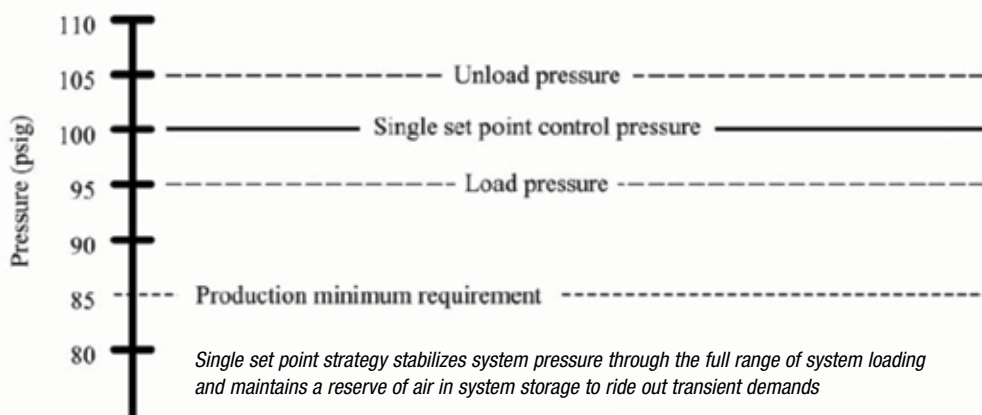

# The 2010 NAACD

# conference & exhibition



A CompAir L-Series AirStation 15 hp rotary screw and refrigerated dryer mounted on an 80-gallon storage tank. Pictured are Vinson Sill, Larry Olesky and Bryan Fasano (left to right)



A Hydrovane Duplex package with two 10 hp rotary vane compressors mounted on a storage tank. Pictured are Bill Steele, Kurt Barhorst and Dean Chew (left to right)



CompAir and Hydrovane launched a new air treatment program at the NAACD, including refrigerated and desiccant dryers and filtration products. Pictured is Jay Francis from SPX Flow Technology

The 2010 North American Association of Compressor Distributors (NAACD) Conference and Exhibition was held October 3–5 in Tucson, Arizona. A strong turnout of CompAir and Champion distributors and exhibitors enjoyed the beautiful desert scenery.

Since Gardner Denver's acquisition of CompAir at the end of 2008, the NAACD has forged a strong relationship with Gardner Denver (GD). According to the NAACD president, **Mr. Shaun Orr**, of Compressed Air Systems, Inc., "One of the more positive developments for the NAACD has been the creation of a very strong relationship with Gardner Denver."

### CompAir, Hydrovane and Champion Compressors

The anchor exhibitor and partner with the NAACD is Gardner Denver, the parent company of CompAir, Hydrovane and Champion products. The one thing that all NAACD members have in common is that they all represent CompAir, Hydrovane and Champion compressed air system products. Gardner Denver CEO, **Barry Pennypacker**, demonstrated GD's support of the NAACD by not only attending the conference, but by delivering the keynote speech. It's great to see the CEO of an almost \$2 billion company attend the NAACD and be that close to the "feet on the street." The two comments from the speech that jumped out at me were (1) 70% of Gardner Denver's global revenues today come from outside the U.S. (that's a huge accomplishment and CompAir is a big part of that!), and (2) Champion, Hydrovane and CompAir distributors are being encouraged to grow their market share, in the 5–15 horsepower segment, with rotary screw, piston and rotary vane technologies.

The CompAir, Hydrovane and Champion product line offering really covers all the bases. Director of sales and marketing, **Gary Gillespie**, had a broad range of technologies to show NAACD members: CompAir oil-free and lubricated rotary screws, Hydrovane rotary vanes and Champion oilless and tank-mounted reciprocating air compressors with magnetic starters.

The CompAir L Series rotary screw compressor is a favorite product of CompAir distributors. On display was a 50 hp regulated-speed L37RS unit with a 68 dba sound attenuation package. The product features an integrated airend operating at low rotational speeds with a small package footprint. The units come standard with high-efficiency TEFC motors and Wye/Delta starters. A "complete system package" was also on display, featuring a 15 hp rotary screw L11 unit and a refrigerated dryer, mounted on a 120-gallon storage tank.



## Exhibits

Exhibited were multiple brands of compressed air dryers, filters, intake air filters, compressor lubricants and condensate management products. The NAACD members do an outstanding job of visiting every booth and really getting to know the equipment vendor.

Natural gas is a growing industry these days, and it was interesting to learn of the continued growth of landfill/digester gas retrieval systems. **Jim Donohue**, from Pneumatech, explained that dry gas allows engines and boilers to perform trouble-free. Pneumatech refrigerated gas dryers can handle applications ranging from 100,000 CF/day to 21 million CF/day.

Parker Finite displayed their alternative fuel and high-pressure filtration products. These filters cover all natural gas filtration requirements — from the gas well to the dispenser. They also have a full range of stainless steel, steam, vacuum exhaust and gas-sampling filters. It's interesting to see how many filtration applications exist outside the standard compressed air system.

The growth of compressed air system assessments has been very positive for manufacturers of air storage tanks, such as SPVG (Steel Pressure Vessel Group) and Manchester Tank.

**Liane Callow** and **Mike Downey** of SPVG explained how orders for 3,000–30,000 gallon tanks are now a standard part of their business to support system assessments.

Summit Industrial Products reported continued growth in domestic sales with their line-up of synthetic air compressor lubricants, descalers and degreaser chemicals and oil/water separators. Ultrachem presented their food-grade and high-pressure compression lubricants.

BEKO continues to develop technologies to protect against oil carryover into compressed air systems. The BEKOKAT® system is capable of eliminating hydrocarbons from the compressed air stream using a special catalyst granulate. The company complements this product with the METPOINT® OCV range of hydrocarbon monitoring systems with analytic controls. Other instruments are offered making possible the measurement of compressed air dew point, flow and leaks.

## Conclusion

My apologies go to those exhibitors not mentioned here due to space considerations. I also have to apologize to the maintenance people I almost hit during the NAACD golf tournament. The Westin La Paloma golf course produced many roadrunners and “postcard settings”, and I thank my group of Tom Pischl (CompAir), John Haslam (Universal Air Products) and Sam Wimberly (RWI) for their company. The overall atmosphere of the NAACD Convention continued to be the same friendly and professional experience we have grown to expect. **BP**



*Jim Donohue (Pneumatech) and Janelle King (Hydra Flow West) reviewed Pneumatech's landfill gas/digester drying systems*



*Mike Downey and Liane Callow from SPVG (Steel Pressure Vessel Group) explained that they regularly build tanks between 3,000–30,000 gallons in size to support system assessment work*



*Rodney Rushing and Kent Brandon of Summit Industrial Products reported sales growth from their line-up of air compressor lubrication products*



# RESOURCES FOR ENERGY ENGINEERS

## TRAINING CALENDAR

TITLE	SPONSOR(S)	LOCATION	DATE	INFORMATION
Compressed Air Challenge® Advanced Mgmt of Compressed Air Systems	Atlas Copco ComEd-Energy Efficiency Services	Oak Brook, IL	11/8/10–11/9/10	Giuliana Losurdo Tel: 847-981-2627 email: giuliana.losurdo@us.atlascopco.com
Fundamentals of Compressed Air Systems	Kentucky Pollution Prevention Center, Kentucky Department for Energy Development, DOE EERE, Compressed Air Challenge®	Louisville, KY	11/11/10	Lisa Tatum Wease Tel: 502-852-0148 www.compressedairchallenge.org
Compressed Air Challenge® Fundamentals of Compressed Air Systems	Purdue University Indiana University	Fort Wayne, IN	11/17/10	Monica Cannaley Tel: 317-275-6822 email: mcannale@purdue.edu
Compressed Air Challenge® Fundamentals of Compressed Air Systems	Online Training	web-edition	11/23/10	www.compressedairchallenge.org info@compressedairchallenge.org
Airmaster+	Focus on Energy, SAIC, DOE EERE, Compressed Air Challenge®	Appleton, WI	12/7/10–12/10/10	Robin Smith Tel: 414-763-9952 www.compressedairchallenge.org
Fundamentals of Compressed Air Systems	Southern California Gas Company, California Energy Commission, Compressed Air Challenge®, DOE EERE	Downey, CA	1/12/11	Larry Bennett Tel: 562-803-7570 www.compressedairchallenge.org
Advanced Management of Compressed Air Systems	Southern California Gas Company, California Energy Commission, Compressed Air Challenge®, DOE EERE	Downey, CA	2/16/11–2/17/11	Larry Bennett Tel: 562-803-7570 www.compressedairchallenge.org

*Editor's Note: If you conduct compressed air system training and would like to post it in this area, please email your information to [rod@airbestpractices.com](mailto:rod@airbestpractices.com).*

## PRODUCTS

### Boge Extends Range of Oil-Free Piston Compressors

Boge has extended the K-Series oil-free piston compressor range with the addition of 15 and 40 bar options. The new models incorporate the same compressor technology utilized in developing the K-Series oil-free piston compressors. The cylinder is mounted horizontally, and a centrally located crankshaft operates a push rod principal, ensuring the piston remains parallel in the cylinder. This innovation vastly reduces cylinder ring wear experienced in all conventional systems.

The K-Series design provides a cost-effective compressor solution for the smaller compressed air user. As an oil-free compressor, the K-Series reduces the downstream treatment required and all the associated costs. Service times and standard service parts required are also reduced considerably. Additionally, unlike most piston compressors, the K-Series operates on a stop/start basis, controlled by a standard Boge electronic controller, which further ensures the most efficient use of energy.

The K-Series does not use an oil-lubricated crosshead drive, and so as a 100% oil-free piston compressor, this range is ideally suited to industries such as the food, drink, medical and pharmaceutical sectors, where oil-free compressed air is paramount. The package, with acoustic canopy, can be receiver mounted and requires a minimal footprint, underpinning its versatility in, for example, point-of-use applications. The K-Series is available as a 150, 220 or 580 psi compressor with effective free air deliveries ranging from 8.5–46 cfm and motor range of 3–15 hp.

*BOGE America*  
Tel: 770-874-1570  
E-mail: [usa@boge.com](mailto:usa@boge.com)  
[www.boge.com/us](http://www.boge.com/us)



## PRODUCTS

### Gatorade Plant Saves \$70,000 with Compressed Air Control System

When an independent energy consultant recommended air compressor controls, Gatorade turned to Pneu-Logic's PL4000 Compressed Air Control System. With seven compressors in three locations and no monitoring in place to observe system-wide pressures, the compressors at the Tolleson, Arizona plant consistently maintained higher than necessary power usage, regardless of production requirements.

After installing the PL4000, the amount of energy required to run the compressed air system was reduced by 21%, for an annual savings of \$70,000 or 1.1 Million kWh. "It was started and tuned for optimum performance — quickly and while the plant was in full production," said Tom Schaefer, principal engineer at PepsiCo's Quaker, Tropicana, Gatorade Energy Group. "The system is user friendly, expandable and provides detailed information about the entire compressed air system, which can be used for troubleshooting and energy reduction planning."

The PL4000 uses flow-based compressor staging tables and strategies to select optimal compressor combinations, wherein only one compressor is the trim, and the remaining are base compressors operating at full load, unloaded or off.

The total investment in this project was \$175,000, which covered infrastructure (piping expansion) and PL4000 installation. This was offset by a \$70,000 incentive provided by a local utility. The IRR (inclusive of incentive) was 35.7% with a 1.5 year payback. PepsiCo (an ENERGY STAR® Partner) is currently looking at installing the Pneu-Logic solution at additional plants in the division.

*Pneu-Logic Corporation*  
Tel: 866-348-5669  
E-mail: [info@pneulogic.com](mailto:info@pneulogic.com)  
[www.pneulogic.com](http://www.pneulogic.com)



### Zebra Skimmers Expands Muscle™ Coalescer Line

Zebra Skimmers Corporation, a full-line manufacturer of oil skimmers and industrial fluid maintenance equipment, expands its Muscle Coalescer line to include a new model for servicing air compressor condensate.

"The Muscle Coalescer line has been solid for many years, servicing our customers' needs for the separation and removal of contaminate oil from water-based fluids. Due to environmental concerns, many industries desire, or are required, to treat their compressor condensate before it's released to the sewer. This new coalescer model is a simple and cost-effective solution, preventing environmental contamination while reducing the overall compressor waste stream," states Meg Grant, sales and service manager of Zebra Skimmers Corporation.

Benefits of the Muscle Compressor Coalescer include:

- Robust, yet simple, design fits any budget
- Automatic air release vent and de-oiled water exit
- Reduces compressor waste stream up to 98%
- Works with almost any size compressor
- Lifetime warranty 

*Zebra Skimmers*  
Tel: 888-249-4855  
Email: [Meg@ZebraSkimmers.com](mailto:Meg@ZebraSkimmers.com)  
[www.ZebraSkimmers.com](http://www.ZebraSkimmers.com)





# WALL STREET WATCH

BY COMPRESSED AIR BEST PRACTICES®

The intent of this column is to provide industry watchers with publicly held information, on publicly held companies, involved with the sub-industry of compressed air. It is not the intent of the column to provide any opinions or recommendations related to stock valuations. All information gathered in this column was during the trading day of October 22, 2010.

OCTOBER 22, 2010 PRICE PERFORMANCE	SYMBOL	OPEN PRICE	1 MONTH	6 MONTHS	12 MONTHS	DIVIDEND (ANNUAL YIELD)
Parker-Hannifin	PH	\$76.16	\$69.46	\$70.13	\$56.41	1.42%
Ingersoll Rand	IR	\$38.51	\$35.79	\$36.80	\$34.74	0.72%
Gardner Denver	GDI	\$58.00	\$53.44	\$50.90	\$37.81	0.35%
Atlas Copco ADR	ATLCY	\$19.26	\$16.37	\$15.12	\$12.16	2.03%
United Technologies	UTX	\$74.98	\$70.43	\$76.52	\$65.26	2.27%
Donaldson	DCI	\$49.08	\$46.23	\$46.60	\$38.02	1.02%
SPX Corp	SPW	\$67.34	\$63.57	\$65.47	\$59.77	1.48%

## Gardner Denver Reports Third Quarter 2010 Earnings

Gardner Denver, Inc. (NYSE: GDI) announced that revenues and operating income for the three months ended September 30, 2010 were \$493.4 million and \$68.0 million, respectively, and net income and DEPS attributable to Gardner Denver were \$46.6 million and \$0.88, respectively. For the nine-month period of 2010, revenues and operating income were \$1,365.1 million and \$172.1 million, respectively, and net income and DEPS attributable to Gardner Denver were \$115.9 million and \$2.20, respectively.

Compared to the three-month period of 2009, revenues increased 15%, orders increased 33% and operating income increased 112%. The improvement in orders for Industrial Products occurred in North America and Asia Pacific, with relatively stable demand for products in Europe. Demand for Engineered Products increased in all business units, with the most significant increases resulting from incremental demand for petroleum products and loading arms.

Operating income more than doubled compared to the three-month period of the prior year, increasing by \$35.9 million from \$32.1 million in 2009. Operating income as a percentage of revenues was 13.8% in the three-month period of 2010, compared to 7.5% in the prior year period. The increase in

operating income in the three-month period of 2010, compared to the prior year period, was largely driven by incremental profitability on the revenue growth, favorable product mix and the benefits of operational improvements previously implemented.

## CEO's Comments

"The third quarter 2010 financial results reflect the best end-market demand and operational performance for Gardner Denver since the third quarter of 2008," said Barry L. Pennypacker, Gardner Denver's president and chief executive officer. "In addition to some general improvement in demand for our Industrial Products in North America, in the third quarter we benefited from significantly higher orders for these products in Asia Pacific, compared to the same period in 2009, primarily due to investments in infrastructure projects. In the third quarter, Engineered Products also received orders for infrastructure investments, such as an order for loading arms destined for the Middle East (approximately \$14 million) and an order for engineered packages for Brazil (approximately \$9 million). Both of these orders are expected to ship mid-2011, so our view into next year is gradually improving. The Company also benefited from investments in shale development in North America, resulting in strong demand and increased backlog for drilling and well servicing pumps, which provides somewhat improved clarity into early 2011."

"We have focused on process improvements and completed capital investments, which have given us the ability to reduce costs even as we accelerate production output as demand recovers," Pennypacker continued. "Due to our efforts, we have been able to respond to the increase in orders with additional output and generate incremental profitability on the revenue growth. We continue to expand our knowledge and practical experience with new applications of our business system, 'The Gardner Denver Way'. The benefit of our efforts can be seen in our significant progress toward our goal of 14% operating margin in the Industrial Products segment by achieving operating margin of 9.4% for this segment in the three-month period of 2010. We also see the benefit of our efforts in our inventory turnover, which improved to 5.6 times as of September 30, 2010 from 4.9 times as of September 30, 2009. This is an important milestone for Gardner Denver in that this is the highest turnover in our history. Our process improvements are working and we believe further opportunities exist to improve our processes and productivity in both reportable segments as we continue our transformation into a lean organization."

"On a year-to-date basis, cash provided by operating activities was more than \$153 million, or 132% of net income attributable to Gardner Denver. For the year-to-date period, cash flow from operating activities, less capital expenditures, also exceeded



net income attributable to Gardner Denver, and we expect this performance to continue for the fourth quarter as well. The Company used this cash flow to reduce its borrowings and complete a small acquisition in July. As of September 30, 2010, debt-to-total capital was 20.8%, which should position the Company to repurchase shares or make additional acquisitions, if the appropriate opportunities become available.

**Outlook**

Mr. Pennypacker stated, “We expect continued revenue growth for the balance of 2010 as a result of ongoing volume improvements in aftermarket parts and services, and OEM and petroleum products. Our outlook also includes a significant shipment of LNG loading arms in the fourth quarter of 2010, which is expected to contribute approximately \$12 million to revenues. We believe that increases in capacity utilization are leading to improvements in demand for aftermarket parts and services for industrial equipment and some replacement unit opportunities for certain compressors, but do not feel that capacity utilization has increased sufficiently to warrant significant capital investments by manufacturing companies. As a result of our expectation for a slow economic recovery, we anticipate revenues for our Industrial Products to grow slightly in the fourth quarter but continue to remain cautious in our outlook.”

“Revenues for Engineered Products depend more on existing backlog levels than revenues for Industrial Products, and orders for Engineered Products are frequently scheduled for shipment over an extended period of time. Many of these products are used in process applications, such as oil and gas refining and chemical processing, which are industries that typically experience increased demand very late in an economic cycle. At present, orders for products used in process applications are primarily for replacement units, aftermarket parts and services or for infrastructure investments in developing countries. Our current outlook assumes that drilling pump shipments improve in the fourth quarter of 2010 and that demand for well servicing equipment and OEM compressors remain strong through the balance of the year,” he said.

Mr. Pennypacker stated, “Based on this economic outlook, our existing backlog and productivity improvement plans, we are projecting the fourth quarter 2010 DEPS to be in a range of \$0.94– \$0.99 and our full-year 2010 DEPS to be in a range of \$3.14–\$3.19.” **BP**

**COMPRESSED AIR BEST PRACTICES®**  
**www.airbestpractices.com**

**ADVERTISER INDEX**

Company	Page	Web Site
Kaeser Compressors	Outside Back Cover	www.kaeser.com
World Energy Engineering Conference	Inside Back Cover	www.energycongress.com
Atlas Copco	Inside Front Cover	www.atlascopco.com
Hitachi	3	www.hitachi.us/airtech
SPX Hankison	7	www.hankisonintl.com
Sullair Compressors	9	www.sullair.com
Chicago Pneumatic	11	www.cp.com
Ingersoll Rand	13	www.ingersollrand.com
EDMAC	15	www.edmac.com
JORC Industrial	17	www.jorc.com
ALMIG U.S.A.	19	www.almig.us
CDI Meters	21	www.cdimeters.com
Walker Filtration	23	www.walkerfiltration.com
Aircel Corporation	25	www.aircelcorp.com
Gardner Denver	27	www.gardnerdenver.com
FS Curtis Air Compressors	29	www.fscurtis.com
Thermal Transfer Products	31	www.thermaltransfer.com
Vaisala	33	www.vaisala.com
Mattei Compressors	35	www.matteicomp.com
Airleader	37	www.airleader.us
Hannover Messe	41	www.hannovermesse.de/comvac_e

**COMPRESSED AIR BEST PRACTICES®**  
**www.airbestpractices.com**

**Advertising & Editorial** : **Rod Smith**  
rod@airbestpractices.com  
Tel: 412-980-9901

**Subscriptions & Administration** : **Patricia Smith**  
patricia@airbestpractices.com  
Tel: 412-980-9902

**A Publication of** : **Smith Onandia Communications LLC**  
217 Deer Meadow Drive  
Pittsburgh, PA 15241

Compressed Air Best Practices® is published monthly by Smith Onandia Communications LLC., 217 Deer Meadow Drive, Pittsburgh, PA 15241. Phone 412-980-9902, email patricia@airbestpractices.com. Compressed Air Best Practices® is a trademark of Smith Onandia Communications, LLC. Publisher cannot be held liable for non-delivery due to circumstances beyond its control. No refunds. Standard postage is paid at 233 Jefferson Street, Greenfield, Ohio 45123. Canadian and international distribution: IMEX International Mail Express, 1842 Brummel Drive, Elk Grove Village, IL 60007. POSTMASTER: Send address changes to Compressed Air Best Practices®, 217 Deer Meadow Drive, Pittsburgh, PA 15241. SUBSCRIPTIONS: Qualified reader subscriptions are accepted from compressed air professionals, plant managers, plant engineers, service and maintenance managers, operations managers, auditors, and energy engineers in manufacturing plants and engineering/consulting firms in the U.S. To apply for qualified reader subscriptions, please fill in the reader response cards herein and mail or fax or go to www.airbestpractices.com. To non-qualified subscribers subscriptions are \$65 in Canada and \$95 for other countries. When available, extra copies of back issues are \$4 plus shipping. Contact Patricia Smith for subscription information at tel: 412-980-9902 or email: patricia@airbestpractices.com. REPRINTS: Reprints are available on a custom basis, contact Patricia Smith for a price quotation at tel: 412-980-9902 or email: patricia@airbestpractices.com. All rights are reserved. The contents of this publication may not be reproduced in whole or in part without consent of Smith Onandia Communications LLC. Smith Onandia Communications LLC does not assume and hereby disclaims any liability to any person for any loss or damage caused by errors or omissions in the material contained herein, regardless of whether such errors result from negligence, accident, or any other cause whatsoever. Printed in the U.S.A.



# THE MARKETPLACE

## TECHNOLOGY

**BELT OIL SKIMMERS** lift and collect oil floating on water in pits, drums or wells! Big selection of types & collection rates! 1-800-255-5665  
[www.wayneproducts.com](http://www.wayneproducts.com)  
[info@wayneproducts.com](mailto:info@wayneproducts.com)

COMPRESSED AIR  
**BEST PRACTICES**

EXHIBIT AT THE  
HANNOVER FAIR

APRIL 4-8, 2011

Turnkey booths at the  
Compressed Air Best  
Practices® Pavilion.



[www.airbestpractices.com/magazine/](http://www.airbestpractices.com/magazine/)

### PROVEN DATA LOGGING SOLUTIONS

Where are  
the Cost Savings?



Non-invasive Install  
Tell-all Graphical Proof

Bad electricity usage wastes energy not to mention being bad for the environment. ACR Electric Current Data Loggers reveal the information needed to make informed decisions on energy conservation **24/7 - 365** days a year.

Best Warranty and Customer Service



Tel: 604.591.1128  
Toll-Free: 1.800.663.7845  
Email: [info@acrsystems.com](mailto:info@acrsystems.com)

ISO 9001:2000

[www.acrsystems.com/374](http://www.acrsystems.com/374)

COMPRESSED AIR  
**BEST PRACTICES**  
FREE SUBSCRIPTION  
DIGITAL EDITION FREE WORLDWIDE  
PRINT EDITION FREE TO U.S. SUBSCRIBERS



### 2011 FOCUS INDUSTRIES!

Concrete Bulk Handling, Pharmaceutical, Automotive Manufacturing, Lumber Pulp & Paper, System Assessments, Plastics Blow Molding, Food Packaging, Wastewater Treatment, Food Processing, Air Compressor Controls & Monitoring

Subscribe at [www.airbestpractices.com](http://www.airbestpractices.com)

## COMPRESSED AIR BEST PRACTICES® MARKETING SERVICES

HELPS DISTRIBUTORS AND OEM'S WITH ALL THEIR MARKETING NEEDS

- Print magazine ads
- Web site ads on [www.airbestpractices.com](http://www.airbestpractices.com)
- Compressed Air Best Practices® e-Newsletters
- Market research questionnaires for NPDP
- Web site design
- e-mailer campaigns
- Brochure and direct mailer design
- Marketing strategy consulting
- Training seminars

COMPRESSED AIR  
**BEST PRACTICES**  
MARKETING SERVICES

Contact Rod Smith for  
a personalized proposal.  
[rod@airbestpractices.com](mailto:rod@airbestpractices.com),  
Tel: 412-980-9901

# 33rd WORLD ENERGY ENGINEERING CONGRESS

**December 8-10, 2010**  
Washington Convention Center  
Washington, DC

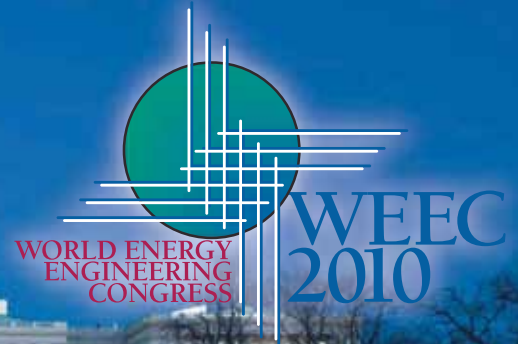

PRESENTED BY



HOSTED BY



FEATURING



*Recognized as the most important energy event of national scope for end users and energy professional in all areas of the energy field.*

*It is the one truly comprehensive forum where you can fully assess the "big picture" – and see exactly how the economic and market forces, new technologies, regulatory developments and industry trends all merge to shape your critical decisions on your organization's energy and economic future.*

#### Keynote Speaker



**Thomas L. Friedman**  
World renowned journalist and author. Speaking on opening session on Wednesday, Dec. 8, 2010

**The World Energy Engineering Congress (WEEC)** and expo target the complete spectrum of technologies and services of greatest importance to our delegates in attendance, including, but not limited to:

*The Green Jobs Explosion • Energy & Policy Legislation • Government Energy Management – New Rules Strategies & Sustainability for Green Buildings • Lighting Controls • Climate Risk Management  
Existing Building Commissioning • Superior Energy Performance for Industry  
Energy & Carbon Reduction Success Stories • Alternative Energy*

Also, in order to address the interests and needs of the large number of U.S. government professionals who traditionally attend WEEC, AEE will again offer a section of the program known as **FEMWorks 2010**. First introduced as part of the 2006 WEEC agenda, this special multi-track portion of the WEEC conference will include a comprehensive series of workshops for federal energy managers.

[www.energycongress.com](http://www.energycongress.com) • 770-447-5083 • [info@aeecenter.org](mailto:info@aeecenter.org)



# Chances are, you'll retire before your Kaeser compressor.

If you're looking for the best lifetime value in air compressors today, look no further than Kaeser. When you consider our durability, performance and easy maintenance – all rolled into one – we're the most reliable compressed air equipment you can buy, hands down.

Every compressor we build stands up to the toughest conditions, for years of trouble-free operation. Superior energy efficiency and easy service just add to the benefits and savings you receive. Plus, with a full range of sizes and models to choose from, there's a Kaeser compressor that will meet your specific needs.

To learn more about Kaeser value and “built for a lifetime” engineering, call us toll-free or visit [www.kaeser.com/sigma](http://www.kaeser.com/sigma).



**KAESER  
COMPRESSORS**

*Built for a lifetime.™*

[www.kaeser.com/sigma](http://www.kaeser.com/sigma)  
(866) 516-6888



**Kaeser Compressors, Inc.** ■ (866) 516-6888 ■ [info.usa@kaeser.com](mailto:info.usa@kaeser.com)  
Built for a lifetime is a trademark of Kaeser Compressors, Inc. ©2009 Kaeser Compressors, Inc.

