

COMPRESSED AIR BEST PRACTICES[®]

airbestpractices.com

June 2014



Energy-Efficiency System Assessments

- 12 Global Energy Management at Corning
- 24 ENERGY STAR[®] Sustains Excellence
- 30 Evaluating Operational Costs of Sandblasting

16 NORTHWEST PUMP & EQUIPMENT PROFILE





INTERACTION. COMMITMENT. INNOVATION.

These are the drivers that have helped Atlas Copco develop industry-leading compressed air systems for virtually every application in nearly every industry.

We design, engineer and manufacture our own compressor screw elements with the highest attention to quality to satisfy your need for economic performance, reduced energy costs and improved productivity.

When you're looking for a compressed air solution, look no further than Atlas Copco.

www.atlascopco.us – 866-688-9611

Sustainable Productivity

Atlas Copco

“ **The efficiency and reliability of Hitachi compressors save us time and money.** ”

The world's largest spice maker relies on Hitachi Oil-Free Air Compressors to reduce operating costs, maintain production uptime and improve worker utilization.

Oil-free compressors from Hitachi Industrial Equipment are proven more reliable than alternative solutions. Unlike other suppliers, Hitachi designs and manufactures most of the major components of its oil-free air compressors in-house, resulting in greater reliability and more consistent efficiency over the life of the equipment.

Discover how other companies have achieved production uptime objectives and better managed costs with Hitachi Industrial Equipment oil-free compressors.

Visit us at www.hitachi-america.us/oil-free-compressors/



Hitachi's experience and know-how developing ultra-reliable technologies for critical infrastructure like high speed rail systems and turbine power generators influence the design and production of Hitachi's super-efficient oil-free air compressors.

Hitachi Industrial Equipment
Hitachi Industrial Equipment Systems Co., Ltd.

HITACHI
Inspire the Next

SUSTAINABLE MANUFACTURING FEATURES

- 12 Global Energy Management at Corning**
By Rod Smith, Compressed Air Best Practices® Magazine
- 16 Distributor Profile: Northwest Pump & Equipment**
By Rod Smith, Compressed Air Best Practices® Magazine
- 24 ENERGY STAR® Sustains Excellence**
By Rod Smith, Compressed Air Best Practices® Magazine
- 30 Evaluating Operational Costs of Sandblasting**
By Scott van Ormer, Air Power USA
- 34 Operating a Split Trim/Base System**
By Ron Marshall for the Compressed Air Challenge®



COLUMNS

- 5 From the Editor**
- 6 Industry News & Sustainability Reports**
- 41 Resources for Energy Engineers**
Technology Picks
- 48 The Marketplace**
Jobs and Technology
- 49 Advertiser Index**





FROM THE EDITOR

Energy-Efficiency System Assessments



I had the distinct pleasure of attending the 2014 ENERGY STAR® Awards, held this past month in Washington D.C. For someone like me, who drank the energy conservation Kool-Aid long ago, this was like going to the All-Star Game! Industry-leading companies were present to receive Partner of the Year Awards for their sustained excellence in energy management.

This voluntary program, run by the Environmental Protection Agency, is a shining example of great work by a governmental agency. I hope you'll review my article interviewing Betsy Dutrow, the ENERGY STAR Director of Industrial Partnerships.

A freshly-minted ENERGY STAR® Partner of the Year is Corning Incorporated. One of the world's largest specialty glass manufacturers, Corning launched their Global Energy Management program in 2006 using ENERGY STAR resources as their guide to create the program. I hope you enjoy our interview article with Patrick Jackson, the Director of Global Energy Management for Corning. He shares with us the tale of their journey creating a process that has led to \$328 million in cumulative energy savings.

Northwest Pump & Equipment allowed us to sit down and talk with them about their business strategies. Representing Sullair Compressor products in a significant portion of the western U.S., this Company, founded in 1959, employs 300 people and leverages synergies between pumps, blowers and air compressors in their Industrial Division.

I'm always very grateful to Air Power USA for sharing with us their "compressed air demand reduction" techniques. In this issue, Scott van Ormer discusses sandblasting systems and how easy it is for the costs associated with compressed air to spiral. The selection of nozzle orifice size and pressure at the nozzle has a profound impact on operational costs.

Kitchen Craft of Canada is a large kitchen cabinet manufacturer in Winnipeg, Manitoba. Ron Marshall, on behalf of the Compressed Air Challenge®, writes about how they installed a unique compressed air control system where base compressors operate on the low-pressure side of a pressure/flow controller, and trim compressors operate at higher pressure. This arrangement helps keep operating costs very low and saves significant operating costs over a typical system.

Summer has finally arrived in the northeast! Enjoy and thank you for investing in **Compressed Air Best Practices®**.

ROD SMITH

Editor

tel: 412-980-9901, rod@airbestpractices.com

COMPRESSED AIR BEST PRACTICES® EDITORIAL ADVISORY BOARD

	Member Name	Position	Company
Industrial Energy Managers	Doug Barndt	Manager, Demand Side Energy-Sustainability	Ball Corporation
	Eric Battino	Productivity Senior Manager	PepsiCo
	Richard Feustel	Senior Energy Advisor	Leidos
	Brad Ikenberry	Energy Manager, North America	Michelin
	William Jerald	Energy Manager	CalPortland
	Jennifer Meier	Global EH&S/ Plant Engineering Manager	Varroc Lighting Systems
	Thomas Mort	Energy Director	Archer Daniels Midlands
	Brad Reed	Corporate Energy Team Leader	Toyota
	Brad Runda	Global Director, Energy	Koch Industries
Compressed Air System Assessments	Don Sturtevant	Corporate Energy Manager	Simplot
	Jay Francis	Director, Global Product Management & Strategic Accounts	SPX Flow Industrial
	Tilo Fruth	President	Beko USA
	Chris Gordon	President	Blackhawk Equipment
	Paul Humphreys	General Manager	Edmac Compressor Parts
	Paul Johnson	Global Sales Manager	Parker Hannifin
	Kurt Kondas	President	Universal Air & Gas Products
	Mark Krisa	Director Global Service Solutions	Ingersoll Rand
	Frank Langro	Director Marketing / Product Management	Festo
	Ron Marshall	Customer Engineering Services	Compressed Air Challenge®
	Pierre Noack	President	Aerzen USA
	Wayne Perry	Technical Director	Kaeser Compressors
	Andy Poplin	Sales Manager	Atlas Machine & Supply
Nitin Shanbhag	Senior Manager, Industrial Division	Hitachi America	
Richard Stasyshan	Technical Director	Compressed Air & Gas Institute	
Hank Van Ormer	President	Air Power USA	

COMPRESSED AIR
BEST PRACTICES supports:
airbestpractices.com





INDUSTRY NEWS & SUSTAINABILITY REPORTS

Quincy Compressor to Acquire Compressed Air Assets of Texas Distributors

Quincy Compressor has agreed to acquire the compressor related assets of National Pump & Compressor's (NPC) and the assets of McKenzie Compressed Air both with multiple locations in Texas. Recent developments in the Texas and Alabama markets provided Quincy an opportunity to incorporate the assets of these two strong distributors into its business.

"Quincy customers in Texas and Alabama can rely on the direct stores in nine locations primarily in Dallas, Houston, San Antonio and Mobile," said John Thompson, President Quincy Compressor. "With NPC and McKenzie exiting the market, we plan to build on the successes of these companies, strengthen our brand presence and continue to bring high quality products and services to our customers."

About 125 employees in a variety of sales and service roles joined Quincy Compressor from NPC and McKenzie. The acquired branches now form Quincy's direct sales and service centers in Texas, which ranks as one of the largest and most rapidly growing economies in the United States. As a key industrial and manufacturing hub of the American economy, it serves a broad range of manufacturing sectors including oil and gas, energy, chemical and general industry.

Headquartered in Bay Minette, Alabama, Quincy Compressor is a leading designer and manufacturer of reciprocating and rotary screw air compressors, from one-third to 350 horsepower; vacuum pumps and a full line of air treatment components. Quincy also operates facilities in Quincy, Illinois and in Kunshan, China with more than 600 employees worldwide. Its products are sold through multiple channels, including a network of distributors, commercial retailers, online and company-owned stores.

About Quincy Compressor: Quincy Compressor is a leading designer and manufacturer of reciprocating and rotary screw air compressors, vacuum pumps and a full line of air treatment components. In business since 1920, Quincy has built its reputation on quality and rugged reliability, building tough air compressors for the most demanding applications.

For more information, visit quincycompressor.com

Atlas Copco Biogas Screw Compressors Installed

Streicher Anlagenbau GmbH & Co. KG, one of the largest constructors of biogas supply plants in Germany, has installed two Atlas Copco GG 90 compressors with variable speed drive (VSD) at a plant in Geislingen. The two compressors, which have been specially designed for the biogas market, are used to compress the gas to 14 bar for distribution into the medium-pressure network of the local energy supply net.

Streicher Anlagenbau constructs biogas treatment and supply plants, among other facilities. Biogas treatment plants clean the raw biogas that comes from a producer's biogas plant and prepare the gas to be passed on to energy suppliers. Supply plants condition the biogas to be fed into the local gas network.

The processed gas must meet strict regulatory requirements before it is permitted to be fed into the natural gas grid. To do so, adjustments need to be made to the wobe index value and especially the pressure. "We receive the treated biogas at a pressure of around one bar," explains Thomas Kunze, Project Manager at Streicher Anlagenbau. "However, we have to supply it at a pressure of 10 to 14 bar."

Compressors meet high safety requirements

To bring the gas up to this higher pressure, Atlas Copco GG 90 VSD gas screw compressors are used in the supply plant. Atlas Copco entered the biogas market several years ago and has developed machines especially suited to this industry. The GG VSD series, is one example of these specially developed machines.

Equipment for gas compression must meet more stringent safety requirements than conventional compressors, such as being gas-tight and compliance with ATEX Zone 1 & 2. Furthermore, gas production continuously varies. The gas compressor therefore must continuously adjust to this changing inlet conditions yet keeping constant delivery pressure. This is achieved with variable speed compression.

"The GG can take in gas at a pressure of 1.1 to 1.4 bar(a) and compress it up to a pressure of 16 bar(a)." explains Robert Liebl, biogas expert at Atlas Copco. "The GGs also operate reliably because the oil-lubricated screw element is very similar to its counterpart in the GA machines."

Reliability and redundancy necessary in plant operations

Energy suppliers generally demand an availability rate of 97% from the plant manufacturer as the biomethane production cannot be stopped. *“To achieve and maintain this extremely high figure, all biogas supply plants are built with total redundancy,”* clarifies Thomas Kunze. Compressors, heaters, gas tanks, pressure regulator fittings, and measuring systems, among other things, are duplicated so that the failure of a system does not disrupt supply.

For this purpose, there are two speed-regulated GG compressors at the plant in Geislingen, each of which is capable of compressing 500 standard cubic meters of gas per hour. The compressors adapt to conditions by means of suction pressure control. *“The expertise is in the control system,”* stresses Thomas Kunze. *“All the components must be precisely attuned to each other.”*

The GG gas compressors feature a single-stage compression process and are water-cooled, speed-regulated and directly driven. This means that they also operate in a very energy-efficient manner.

This is the second plant that Streicher has equipped with Atlas Copco gas compressors since September 2013. *“We have had very good experiences with the GGs to date,”* says Kunze. *“The machines are simply constructed, operate absolutely reliably and, therefore, guarantee the high level of availability that we need.”* Ultimately, the plants are intended to supply gas for at least 20 years.

*For further information please contact: Jacky Joas, Business Development Manager, Gas Compression and Purification
Tel: +41 (0)61 827 35 55 or jacky.joas@cb.atlascopco.com*

Atlas Copco is a world-leading provider of sustainable productivity solutions. The Group serves customers with innovative compressors, vacuum solutions and air treatment systems, construction and mining equipment, power tools and assembly systems. Atlas Copco develops products and service focused on productivity, energy efficiency, safety and ergonomics. The company was founded in 1873, is based in Stockholm, Sweden, and has a global reach spanning more than 180 countries. In 2013, Atlas Copco had revenues of BSEK 84 (BEUR 9.7) and more than 40 000 employees. Learn more at www.atlascopco.com





precision | expertise | innovation | experience
We set the standard.
 +1 (404) 924-6900 | www.bekousa.com

air treatment | condensate technology | instrumentation | hydrocarbon removal systems

Have you experienced



*"It's nice to work with people who care...
it's so rare these days. Thanks again!"*

- A loyal customer in the West

Experience. Customer. **Service**...n-psi
704-897-2182
n-psi.com

INDUSTRY NEWS & SUSTAINABILITY REPORTS

Atlas Copco's Compressor Technique business area provides industrial compressors, vacuum solutions, gas and process compressors and expanders, air and gas treatment equipment and air management systems. The business area has a global service network and innovates for sustainable productivity in the manufacturing, oil and gas, and process industries. Principal product development and manufacturing units are located in Belgium, Germany, the United States, China and India.

EPA Honors 2014 Energy Star Partners of the Year

The U.S. Environmental Protection Agency (EPA) and the U.S. Department of Energy (DOE) are honoring 127 organizations for their commitment to protecting the environment through superior energy efficiency. Recipients of the 2014 Energy Star Partner of the Year Award include Des Moines Public School District; KB Home; Meritage Homes Corporation; PepsiCo., Inc.; Sears Holdings Corporation; and Samsung.

"EPA applauds this year's Energy Star Partner of the Year Award winners, who have demonstrated innovative strategies to help their customers, partners and stakeholders save energy and cut greenhouse gas emissions," said EPA Deputy Administrator Bob Perciasepe. "Their commitment to saving energy helps fight climate change while also helping their bottom line." "Each year, Energy Star partners create jobs, protect the environment and raise the bar for the home improvement industry through their dedication to energy efficiency," said Assistant Secretary for Energy Efficiency and Renewable Energy David Danielson. "This national program helps homeowners by providing access to innovative home improvement solutions and enabling American families to save money by saving energy."

The winners were selected from 16,000 Energy Star partners, including manufacturers, retailers, public schools, hospitals, real estate companies, and home builders, for their dedication to protecting the environment through greater energy efficiency.

Organizations are recognized in the following categories:

Partner of the Year — Sustained Excellence: The 72 Sustained Excellence winners continue to exhibit exceptional leadership year after year in the Energy Star program while remaining dedicated to environmental protection through superior energy efficiency.

Partner of the Year: Forty-five organizations are receiving the Partner of the Year award for



strategically and comprehensively managing their energy use. These organizations promote Energy Star products and practices in their own operations, in addition to providing efficient products and services to consumers and within their community.

Partner of the Year — Climate Communications: The 10 Climate Communications winners have raised their customers' awareness of the impacts of climate change. These partners have created communications that encourage their customers to combat climate change with the help of Energy Star and emphasize how energy-efficient behaviors have a positive effect on the environment.

Excellence: Nine winners are receiving awards in part for their superior efforts in the Home Performance with Energy Star program. The remaining organizations are receiving Excellence Awards for specific activities to promote energy-efficient products, homes, or buildings.

Products, homes and buildings that earn the Energy Star label prevent greenhouse gas emissions by meeting strict energy efficiency requirements set by the U.S. EPA. From the first Energy Star qualified

computer in 1992, the Energy Star label can now be found on products in more than 70 different categories, with more than 4.5 billion sold. Over 1.5 million new homes and 23,000 office buildings, schools and hospitals have earned the Energy Star label. Since the Energy Star program began, American families and businesses have saved \$297 billion on utility bills and prevented more than 2.1 billion metric tons of greenhouse gas emissions with help from Energy Star.

Complete list of winners: www.energystar.gov/awardwinners

Bosch Rexroth Becomes Aventics

Something's happening in the international pneumatics market: a new standalone company has been created out of the former Pneumatics business unit at Bosch Rexroth. Due to a change in ownership, the medium-sized company is now ready to take on the competition around the world under the name AVENTICS.

For the first time in decades, a pneumatics competitor is completely reestablishing itself: with a new name, new values, and a new

COMPRESSED AIR ALSO PRODUCES OILY CONDENSATE*

Help ensure it doesn't impact our **ENVIRONMENT.**



JORC Zero Air-Loss Condensate Drains and Oil/Water Separators provide SUSTAINABLE CONDENSATE MANAGEMENT

Sepremium Oil/Water Separator

*A 250 hp compressor can produce 40,515 gallons of oily condensate per year.

Zero Air-Loss Condensate Drains

Electronic



Smart Guard Ultra



Smart Guard

No Electricity Required



Mag-11 - 230 psi



POD-DC Non-Electric

Lock-Down Air Leaks



Air-Saver G2



JORC Industrial LLC • 1146 River Road • New Castle, DE 19720
Phone: 302-395-0310 • Fax: 302-395-0312 • info@jorc.com • www.jorc.com

INDUSTRY NEWS & SUSTAINABILITY REPORTS



*Dr. Alexander Lawrence, Chief Sales Officer,
AVENTICS GmbH*

company structure. With these changes, the pneumatics specialists with global headquarters in Laatzen, Germany (near Hanover) are ringing in the next generation of pneumatics. “The new name combines

the terms of advantage, invention, and pneumatics, and therefore describes what we are aiming for: our customers will get added value with our innovative products, system solutions, and services,” explains Dr. Alexander Lawrence, one of three members of the Board at AVENTICS GmbH. Advantages are, for example, improved quality of consulting and reaction time.

Under the new name, the manufacturer of pneumatics components and systems intends to further expand its market position. In the future, AVENTICS will also address industries that the company has not globally focused on previously. Proven products and a clear focusing on customer needs will come under the company’s umbrella, along with global presence and individual customer

solutions. “We are connecting the best of two worlds: in AVENTICS, a long tradition and the solid expertise of our employees meets the flexibility of a medium-sized company,” emphasizes Dr. Lawrence.

In the U.S., headquarters remain in Lexington, Kentucky, and in Canada, headquarters remain in Burlington, Ontario. In its new position as a medium-sized business, the company, which has 2,100 employees, sees many opportunities around the globe. In the future, AVENTICS will communicate more directly and engagingly with its customers, the majority of whom are also medium-sized companies.

About AVENTICS

AVENTICS is a globally active manufacturer of pneumatic components and systems. The company is also a specialist supplier of drive and control solutions for the marine industry and commercial vehicles, as well as inverted tooth chains for production processes. The former subsidiary of Bosch Rexroth has been operating as a standalone company since the start of 2014.

AVENTICS offers its customers tailored, cross-industry system solutions and services based on decades of applied expertise. AVENTICS is one of the leading suppliers worldwide in the area of industrial pneumatics. The company is a leading technology specialist for pneumatics, for example in the integration of electronics into pneumatics components. With pneumatics solutions for maritime applications and state-of-the-art ship automation systems, AVENTICS has successfully navigated the world’s oceans. The company’s drive and inverted tooth conveyor chains are used in numerous sectors and feature strongly in the glass and automobile industries.

CLEAN RESOURCES

CRP Oil/Water Separators that Work

100% of the time on 100% of compressor lubricants

No Maintenance

Guaranteed to reduce effluent to less than 10 ppm

EPA Compliant



Clean Resources • www.cleanresources.com • 800-566-0402

The company has around 2,100 employees globally, with corporate headquarters in Laatzen, near Hanover (Germany) and production facilities in Laatzen and Gronau/Leine (Germany), Bonneville (France), Eger (Hungary), Lexington (USA) and Changzhou (China). In addition to its production sites, AVENTICS has an extensive sales network and is represented in more than 40 countries around the world.

www.aventics.com/us



PepsiCo Recognizes Motion Industries

Motion Industries, a leading distributor of industrial maintenance, repair, and operation replacement parts, has received a 2013 MRO Supplier of the Year Award from PepsiCo, headquartered in Purchase, NY. Motion was the only company to receive this award in the Other Goods and Services category.

PepsiCo's Supplier of the Year Awards are the most prestigious honor that the company offers to its suppliers, and recognizes outstanding performance at all its primary MRO subsidiaries including Frito-Lay, Gatorade, Pepsi Bottling Co., Tropicana Products, and Quaker Foods.

Motion had exceeded in delivering PepsiCo's key corporate objectives of cost savings productivity, inventory reduction, energy savings and quality, efficiency, and innovation. Motion was specifically cited for implementing a site Cost Savings Blitz, initiating tracking and repair processes, and

identifying significant site savings as a result of an extensive sustainability project.

Mark Thompson, Motion Industries' Senior Vice President Corporate Accounts, stated, "PepsiCo's Supplier Award recognizes the consistently high level of service that we strive to provide at Motion Industries, and it is an honor to earn this landmark award."

With annual sales of \$4.5 billion, Motion Industries is a leading industrial parts distributor of bearings, mechanical power transmission, electrical and industrial automation, hydraulic and industrial hose, hydraulic and pneumatic components, industrial products, safety products, and material handling. Motion Industries has over 550 operations including 15 distribution centers throughout North America and serves more than 150,000 customers from the food and beverage, pulp and paper, iron and steel, chemical, mining and aggregate, petrochemical, automotive, wood and lumber, and pharmaceutical industries.

Motion Industries is a wholly owned subsidiary of Genuine Parts Company (NYSE: GPC). Visit our website at www.motionindustries.com. Contact us toll-free at (800) 526-9328.



To read more [Industry News](#) articles, visit www.airbestpractices.com

Introducing the R1000

Raising the bar for compressor control systems



This easy-to-use, multifaceted system enables plant operators to reduce wasteful energy consumption with the touch of a fingertip.

- Advanced control modes for minimizing waste and increasing energy efficiency
- Instant service notifications to avoid costly downtime
- 9" Full touchscreen display

For more information, please visit www.fs-elliott.com



724.387.3200 fs-elliott.com



Global Energy Management at Corning

By Rod Smith, Compressed Air Best Practices® Magazine

Compressed Air Best Practices® interviewed Patrick Jackson, Director of Global Energy Management.

► **Congratulations on being named a 2014 ENERGY STAR® Partner of the Year by the U.S. Environmental Protection Agency. Why was this award received?**

Thank you. Corning was recognized by ENERGY STAR for adopting a continuous energy management strategy in all of its buildings and plants. Back in 2006, Corning launched a formal Global Energy Management (GEM) program with three focus areas:

1. Ensure reliable energy supply
2. Increase energy productivity
3. Be as “green” as possible

We became an ENERGY STAR® Partner, in 2006, and began using the “ENERGY STAR Guidelines for Energy Management” roadmap. We began the process of adopting the 23 attributes of an energy management program defined

by the ENERGY STAR Facility Energy Management Assessment Matrix. We’ve been working,



over these years, to check off these program attribute boxes. This guidelines document and the assessment matrix provided an excellent road map for us since day one.

This is our first time receiving the award. We were hopeful we would receive it because we thought we achieved 23 out of the 23 attributes



ENERGY STAR official Jean Lupinacci, center, presents the Partner of the Year award to Corning representatives on hand for ceremonies in Washington D.C. on April 29. With her are, (standing from left) David Kubissa, Mike Donnelly, Patrick Jackson, and Scott Ryan; seated are Steve Gattine and Beth Costello.

defined by the guidelines. Additionally, since the program was launched, GEM's management practices have saved Corning more than \$328 million in cumulative energy costs.

Fantastic. Before we go further, what kinds of products does Corning manufacture and where?

Corning Incorporated is the world leader in specialty glass and ceramics. Drawing on more than 160 years of materials science and process engineering knowledge, Corning creates and makes keystone components that enable high-technology systems for consumer electronics, mobile emissions control, telecommunications and life sciences. Our products include glass substrates for LCD televisions, computer monitors and laptops; ceramic substrates and filters for mobile emission control systems; optical fiber, cable, hardware & equipment for telecommunications networks; optical biosensors for drug discovery; and other advanced optics and specialty glass solutions for a number of industries including semiconductor, aerospace, defense, astronomy, and metrology.

Corning is a global company with approximately 34,000 employees worldwide. U.S. operations consist of nearly 50 facilities in 16 states and the District of Columbia

What role does communications play in an energy management program?

Communications play a vital role. We have a great relationship with our corporate communications group.

Communications is tasked with sharing our success stories. Our task is to take processes being learned by employees in one facility and share them with employees in other facilities. This kind of communication allows us to learn from one another. It's an organic process and we've built it into the structure of the corporation. One thing ENERGY STAR® saw is how we've woven energy management into the culture of our company. It's not just a program off to the side.

We have a communications objective where every one of our facilities has a goal to provide two unique stories each year on how they are managing energy. The goal is to share these success stories so other plants can learn from them.

We write stories describing the process in layman's terms and publish them on our internal web site. Also, we send newsletters, and have an intranet site dedicated to the global energy management program. We encourage employees responsible for implementing energy measure to hold training sessions. We also have the Blue Line Internal Social Media platform being used as well. It's all about using all communication tools to share knowledge and promote awareness and action.

How is the Global Energy Management program structured at Corning?

It all starts with the buy-in of the senior leadership at Corning. We have corporate champions and sponsors of the Global Energy Management (GEM) program. When we started the program, two champions were two of the top six officers in our whole



Can You Afford Not To?



CP's Variable Speed Drive compressors can save operating costs when applications don't require a compressor's full capacity. It's great as a stand-alone machine or networked to a base-load CP compressor to function as a trim machine.

**Compressed air that pays for itself...exceed your expectations with CP.
Call 877-861-2722 today.**

People. Passion. Performance.

www.cp.com

© 2014 Chicago Pneumatic. All Rights Reserved.

GLOBAL ENERGY MANAGEMENT AT CORNING

organization. They were there to nourish and recruit new sponsors for various roles. They brought in five sponsors representing engineering, procurement, government affairs, the business service division, and operations/manufacturing. Nine years after launching the program, energy management continues to receive support from the highest levels.

Business services is the division where the program resides today. I am the director of Corning's Global Energy Management. We have an operational manager who is the conduit between me and the businesses. Each business has a divisional energy manager. Within a business, we have site energy managers responsible for an energy team

(a team is more than five people). Energy team members have other jobs and include this responsibility into their roles. Some site energy managers have other full-time positions.

What advice would you offer to Energy Managers starting a program?

I would say realize you can't do it all every day, you need to be systematic, and set some realistic goals for years one and two. Earn initial internal credibility by tackling easily-quantified, low-risk, energy-saving projects like lighting. Build the program in a progressive manner.

Getting senior sponsorship is also critical. This ensures the energy management program

is doing things that corporate leaders want and in this way they can open doors for the program. We've gotten a lot of support from corporate leadership and our management committee.

We believe ENERGY STAR® is the best resource out there to learn how to start an energy management program. We are an excellent example of a company starting from scratch and using ENERGY STAR® to guide us. Betsy Dutrow, director of Energy Star Industrial Partnerships, provided us with the program model and resources. Also, by becoming an Energy Star Partner, one can network and learn from other Energy Managers. When I got into this, I was the business manager for Corning's Business Services Division. I reached out to Betsy and rest is history.

How did you get involved with the energy management program?

As mentioned before, I was the business manager for the business services division, and my third biggest spending area was energy. The top two expenses were salaries and buildings/depreciation/taxes. We thought we could reduce energy spending and created a program just for office buildings. Managing costs is a critical performance metric for strong financial results in any corporation. Any initiative involving methods to strip-out wasted effort, wasted cost, and wasted resources will receive attention from senior management.

When we decided to move forward, we used Six Sigma to develop our process. We did a lot of upfront planning and process management. This was critical in that we didn't want this to just be a series of projects.



The advertisement for FAI FILTRI USA LLC features a collection of various filtration products, including cylindrical filters of different sizes and materials, and a large blue and orange logo. The logo consists of a stylized 'f' and 'i' in blue and orange, with 'filtr' in orange and 'tri' in blue. Below the logo is the text 'A Quality Filtration Company'. The background is a blue sky with white clouds. The text 'The most advanced technology in filtration and separation' is prominently displayed in white on a blue background. At the bottom, the company name 'FAI FILTRI USA LLC' is written in white on a dark blue background, followed by contact information: '9805-M NorthCross Center Court - Huntersville, NC 28078 - Ph. 704-655-1240 - Fax 704-655-1241 e-mail: info@faifiltri.us.com - www.faifiltri.us.com'.

What metrics are used to measure results?

At the corporate level, we measure energy usage per dollar of revenue generated. This is what's called an energy intensity measure. We look at electricity and natural gas separately.

In each division we use a similar fraction. The businesses track energy use and energy cost, and both become a numerator. We then divide the numerator by the units of products produced or the revenues produced by that business. This creates apples to apples comparisons for us to look at.

Creating metrics is an ongoing discussion and we continue to refine them and make them better and more useful. We've had situations where folks have asked us to use different metrics. We evaluate these on a case-by-case basis.

We are proud of the cumulative efforts Corning team members have made. A key metric is the one mentioned before — since its launch, the GEM program has saved Corning more than \$328 million in cumulative energy costs.

What specific energy efficiency projects do you focus on?

We've done so many energy efficiency projects including, but not limited to, compressed air, motors, demand management, metering, and lighting. We believed we should go step-by-step, starting with specific facility projects like lighting. Then, after gaining credibility, we began to tackle process improvements.

Our future steps include going to research & development and examining how to innovate while using less energy. We are also looking at how to take energy out of the value chain

by involving our supplier and our customers. How can we share waste-heat with our clients? Can waste-heat in our factory be used to heat an office building in our community? That's the end state.

How important is compressed air as an energy source?

Compressed air is very important to our manufacturing processes. It's critical we manage it well both in terms of ensuring its reliability as an energy source and from an energy-cost perspective. We know a lot of energy goes into air compressors and we also know that compressed air has a direct impact on our manufacturing processes.

We focus on areas such as air compressor management. We've also worked hard "to maintain the gain" after compressed air system assessments are executed successfully. The different businesses realize compressed air systems require an on-going program to keep the systems at peak reliability and efficiency. We've worked with some of the fitting companies to put the right fittings on the process machines. Some companies offer assistance to review fittings designed to reduce compressed air losses located on pneumatic circuits within the process machinery.

Thank you for your insights and congratulations on Corning being named a 2014 ENERGY STAR[®] Partner of the Year. **BP**

For more information on Corning Inc. visit www.corning.com or for more information on how to become an ENERGY STAR Partner visit www.energystar.gov/about/join-energy-star

To read similar **Energy Manager Profiles** visit www.airbestpractices.com/energy-manager

Sullivan Palatek



SP 20
125 - 300 HP

Electric Driven Industrial Air Compressors

5-10 HP Belt Driven
15-40 HP Direct Drive
40-100 HP Updraft
125-300 HP SP20
300-400 HP SP32

High and Low Pressure
Variable Frequency Drive Designs
Specialty Packaged Systems
Piston Air Compressors

Looking For Distributors
Call 219-874-2497
or 800-438-6203
For Details

Sullivan-Palatek, Inc.
1201 W US Hwy 20
Michigan City, IN 46360
219-874-2497
www.sullivanpalatek.com

DISTRIBUTOR PROFILE: Northwest Pump & Equipment

By Rod Smith, Compressed Air Best Practices® Magazine



Compressed Air Best Practices® interviewed Gregg Miller (President), Stuart Trebelhorn (Vice President Industrial), Brett Cline (Director of Marketing) and Dave Mayfield (Seattle Industrial Sales Manager Compressors) from Northwest Pump & Equipment.

► **Good afternoon. Can you start us off with a little background on your company history?**

Good afternoon. Northwest Pump & Equipment was founded in 1959 — opening three branches on the same day in Portland, Seattle and Spokane. The business focus was to distribute petroleum equipment for the oil and gas market — primarily to service stations and oil jobbers. In-ground fuel tanks, hoists, lubrication equipment, lighting, farm pumps, air compressors and other gas pumping equipment were our primary product lines

back when there were “Full-Service Gas Stations”. Over the years, this successful business model was expanded so the Company did business in California, Hawaii, Washington, Alaska, Arizona, Nevada, Idaho, and Montana.



Northwest Pump & Equipment Operates 16 branches and employs 300 people in the western U.S.

In 1993, we diversified our business by starting an Industrial Division in Oregon, Washington, and Alaska. Our primary product lines are process pumps and blowers serving manufacturing and process industries. We climbed back into the air compressor business in 2010 by taking on the Sullair product line for the Oregon, Washington, Idaho and Montana. In 2013, we agreed to add the five-county Los Angeles area to our Sullair coverage.

Northwest Pump & Equipment today employs 300 people. We operate 17 branches and carry a significant commitment to inventory of products, parts and rental equipment to service our customers. Our philosophy has always been to be a full service company supplying almost all of our customers needs. When we go into a refinery to sell pumps, we may have ten different pump lines, with no overlap, enabling Northwest Pump to solve different challenges for the client.

Your company seems to focus on business fundamentals. Can you elaborate?

Sure. Business doesn't need to be all that complicated. We've found it requires the appropriate investments in people and resources so that customers are taken care of.

Our SolvOne 24-hour call center is an example of these investments. We own and operate this 14-year old Portland-based call center to provide technical support, dispatch service, monitor alarms and handle emergency after-hour phone calls from our clients all across the country. Emergency after-hour phone calls come into this center and are then pushed out to our service technicians on stand-by in the local markets if required. Many issues can be handled right then and there on the phone, be it a technical question or a request for an emergency part shipment.

We do a lot of marketing activities with our customer service representatives. We do cold-calling and email campaigns to support our sales managers. We perform sales blitzes, in specific geographies, by bringing in people from other territories to canvass a target area to find machines we can service. The customer service reps help prepare these sales blitzes by cold calling in advance and setting up appointments.

Please describe your investments in experienced people and in training.

When we took on the Sullair product lines, our first step was to service the existing customer base. The company we replaced put out a lot of equipment so we focused on building our inventory of lubricants and parts and developing our service capabilities.

Most of our service and sales force has been doing this for a long time. Our senior guys have been 30-45 years on the pump side. Our air compressor people have a minimum of



The 24-Hour SolvOne Call Center Based in Portland

It's not a pipe dream....
It's a dream of a piping system!

aircOm
PIPINGSYSTEM

QUICK | EASY | RELIABLE

10-year warranty
100% all aluminum system

www.aircom.us.com

Head Office and Warehouse:
8805-M HardCross Center Court
Huntsville, NC 28078
Ph: 704-887-2088 - Fax: 704-887-2048

West Coast Store:
885 Fenway Drive
Wenatch, CA 91789
Ph: 800-237-8247 - Fax: 909-444-8895

DISTRIBUTOR PROFILE: NORTHWEST PUMP & EQUIPMENT



Air compressor service technician training with Stuart Johns

10 years industry experience. In addition, we work with Stuart Johns and conduct his week-long compressed air system service training programs. His schools are very hard-nosed and very thorough. They are a tough test for the guys — and that prepares them well to take care of our customers.

In the larger markets we have dedicated sales managers for air compressors. We have 8 sales and 13 service personnel dedicated to compressed air systems in the Northwest. In Los Angeles, we have two branches (Anaheim and Glendale) supplying and servicing petroleum equipment. We added two dedicated sales and two dedicated service technicians for compressed air systems to these branches.

In other markets we do extensive cross training so our people can represent pumps, blowers and air compressors. Our people spend a lot of time with Regional Sales Managers from the different vendors training on product and application knowledge.

There are some excellent synergies between pumps, blowers, and air compressors. Pumps get abused and tinkered with and damaged. There are several hundred of them in a plant so you really can develop a strong and deep relationship with their personnel. Air compressors, however, run for years and are very reliable. We find we can leverage our pump relationships quite effectively to grow our air compressor business.

Inventory is an important part of the equation. How do you manage this?

Our philosophy has always been to be a full service provider. In our petroleum equipment division we supply tanks, valves, fittings, dispensers, lighting — everything the customer needs. We do the same in our car wash system division.

NEW!

Compressed intelligence.

Flow, pressure and temperature, three line display, RS485/Modbus, 4..20 mA, USB, and a 2 million point data logger.
All in one instrument!

Now you know where, when, and how much you can save.
Need more information or a quote?
Email us: sales@vpinstruments.com

VPFlowScope® in-line





Measure, manage, improve™

Our industrial division receives the same commitment to inventory. Our strategy is to have a complete product line ranging from high-pressure Sauer compressors to low-pressure blowers and vacuum pumps from Robuschi. For our “normal” industrial plant air applications, we work with Sullair as our main air compressor and dryer vendor complemented by Hitachi oil-free rotary and scroll air compressors and Parker Transair piping systems.

Our industrial parts inventories are centered in Portland, Seattle, Spokane, Pasco (southeast Washington), and Anaheim. The inventories in these hubs are complemented by branch inventories of frequently used parts. We also carry an inventory of roughly 40-50 rotary screw air compressors, ready to ship, out here in the West. We also own a fleet of rental air compressors based in Portland and Seattle. We also stock compressed air filtration products and piping systems.

What’s new with Sullair?

When Sullair approached us about representing them on air compressors we knew it was a top-tier air compressor line. It’s a good quality, stable line that’s been around a long time. They are industry-known for building a bulletproof air end. It’s built in Michigan City, Indiana and it’s so robust. As an ex-mechanic and service guy, that draws me to their rotary screw product line. Another great thing about the Sullair product line is you can have load no-load modulation systems, variable displacement compressors or variable speed drive compressors.

Variable displacement compressors are usually as effective or as efficient as a variable speed drive compressor in the 60-100% operating load range - at a fraction of the cost. To provide a rough example, a 150 horsepower variable displacement machine might cost



Sullair has announced a new 10 year Diamond™ warranty



Together, we can move clean air, guaranteed. From the compressor outlets to the machines with optimal flow, minimal downtime and increased plant productivity.



Transair: Compressed air pipe systems 1/2” to 6”

When you partner with the global leader in compressed air pipe systems, expect to move your business and the world forward. From various fittings to highly integrated pipe systems, Transair’s aluminum pipe ensures higher longevity of equipment and avoids frequent changes of filtration elements. Not to mention, Transair’s energy savings element is critical to lowering your overall cost of ownership. So partner with Parker, and get ready to move clean air, guaranteed.



Scan to see a Transair video.



ENGINEERING YOUR SUCCESS.
www.parkertransair.com ph 480 830 7764

FREE SUBSCRIPTION

DIGITAL EDITION FREE WORLDWIDE | PRINT EDITION FREE TO U.S. SUBSCRIBERS



COMPRESSED AIR BEST PRACTICES

airbestpractices.com

Join Us On The Road To Saving Energy & Improving Productivity In YOUR Industry!

2014 FOCUS INDUSTRIES:

- Beverage Bottling & Packaging
- Grain & Meat Processing
- Pulp & Paper Corrugated
- Chemical, Pharma, Food Bulk Handling
- Energy-Efficiency System Assessments
- Compressed Air System Automation
- Measurement
- Wastewater Treatment
- Food Packaging
- Metal Fabrication & Machining
- Air Compressor Controls

Subscribe at airbestpractices.com

DISTRIBUTOR PROFILE: NORTHWEST PUMP & EQUIPMENT

\$50,000 while a VSD compressor will run \$65,000. That's a big difference in price. Many people have greater faith in electrical components over mechanical devices. Variable displacement is mechanical and does require maintenance, however, the maintenance requirements are reasonable. It's a \$150 kit you put in once every two years plus some labor. At the end of the day, Sullair's product offering allows us to offer the customer all three technologies.

What do you think of Sullair's new 10 year Diamond™ warranty?

We are excited about it and believe we will be able to leverage this new program. This is an example showing how Sullair believes in the distributor and the factory working together. We think this shows The Carlyle Group will be aggressive with new products and innovative approaches to the market. This new Group sounds like they want to expand and get new market share.

Regarding the 10-year Diamond™ warranty, any new Sullair compressor, with operating pressures up to 150 psi, is eligible for the 10 year warranty. It shows the confidence Sullair has in their products. It requires that normal "best practice" maintenance is conducted and recorded including an oil analysis program.

Sullair airends will seemingly last forever if maintenance is done. We have plenty of case studies of airends operating for 20+ years. We have one customer with 150,000 hours — without having to do any airend rebuild work. That machine is still sitting at that plant as a backup machine, ready to go.

Are you involved with compressed air system assessments?

Absolutely. We have invested in Sullair's audit tools and conduct regular audits in all of our markets. Sullair has three levels



Sullair air compressor start-up and check-out at a food processing plant.



Together, we can build it.

For more information on Parker high flow refrigerated and desiccant dryers, email us at fafquotes@parker.com

- Lowest Operating Costs
- Energy Savings with Every Model
- Many Rebate Opportunities
- Build to any Spec
- MADE IN THE USA



ENGINEERING YOUR SUCCESS.

1 855 587 9323
www.parker.com/faf

DISTRIBUTOR PROFILE: NORTHWEST PUMP & EQUIPMENT



“The LogAir™ auditing system can log kW, flow, pressure, dew point, and temperature.”

of audits designed to reduce operating and maintenance costs.

The Sullair SystemWizard™ analysis software allows one to quickly evaluate the cost and efficiency of a compressed air system, compare multiple compressor alternatives, identify opportunities, and calculate investment paybacks on energy saved. Sullair's SysteMate™ solution provides real-time, objective measurements of compressed air usage. SysteMate™ takes power and pressure readings, and accurately calculates

true system flow output and requirements, automatically generating reports that graph system parameters. This entire process can be completed without interrupting production. Lastly, the LogAir™ auditing system can log virtually any parameter in the system, including true power (actual kW measurement), flow, pressure, dew point, and temperature. Based upon a customer's needs and resources, we can use one of these three auditing tools to help them improve their system.

What kind of work are you doing with blowers and vacuum?

This is a good example of synergies within our industrial division. We work with engineering firms and with Pacific Northwest Clean Water Association members with our pump and blower brands. We are using blowers for wastewater treatment plant applications. These are, of course, high-volume low-pressure applications. We work with a lot of clients in the Northwest. We emphasize grit pumps,



Northwest Pump & Equipment services all types of rotating equipment.

vortex pumps and then Robuschi blower systems for the aeration basins.

We talk to customers about actual vacuum demand and the ways to optimize these applications. With “pick and place” and “vacuum hold-down” applications we will compare the pros and cons between a centralized vacuum system and point of use venturis. We will calculate the compressed air flow going into venturis or we have also placed put monitoring equipment (compressed air flow meters) to measure how much compressed air a “pick and place” application is using.

We have also done interesting projects involving the use of vacuum for hold-down on CNC router tables by helping improve performance with more positive “hold down” and less waste by eliminating sheet slippage. Think of it this way,

as more cuts are made more pores are opened requiring more positive “hold down” the more cuts are made. Many people confuse the airflows importance with the vacuum depth. As you draw the wood sheeting down to the table and cut it, what is needed is volume — not pressure. We have started challenging how deep a vacuum is required and found that providing higher air volumes will get the job done. These applications for wood sheeting are performed at less than 9" Hg vacuum but with higher air volume. We might see 6 to 20 of these units in a plant using significant volumes of vacuum (and energy).

We are finding that using a blower in a vacuum application can be a better way to go. Sometimes you can go from a 50 horsepower compressor (designed to provide vacuum), to a 10 horsepower blower (designed to provide

vacuum) with small 67 dba sound-attenuated packages located right at the CNC machine. Working together with Robuschi, we have found you need 3-5 inches of mercury at higher air flows, rather than 28 inches with lower air flows. High airflow at less pressure requires much less horse power, thus lower energy consumption and adding higher profit margins for the customer and as the operation requires less vacuum (negative pressure) the noise dba is drastically reduced as well.

Thank you for your time. BP

For more information on Northwest Pump & Equipment visit www.nwpump.com

To read similar *Profiles* visit www.airbestpractices.com/technology

SPECTROLINE[®] Marksman™ II Ultrasonic Diagnostic Tool

Don't Let Air Leaks Blow Your Budget!



To see the Marksman™ II in action, scan QR code or visit www.spectroline.com

Compressed air and pneumatic leaks aren't just a nuisance. They can significantly increase your plant's operating costs and cause unnecessary compressor wear and tear. That's why we developed the Marksman™ II! This lightweight, hand-held tool provides fast, easy and accurate diagnosis of air leaks. Best of all, it finds these leaks very early on—long before they impact your bottom line!

- Finds compressed air, pneumatic and other pressurized leaks—*quickly and effortlessly!*
- Convenient, easy-to-use touch-control sensitivity pad and power switch
- Internal Noise Control feature and noise-cancelling headphones ensure that tool is unaffected by ambient noise. Ideal for use in noisy environments.
- Precision-engineered hollow air probe helps isolate leaks in cramped areas
- Solid contact probe pinpoints wear or damage to bearings, shafts, pistons and other internal components—*without disassembly!*

The MDE-2000NC Marksman™ II comes complete with ultrasonic receiver, ultrasonic emitter, hollow air probe, solid contact probe, noise-cancelling headphones and rugged carrying case.



SPECTRONICS CORPORATION
ISO 9001:2008 CERTIFIED COMPANY



ENERGY STAR® Sustains Excellence

By Rod Smith, Compressed Air Best Practices® Magazine



Compressed Air Best Practices® interviewed Elizabeth Dutrow, Director, ENERGY STAR Industrial Partnerships.

► **Good morning and thank you for inviting me to attend the 2014 ENERGY STAR Awards.**

Good morning, and you're welcome. I'm glad you were able to attend our ceremony in Washington D.C. As you saw, each year the U.S. Environmental Protection Agency (EPA) honors a select group of organizations that have made outstanding contributions to protecting the environment through superior energy efficiency. These ENERGY STAR Award winners are chosen from a vast network of nearly 16,000 ENERGY STAR partners, and their achievements demonstrate that improving energy efficiency is one of the fastest and most effective ways to fight climate change, save money, and create jobs.

The ENERGY STAR Awards are EPA's highest honors for superior energy efficiency, and several award categories exist. EPA's ENERGY STAR Industrial Partners could receive either *Sustained Excellence* or *Partner of the Year* in the *Energy Management* category. These awards go to organizations for adopting a continuous energy management strategy across the organization's entire portfolio of buildings and plants and for communicating the value of ENERGY STAR and energy management broadly.

We have a lot of readers and even Editorial Board Members from this group. Why did PepsiCo (with CABP Editorial Board Member — Eric Battino) receive the Partner of the Year — Sustained Excellence Award?

We want to recognize companies who sustain their commitment to superior energy management year after year. If you look at PepsiCo for example, they received recognition

for continued commitment to promoting strong energy management practices and the ENERGY STAR program throughout the food and beverage business community. Key 2013 PepsiCo accomplishments include:

- Advancing the energy performance of its operations by four percent. Since 1999, energy intensity has been reduced by 35 percent, equating to savings of \$50 million and 600,000 metric tons of CO2 emissions.
- Realizing a nearly 10 percent improvement in energy efficiency in the beverages division through energy efficiency projects
- Leading by example worldwide in supply chain energy management by



2014 ENERGY STAR INDUSTRIAL ENERGY MANAGEMENT AWARD WINNERS	
Partner of the Year	Corning Inc., Intertape Polymer Group
Partner of the Year - Sustained Excellence	3M, Allergan, CalPortland, Colgate-Palmolive, Eastman Chemical, General Motors, Hanesbrands, Merck, Nissan, PepsiCo, Raytheon, Saint-Gobain, Boeing, Toyota

implementing a global initiative to purchase only ENERGY STAR certified vending machines and product coolers. PepsiCo has improved the energy efficiency of its equipment by 50 percent as compared to models available in 2004, decreasing its energy footprint despite an increase in vending units placed.

Why was Toyota (with CABP Editorial Board Member — Brad Reed) recognized?

Toyota Motor Engineering & Manufacturing (North America) is the manufacturing

headquarters for 15 vehicle, engine, and parts plants across North America. Key 2013 Toyota accomplishments include:

- Reducing energy intensity per vehicle by 1.4 percent. Energy savings since 2002 are valued at \$420 million.
- Meeting EPA's ENERGY STAR Challenge for Industry at six plants, with an average reduction in energy intensity of 18 percent; three plants achieved the 10 percent reduction goal within one year.
- Increasing the number of ENERGY STAR certified

automobile assembly plants in Toyota's portfolio from two to five plants.

- Providing leadership for energy management within the aluminum casting sector by recruiting Toyota suppliers to participate in EPA's ENERGY STAR Focus on Energy Efficiency in Metalcasting, launched in 2013.

Why was CalPortland (with CABP Editorial Board Member — Bill Jerald) recognized?

As you know, CalPortland is a major producer of cement, concrete, aggregates, and asphalt

You Compress Air. We Make Sure It's Dry.

Optimize your compressed air quality with the right dew point instrument.

- ✓ Fastest wet-to-dry response time on the market - just minutes
- ✓ Vaisala DRYCAP® and HUMICAP® sensor technologies ensure accurate, reliable measurements
- ✓ Minimal drift and long 2-year calibration interval
- ✓ Product range from -80°C to +60°C Td with ±2 accuracy
- ✓ High resistance to contamination - immune to compressor oil
- ✓ Complete recovery from saturated conditions

Visit www.vaisala.com/compressedair for more information plus Application Notes, White Papers and more...

 Online Store
store.vaisala.com

www.vaisala.com/compressedair

VAISALA

ENERGY STAR® SUSTAINS EXCELLENCE

ENERGY STAR INDUSTRY FOCUSES: ENERGY PERFORMANCE INDICATORS (EPI) AND ENERGY GUIDES	
Ammonia/nitrogenous fertilizer	Researching*
Cement Manufacturing	Cement Plant EPI
	Energy Guide
Corn Refining	Wet Corn Milling Plant EPI
	Energy Guide
Dairy Processing	Fluid Milk Plant EPI*
	Ice Cream Plant EPI*
	Energy Guide
Food Processing	Juice Processing Plant EPI
	Frozen Fried Potato Plant EPI
	Cookie/Cracker Baking Plant EPI
	Breads & Baked Goods
	Tomato Processing Plant EPI
	Energy Guide
Glass Manufacturing	Flat Glass Manufacturing Plant EPI
	Container Glass Manufacturing Plant EPI
	Energy Guide
Iron and Steel Manufacturing	Integrated Steel Plant EPI*
	Mini-mill EPI*
	Energy Guide
Metalcasting	Aluminum Casting EPI*
	Iron Foundry EPI*
	Investment Steel EPI*
	Carbon/Alloy Steel EPI*
	Energy Guide*
Motor Vehicle Manufacturing	Auto Assembly Plant EPI
	Power Train Plant EPI*
	Energy Guide*
Petrochemical Manufacturing	Petrochemical Plant EPI*
	Energy Guide
Petroleum Refining	Energy Guide
Pharmaceutical Manufacturing	Pharmaceutical Manufacturing Plant EPI
	Energy Guide
Printing	Lithographic Printing Plant EPI*
	Printing Plant Energy Guide*
Pulp & Paper Manufacturing	Pulp Mill EPI
	Integrated Paper and Paperboard Manufacturing Plant EPI
Ready Mix Concrete Manufacturing	Ready Mixed Concrete Plant EPI*
	Energy Guide

in the western U.S. and Canada. CalPortland continues to take energy management to a new level as it celebrates the 10-year anniversary of establishing a formal energy program. Key 2013 CalPortland accomplishments include:

- Reducing energy intensity by nearly 2 percent compared to 2012. Since 2005, cumulative reductions of energy intensity of nearly 14 percent have saved over \$52 million.
- Completing a \$6.2 million gas conditioning tower project at the Mojave Cement Plant, reducing energy consumption by 15.7 million kWh per year and producing annual savings of \$1.25 million.

Please describe your team and the Industrial Partnership.

I have worked for the Environmental Protection Agency (EPA) since college. In that time, I've worked in both regulatory and voluntary programs here. ENERGY STAR is, of course, a voluntary program making its success all the more exciting.

We have a very efficient team of three here that I lead. And, we have some very skilled support including consultants like Fred Schoeneborn, who formerly was the Global Energy Manager for Mobil Oil and created their comprehensive energy management program. We also have Bruce Bremer, who ran Toyota's energy management program until his retirement. The manufacturing plant energy performance benchmarking we do (known as ENERGY STAR plant Energy Performance Indicators) are developed by Gale Boyd at Duke University, while our Energy Guides for helping specific industries find savings opportunities are prepared by Ernst Worrell at the University of Utrecht.

*Under Development

We started the industrial partnerships over a dozen years ago and have engaged well over 740 companies. I emphasize companies and not plants. When you start counting the large number of plants operated by our 740 industrial ENERGY STAR Partners, the energy savings numbers get exciting.

To become an ENERGY STAR partner, the President or Chief Executive Officer of a company submits a Partnership Agreement on company letterhead committing the company to the commonsense actions listed below. It's a simple process with the partner agreement form online at www.energystar.gov/join.

- Measure, track and benchmark energy performance
- Develop and implement a plan to improve energy performance, adopting the ENERGY STAR strategy
- Educate the staff and the public about the partnership and achievements with ENERGY STAR

The action of completing the partnership letter is a unique tool and action that enables a company to engage across all levels and units on energy management to commit to manage energy well.

Please describe ENERGY STAR Certification for Plants

Just like products can earn ENERGY STAR certification, plants can be certified for superior energy performance. We do that by providing an ENERGY STAR plant Energy Performance Indicator (EPI) for evaluating the energy performance of a plant in comparison to its specific industry nationally. For instance, cement plants are scored against cement plants. By putting certain information into the

models a company can get a score from 1 to 100, with average performance at 50 and best performance at 75 and above. To be eligible to earn ENERGY STAR certification, a plant must score at least between 75 and 100, i.e. be within the top quartile of its industry nationally. ENERGY STAR plant EPI's, a unique form of benchmarking, often provide the first look at how a plant is performing within its industry relative to similar plants nationally.

ENERGY STAR Certification is awarded if a plant scores in the top quartile on energy management using the EPI, passes an environmental screen, and has a professional engineer verify the data provided. This is only available for plants where ENERGY STAR EPI's are available for a sector. There is one sector where EPA recognizes the result from a private

system for petroleum refineries, and that is the Solomon Associates EII[®].

We are working with over 29 industrial sectors through our industrial focuses. In 2014 we will begin new industrial focuses for ammonia production/nitrogenous fertilizer and gypsum wallboard plants.

Of these 29 industrial focus sectors, we have developed 27 Energy Performance Indicators (EPI's). Eleven are completed while sixteen are in development with more in planning for this year.

What is the ENERGY STAR Challenge for Industry?

Another energy management tool EPA offers is the ENERGY STAR Challenge for Industry. It



**Your source for industrial
air compressor rentals**



(832) RENT AIR | (832) 934-0300
www.gracoair.com

COPYRIGHT 2014 GRACO AIR LLC. ALL RIGHTS RESERVED. GRACO AIR IS A TRADEMARK OF GRACO AIR LLC AND IS NOT AFFILIATED WITH GRACO® WHICH IS A US REGISTERED TRADEMARK OF GRACO MINNESOTA INC.

ENERGY STAR® SUSTAINS EXCELLENCE

is a basic tool that energy managers can use to build support for energy management at a manufacturing site. Industry uptake of this tool is exciting — over 800 sites are using it! And, several corporations such as General Motors, Hanesbrands, and Colgate-Palmolive even have registered all of their sites worldwide in the ENERGY STAR Challenge for Industry!

We encourage any plant or manufacturing site to take the Challenge. A site expresses its to achieve an energy intensity reduction of 10 percent in five years or less. A plant baseline is developed and registered with us. They don't have to report annually but they do have to track progress and then can report that to us when the site achieves the reduction. The site

is listed as a Challenge Achiever, we send a congratulatory letter to the CEO and the site can celebrate the achievement. There are a few other details on how this is accomplished but they are on the website at www.energystar.gov/industrychallenge along with listings of sites that are taking the Challenge and achieving it. It's a nice tool to set goals and recognize plants that cannot achieve ENERGY STAR plant certification.

How do you recommend a company begin an energy management program guided by ENERGY STAR?

Often companies just perform energy efficiency projects and do not build a comprehensive energy management program.

This results in a cycle of early energy savings followed by increases because energy is not being managed for the long-term. What's missing is a powerful energy management program that spans the company and sustains savings through continuous and comprehensive energy management. The first step is to make a commitment to manage energy across the organization. It's fairly easy to get started with ENERGY STAR. Have upper management sign the ENERGY STAR partner agreement. We help from there with the partnership and guidance that assist companies in moving forward.

The ENERGY STAR Guidelines for Energy Management are the strong backbone of

ENERGY KAIZEN EVENTS

➤ Food Packaging Plant Saves \$70,000 or 1.1 Million kWh per year.

➤ Paper Mill Saves \$207,000 or 4.5 Million kWh per year.



Get your **FREE** Subscription to Compressed Air Best Practices® Magazine to **learn how to save energy.**

Subscribe at

airbestpractices.com

thousands of energy programs in the U.S. This guide contains a step-by-step road map for continuous improvement, based on best practices we've learned along the way from working with the nation's leaders in energy management. This takes effort — but one doesn't have to re-invent a new process. Just follow this proven model.

The Guidelines are broken out into seven main steps. All actions in an energy management program fall within these seven steps. EPA has developed many resources in ENERGY STAR to teach companies how to execute the steps.

- Step 1: Make Commitment
- Step 2: Assess Performance
- Step 3: Set Goals
- Step 4: Create Action Plans
- Step 5: Implement Action Plans
- Step 6: Evaluate Progress
- Step 7: Recognize Achievements

All tools and resources are available free of charge online and are easily accessible from www.energystar.gov/industry.

What are some trends you observe with your ENERGY STAR Partner companies?

Sustainability is an important issue for our partners. We see a growing emphasis on water and solid waste management — in addition to energy management. Many of our partner companies are interested in taking on climate leadership and having carbon dioxide emission goals. We also see more companies are supporting their energy programs with enhanced capital funds. This is because corporate energy management programs have earned the confidence of the finance managers as they have come to recognize the positive return of energy projects.

What lies ahead for the advanced energy management programs?

In 2006, we produced guidance entitled, *Energy Strategy for the Road Ahead*. It's located at www.energystar.gov/energystrategy and discusses how companies should think about energy management as a long-term process moving beyond energy conservation and looking at a company's *energy value chain* — i.e. upstream to suppliers, within the company, and downstream to the product and customer. We have worked through ENERGY STAR to help many of our partners execute

a strategy that goes beyond the basic energy management program. But there is more to do.

It has been exciting to introduce the topic in our focus industries and watch what some have been able to accomplish. For example, I have seen cement companies consider embedded energy in their energy value chain. After building their own solid internal energy programs, many are working upstream to improve energy efficiency in the stone quarries. Then, many of these same companies are looking downstream to work with their customers to help ensure ready mixed concrete operations understand energy management.

We are also pleased to see how the linkages among our ENERGY STAR Industry Focuses are producing results. We started with the Motor Vehicle focus in 2001 and since then we have added the supplier industries of glass, steel, petrochemicals, refining, etc. The interconnections are immense.

Thank you for your insights and congratulations for yet another successful year for ENERGY STAR[®]. BP

For more information on how to become an ENERGY STAR Partner visit www.energystar.gov/about/join-energy-star

To read about *Energy Management Programs* visit www.airbestpractices.com/energy-manager



“Sustainability is an important issue for our partners. We see a growing emphasis on water and solid waste management — in addition to energy management.”

— Elizabeth Dutrow, Director, ENERGY STAR Industrial Partnerships

Evaluating Operational Costs of SANDBLASTING OPERATIONS

By Scott van Ormer, Air Power USA

► Introduction

As you walk past the “sandblasting cabinet” back in the corner of the plant running alone and without the need for monitoring, does the thought of operational costs enter your mind? When it does, are you happy knowing the cabinet is automatic and does not need a full-time operator? Then, did you say to yourself, I wonder how much that abrasive media costs? How long does it last? Is this a more cost competitive alternative? Is there something that might last longer?

These are all great questions and should be evaluated as to their overall impact on your operating costs. What was missed, however, are the two most obvious questions related to operating cost. What type and size nozzles are on this unit and how much compressed air do they use?

CHART 1. ABRASIVE CONSUMPTION PER HOUR AND AIR FLOW IN CUBIC FEET PER MINUTE

	ORIFICE SIZE	PRESSURE AT NOZZLE (PSIG)				
		60	70	80	90	100
(cfm) air	3/16"	30.0	34	38	42	46
(lbs/hr) abrasive		200	230	260	290	320
(cfm) air	1/4"	55	72	78	84	90
(lbs/hr) abrasive		380	420	460	500	540
(cfm) air	5/16"	90	105	120	135	150
(lbs/hr) abrasive		600	675	750	825	900
(cfm) air	3/8"	126	145	163	182	200
(lbs/hr) abrasive		840	945	1050	1155	1260
(cfm) air	7/16"	170	193	215	240	260
(lbs/hr) abrasive		1150	1300	1450	1600	1750
(cfm) air	1/2"	230	260	290	320	350
(lbs/hr) abrasive		1250	1500	1750	2000	2250
(cfm) air	5/8"	360	406	454	500	547
(lbs/hr) abrasive		1950	2340	2730	3125	3520
(cfm) air	3/4"	518	585	652	720	788
(lbs/hr) abrasive		2810	3375	3940	4500	5060



“Nozzle material selection depends on the abrasive chosen, how often you blast, the size of the job, and the rigors of the job site.”

— Scott van Ormer, Air Power USA

Today, most cabinet type units use compressed air to flow the abrasive media (i.e. sand). There was a time in the past when many of these used “slinger type” blasting with paddles that “slung” the media against the object. Today many, if not most of these have been modified (some manual, some automatic) out to compressed air — your most expensive utility.

Before going too far on this, let’s realize that sandblasting is a very complicated topic and often the nozzle choice, operating pressure, and type of media are very critical to the end result of the surface being “blasted”. When this is the case and the blasting is critical to quality and productivity, we have discovered in plant air system reviews that the total package is usually very thorough in thought, well applied, and operating at a reasonable, if not optimum cost.

Sandblasting jobs can go from very small (glass etching) to very large (shipyards). There are many types of blasting media from dry ice to ground up corn cobs, to aluminum oxide to steel shot or grit. They all have a place but the thrust of this article is not on precision sandblasting, but routine sandblasting in plants as part of the production air and ongoing maintenance programs.

Industrial Cabinet Type Abrasive Blasting

Many sandblasting jobs may only consume 1 to 2,000 hours per year, but there may also be

multiple sandblasting cabinets used to prepare parts, de-burr parts, break down a surface, etc. These cabinets may be part of production on the direct product, in a part of the assembly process, or may operate to clean out and resurface molds such as those used in a glass bottling plant.

We see these cabinet blasters in plants all the time and when asking operators, “What type of nozzles do you have”? They answer, “I don’t know”. When we ask how long they run between nozzle changes, this is usually not a time of record. Sometimes we ask, “How do you know when to change nozzles?” Their answer, “Whenever the nozzles break” or “When it doesn’t clean well anymore”.

In a recent audit, this situation came into discussing a blasting box that had twelve, 3/16" ceramic nozzles running at 60 psig. The calculated flow through this process would be 12 nozzles at 30 scfm each moving about 171 lbs/hour of media (see Chart 1 above). The media cost here is not really related to the lbs/hr because most of it is recycled, but the cost of compressed air is directly related to the operating cost. When new, with no leaks, this blaster should use about 360 scfm of compressed air. We installed a flowmeter on the 4" line and found it was actually using about 910 scfm.

To put this in perspective — a \$.06/kWh power rate on an average single-stage, rotary screw, lubricant-cooled compressor (4 cfm

input horsepower at 100 psig) operating 8,000 hours per year will have an electrical energy cost of \$100/scfm/year. Under these conditions, when new, this unit will run utilizing compressed air that costs \$3,600/nozzle/year to produce but now it is costing \$9,100/nozzle/year in electrical energy to produce the same air to do the same job. How does this happen?

Remember those two questions at the beginning of the article? What type and size nozzles are you running? We knew the size of twelve, 3/16" diameter nozzles but the type was ceramic! Do we say congratulations or offer condolences? It will depend on the process.

What are the Best Nozzle Material Choices?

Nozzle material selection depends on the abrasive chosen, how often you blast, the size of the job, and the rigors of the job site. Here are general application guidelines for various materials.

Ceramic nozzles offer good service life at a lower price than other materials offered. They are a good choice in low usage applications where price is a primary factor and nozzle life is less important.

Tungsten carbide nozzles offer long life and economy when rough handling can’t be avoided and mineral and coal slag abrasives are used. All tungsten carbide nozzles are not equal.

EVALUATING OPERATIONAL COSTS OF SANDBLASTING OPERATIONS

SERVICE LIFE COMPARISONS			
APPROXIMATE SERVICE LIFE IN HOURS			
NOZZLE MATERIAL	STEEL SHOT/GRIT	SAND	ALUMINUM OXIDE
Ceramic	200-40	10-30	1-4 (over run)
Tungsten carbide	500-800	300-400	20-40
Silicon carbide composite	500-800	300-400	50-100
Boron carbide	1500-2500	750-1500	200-1000

Silicon carbide composite nozzles offer service life and durability very near tungsten carbide, but these nozzles are only about one-third the weight of tungsten carbide nozzles. Silicon carbide composite nozzles are an excellent choice when operators are on the job for long periods and prefer a lightweight nozzle.

Boron carbide nozzles provide longest life with optimum air and abrasive use. Boron carbide is ideal for aggressive abrasives such as aluminum oxide and selected mineral aggregates. Boron carbide will typically outwear tungsten carbide by five to ten times and silicon carbide by two to three times when aggressive abrasives are used. They are more susceptible to damage from outside forces.

The chart below represents relative service life of four specific nozzles running and three different types of media. There are two very important things to remember regarding nozzle wear:

- At the same pressure as the nozzle wears, it will automatically take and use more air
- At the same pressure as the nozzle wears, the blast pattern breaks up with higher concentration at the center (often a quality problem) and lower

concentration on the outside (a coverage problem) which will often require more time (and more compressed air) to do the job.

In previous blaster cabinet case studies, two nozzles were broken off, all were worn and several holders were leaking. Because there are so many variables, it is sometimes hard to assign a value to the projected effect of proper nozzle type and material and proper monitoring of the process.

An Example Referring to Chart 1

Using aluminum oxide media and a 3/16" ceramic nozzle, we have a rated life that runs from 30 scfm at 60 psig to 90 scfm at 60 psig (5/16") over four hours. Using a straight line average, we would have increased flow 60 more cfm in 4 hours or 15 scfm per hour. The cost to run the increased air demand due to wear on this blaster using the compressed air energy cost shown is \$100/scfm/year = \$1,500/year increase in electrical energy cost per nozzle due to wear.

On the other hand, if running a boron carbide nozzle which lasts 1,000 hours for the same job, we would go from 30 to 90 scfm in 1,000 hours. The average flow increase would be .06/scfm/hour per nozzles or a cost of \$6/year increase in electrical energy cost.



“As in any production process using an expensive utility — compressed air — all steps should be considered to optimize this type of operations and measure the flow to know where you are and when to change.”

— Scott van Ormer, Air Power USA

Total compressed air electrical energy operating cost at \$100/scfm/year

Current air usage when changing ceramic nozzle every 4 hours:

3,000 scfm base flow + 1,500 scfm = 4,500/scfm/nozzle =	\$4,500/year/ nozzles
Total estimated energy cost of 12 nozzles =	\$54,000/year
Total nozzle cost of 2,000 ceramic nozzles per year at \$11.00 each =	\$22,000/year

Proposed usage when changing boron carbide nozzles every 1,000 hours per nozzle:

3,000 + 6 = 3,006/scfm/year/nozzle =	\$3,006/year/ nozzles
Total electrical energy cost of 12 nozzles =	\$36,072/year
Net annual electrical energy cost savings total per cabinet using boron carbide nozzles =	\$17,928/year
Total nozzle cost of 8 boron carbide per year at \$152 each =	\$1,216/year
Savings in nozzle cost =	\$20,784
Total project savings =	\$38,712/year

Comments

- This is a very conservative estimate because the wearing out relationship to air use is not a straight line relationship. The open area of the nozzle goes up with the square of the radius.
- In all probability, the nozzles are not changed every 4 hours as far as the ceramic type is concerned. Compressed air usage will continue on up until the feed and distribution lines become the limiting factor — the air pressure to the nozzles falls and the work done is scrap. At this point we are using significantly more air with poor results and increased time on job and scrap.
- Alumina oxide is a very common blaster media we find in these applications.
- When you operate, you run all the same nozzles, same pressure for all parts or objects. Perhaps it would be appropriate if you find better results with fewer nozzles — lower pressure, etc. each set optimized to the specific job.

Summary

As in any production process using an expensive utility — compressed air — all steps should be considered to optimize this type of operations and measure the flow to know where you are and when to change. That old, outdated blasting cabinet will just keep on running using more and more air unless it is managed. **BP**

For more information contact Scott van Ormer, Air Power USA, tel: 740-862-4112, email: scott@airpowerusainc.com, www.airpowerusainc.com

To read more **Metal Industries** articles, visit www.airbestpractices.com/industries/metals

OPERATING A SPLIT TRIM/BASE SYSTEM

By Ron Marshall for the
Compressed Air Challenge®



▶ Kitchen Craft of Canada is a large kitchen cabinet manufacturer in Winnipeg, Manitoba. They installed a unique compressed air control system where base compressors operate on the low-pressure side of a pressure/flow controller, and trim compressors operate at higher pressure. This arrangement helps keep

operating costs very low and saves significant operating costs over a typical system.

A Growing Company

The facility is very large and supports numerous operations as raw wood comes in and is fashioned into high quality custom

kitchen cabinetry after passing through the various production lines. Kitchen Craft started off in 1972 as a small family owned business producing small quantities of product. As their excellent reputation became widely known, the plant grew quickly in a number of phased expansions. Because there was



Fundamentals of Compressed Air Systems WE (web-edition)

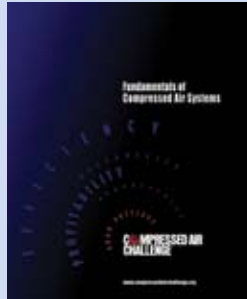

Learn More About System Optimization

Join Compressed Air Challenge for the next session of *Fundamentals of Compressed Air Systems WE* (web-edition) coming soon. Led by our experienced instructors, this web-based version of the popular *Fundamentals of Compressed Air Systems* training uses an interactive format that enables the instructor to diagram examples, give pop quizzes and answer student questions in real time. Participation is limited to 25 students. Please visit www.compressedairchallenge.org, to access online registration and for more information about the training.

If you have additional questions about the new web-based training or other CAC training opportunities, please contact the CAC at info@compressedairchallenge.org

no room in the existing compressor rooms, during each expansion, the required additional air compressors ended up being located in separate sections of the plant in numerous compressor rooms.

A compressed air audit by Manitoba Hydro, the local power utility, revealed that this arrangement was causing lower than desired system efficiency because the compressors were not operating in a coordinated fashion. It was difficult to coordinate the compressor operation due to the distance between compressor rooms and the pressure differentials between each production area. The system specific power was measured at about 30 kW of power consumed for every 100 cfm produced, in the higher range compared to normal in the low 20's. Fortunately, yet another growth spurt opened up an appropriate area in a newly expanded section of the plant for a central compressor room.

Focusing on Efficiency and Sustainability

Kitchen Craft and their parent company MasterBrand Cabinets are concerned

about efficiency and sustainability. They are committed to offering the world's most beautiful cabinetry at a minimum impact on the environment. They do this by keeping

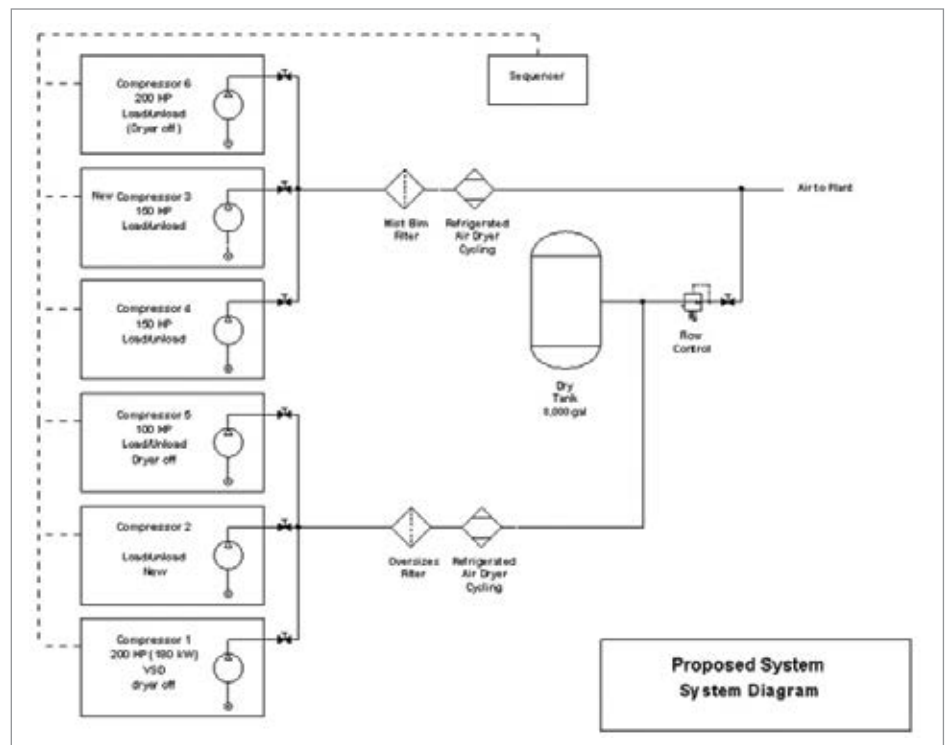

FREE SUBSCRIPTION

DIGITAL EDITION FREE WORLDWIDE | PRINT EDITION FREE TO U.S. SUBSCRIBERS



COMPRESSED AIR BEST PRACTICES[®] airbestpractices.com

Learn How To Save Energy & Improve
Productivity In YOUR Industry!

2014 FOCUS INDUSTRIES:

- Beverage Bottling & Packaging
- Grain & Meat Processing
- Pulp & Paper Corrugated
- Chemical, Pharma, Food Bulk Handling
- Energy-Efficiency System Assessments
- Compressed Air System Automation
- Measurement
- Wastewater Treatment
- Food Packaging
- Metal Fabrication & Machining
- Air Compressor Controls

Subscribe at airbestpractices.com

OPERATING A SPLIT TRIM/BASE SYSTEM

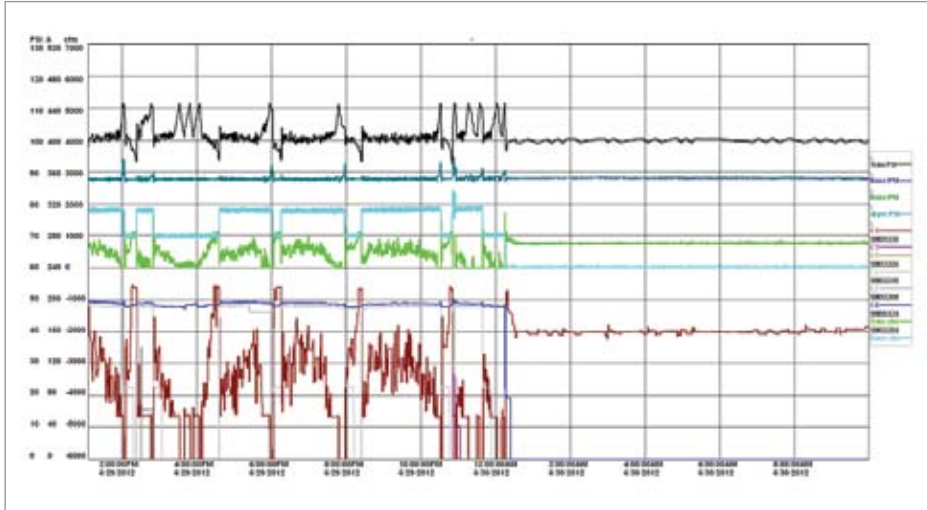

Figure 1: System arrangement uses a split base/trim arrangement

their process simple, fine-tuning the operations and products to be as efficient as possible. As a certified member of the Kitchen Cabinet Manufacturers Association's (KCMA) Environmental Stewardship Program, they demonstrate an ongoing commitment to sustainability. This includes the use of environmentally responsible materials in cabinet products and reduced environmental impact realized through recycling wastes and using low emission coatings. By achieving this certification, the company goes beyond minimum industry requirements and demonstrates leadership in a growing area of concern and importance. As such, once plant

personnel were aware of issues related to their compressed air system, they took action to optimize the efficiency of their compressed air system.

But there were some challenges in upgrading the system; some of the air compressors had higher pressure ratings than others. Some compressors, rated at 125 to 132 psi, were designated as trim compressors, meaning they were units that would take partial loads. Others, units with 100 psi ratings, were deemed suitable for base load duty, where the compressors were run either fully loaded or turned off.

An Electronically-Controlled Pressure/Flow Controller

To gain good compressor control through the use of stored air, the trim compressors were placed on the upstream side of an electronically controlled pressure/flow controller and a large 8,000 gallon storage receiver was installed. This arrangement allowed the trim compressor discharge pressure to operate between two wider set points, with a resulting decrease in compressor load/unload cycles, making the compressors run more efficiently.

The pressure/flow controller was set to 89 psi and the low-pressure compressors connected to the low pressure side through a new thermal mass compressed air dryer and mist eliminator style filtration. Moisture loading in this plant location runs quite low, on average, due to the cooler temperatures and dryer conditions in this region of North America. As a result, the dryer power consumption turns down with lower than rated flows and reduced moisture loading. It is not uncommon to see the dryer kW consumption as low as 10% of full load levels during the coldest winter days. Heat of compression is recovered off all the compressors and a portion redirected into the plant in winter months saving natural gas heating costs.



“Heat of compression is recovered off all the compressors and a portion redirected into the plant in winter months saving natural gas heating costs.”

— Ron Marshall, Compressed Air Challenge®

OPERATING A SPLIT TRIM/BASE SYSTEM

Best Practices for Compressed Air Systems Second Edition



This 325 page manual begins with the considerations for analyzing existing systems or designing new ones, and continues through the compressor supply to the auxiliary equipment and distribution system to the end uses. Learn more about air quality, air dryers and the maintenance aspects of compressed air systems. Learn how to use measurements to audit your own system, calculate the cost of compressed air and even how to interpret utility electric bills. Best practice recommendations for selection, installation, maintenance and operation of all the equipment and components within the compressed air system are in bold font and are easily selected from each section.

To increase system production capacity, a large 200 horsepower variable speed drive (VSD) controlled rotary screw air compressor was added to the trim capacity early on in the various improvement projects. This unit maintains the pressure in the high-pressure side of the pressure/flow controller at a fairly constant higher pressure which stores air in the large storage receiver for later use during high plant demands that exceed the capacity of the running air compressors. Having this VSD unit also reduces wasteful trim compressor unloaded run time. The VSD compressor varies its output by increasing or decreasing the revolutions per minute of the screw element, virtually eliminating times where it is running unloaded, consuming power, but producing no air.

Coordination of Compressor Control

The coordination of the compressor control for this unique system was important to ensure this system is always maintaining constant plant pressure at or slightly above the system set point of 89 psi. Base

compressors must be added or subtracted from the system without causing excessive fluctuations in the pressure downstream of the flow controller. And the number of trim compressors operating at high pressure should be kept to a minimum to ensure more efficient system operation. This lowers the average system discharge pressure and the lower the discharge pressure, the better the system efficiency.

The use of pressure/flow controllers in the manner described is not without controversy. Some compressed air consultants may simply recommend that the complete system be operated at a lower pressure maintaining all the compressor discharge pressures at a lower level. The problem with this type of operation when applied on multiple compressor systems is during the switching of fixed speed compressors in and out of the system during varying loads. Without the pressure/flow controller this switching causes plant pressure fluctuations higher or lower than the system set point whenever base compressors must be added or subtracted. Because

when a compressor is added the pressure must swing low, it is necessary to artificially increase the system pressure target higher to compensate. Since the entire plant system sees this adjustment in pressure, all unregulated uses consume more air, increasing the plant flow artificially and causing higher energy consumption.

The alternative used in this case is to run only the trim compressors at this higher pressure; these are located on the upstream side of the flow controller. The same pressure fluctuations happen at the discharge of the trim compressors during switching of the compressors, however, the plant system does not see the higher pressure because the pressure/flow controller is regulating the pressure to a lower level. This maintains reduces artificial demand, saving compressor power. Because only the running trim compressors are at the higher pressure the average system discharge pressure is kept to lower levels.

This system has run in this manner for over a decade with very good energy consumption levels. Over the years various compressors have been replaced and upgraded as more load had been added to the system due to plant production increases. Whenever compressors are replaced the company has selected units with low specific power, reducing total energy consumption for the system and qualifying for some utility financial incentives. In a recent change the system piping was upgraded to reduce pressure differential and two new compressors were added that use more efficient two-stage compression. Through these changes



“Through these changes the system is able to boast specific power numbers of about 15 kW/100 cfm including air dryers, arguably unheard of levels for air cooled compressed air systems using lubricated screw compressors.”

— Ron Marshall, Compressed Air Challenge[®]

the system is able to boast specific power numbers of about 15 kW/100 cfm including air dryers, arguably unheard of levels for air cooled compressed air systems using lubricated screw compressors. This is far lower than typical numbers seen for similar systems of 20 to 23 kW/100 cfm and a significant 50% reduction from the initial level at the start of the optimization process.

Ongoing Improvements

Kitchen Craft has committed to an ongoing leakage detection and repair program to ensure their system leaks are kept to a minimum. Further to this some significant end use loads, such as compressed air powered agitators, are being targeted for reduction and elimination. Since the compressed air production system has been designed to run very efficiently for all loads, and has excellent turn-down capability, this customer stands to achieve maximum energy savings for any compressed air flow reductions. This is a very important key design characteristic for any system.

As part of the latest improvement project Manitoba Hydro has been able to assist in the installation of a permanent metering system for the compressed air system. This system uses kW meters installed in all the

compressors and air dryer to monitor total power and energy consumption. Thermal mass flow meters also measure system consumption with additional transducers monitoring the pressure. Data is uploaded to cloud storage where performance reports can be generated, including estimated leakage levels, to ensure system savings are maintained.

Summary of Improvements

- Relocated compressors to central compressor room
- Added 8,000 gallons of system storage
- Installed pressure/flow control
- 100 psi base compressors placed on low pressure side of flow control
- 125 psi trim compressors on high pressure side
- VSD compressor purchased
- Compressors tied to specially configured central sequencing controller
- Compressor room piping designed for minimum pressure differential with ring system
- Plant distribution piping upgraded for low pressure differential
- Thermal mass and cycling air dryers installed
- Low differential air filters installed
- Low loss drains purchased
- Heat of compression recovered to displace natural gas heat
- New compressors selected for low specific power (VSD cooling fans, two stage)
- Leakage and wastage program started
- Permanent metering system installed to track flows, pressure and power **BP**

To read more *Air Compressor Technology* articles, visit www.airbestpractices.com/technology

COMPRESSED AIR BEST PRACTICES

airbestpractices.com

FREE SUBSCRIPTION

DIGITAL EDITION FREE WORLDWIDE | PRINT EDITION FREE TO U.S. SUBSCRIBERS



Learn How To Save Energy & Improve
Productivity In YOUR Industry!

Subscribe at airbestpractices.com



RESOURCES FOR ENERGY ENGINEERS

TECHNOLOGY PICKS

Kaeser Launches Redesigned AS Series Compressors

Kaeser Compressors, Inc. is proud to announce the new AS series of belt-drive rotary screw compressors are now available. These units deliver the "built-for-a-lifetime" reliability, simple maintenance, and sustainable energy savings you expect from the Kaeser name and are available in 20, 25, and 30 hp with flows from 64-143 cfm and pressures to 217 psig.



The AS series features a new airend specifically designed to optimize performance and efficiency. The new airend design along with the TEFC premium efficiency motors result in an efficiency advantage over the competition as high as 30%. The enhanced cooling design ensures the overall package is ready for severe operating conditions.

Maintenance accessibility has also been improved. The units' new compact design and two large hinged service doors make it possible to service the unit from one side. The automatic belt tensioning device prolongs belt life and simplifies service, while maintaining optimal drive efficiency. AS models are also available with integrated dryers for premium compressed air quality.

To learn more about the new AS series, visit www.kaesernews.com/AS. To be connected to your local representative for additional information, please call 877-586-2691.

About Kaeser

Kaeser is a leader in reliable, energy efficient compressed air equipment and system design. We offer a complete line of superior quality industrial air compressors as well as dryers, filters, SmartPipe™, master controls, and other system accessories. Kaeser also offers blowers, vacuum pumps, and portable diesel screw compressors. Our national service network provides installation, rentals, maintenance, repair, and system audits. Kaeser is an ENERGY STAR Partner.

New Parker Zero Nitrogen Generators

The Filtration and Separation Division of Parker Hannifin Corporation, the global leader in motion and control technologies, has introduced a new line of Zero Nitrogen Generators designed to transform standard compressed air into a safe, regulated supply of 99.9995% pure nitrogen with <0.1 ppm hydrocarbons.

Nitrogen is produced by utilizing a combination of filtration and pressure swing adsorption (PSA) technologies. Standard compressed air is filtered by high efficiency coalescing filters to remove all contaminants down to 0.01 micron. The air then passes through two columns filled with proprietary carbon molecular sieve (CMS) which adsorb oxygen (O₂) and carbon dioxide (CO₂), moisture, and



RESOURCES FOR ENERGY ENGINEERS

TECHNOLOGY PICKS

hydrocarbons. These are desorbed to atmosphere during the pressure swing cycle leaving a supply of ultra-pure nitrogen.

For ultra-sensitive applications that use electron capture detectors (ECD), units include a heated catalyst module and are specifically designed to replace P5 argon/methane mixtures as well as ultra-high purity nitrogen.

The generators include an economy (ECO) mode which allows the generator to switch into standby mode when there is no demand from the downstream instrument. During this period, the integral compressor stops which reduces the number of running hours and extends the life of the compressor. This significantly reduces the ongoing running costs for replacement compressors, servicing, and downtime. Additionally, the design incorporates advanced noise reduction via the installation and mounting of the compressor and the placement of sound reduction insulation.

Typical applications include gas chromatography (GC) makeup gas and carrier gas, ECD, differential scanning calorimeter (DSC), and any other type of analytical instrumentation requiring a small flow of ultra-high purity zero nitrogen.

For additional information, contact Parker Hannifin Corporation, Filtration and Separation Division, call toll-free at 1-800-343-4048 or 978-858-0505. Parker Hannifin Corporation, 242 Neck Road, Haverhill, MA 01835-0723. www.parker.com/fns/dhlabgasgenerators

About Parker Hannifin

With annual sales of \$13 billion in fiscal year 2013, Parker Hannifin is the world's leading diversified manufacturer of motion and control technologies and systems, providing precision-engineered solutions for a wide variety of mobile, industrial and aerospace markets. The company employs approximately 58,000 people in 49 countries

around the world. Parker has increased its annual dividends paid to shareholders for 57 consecutive fiscal years, among the top five longest-running dividend-increase records in the S&P 500 index. For more information, visit the company's website at www.parker.com or its investor information website at www.phstock.com.

Teseo Introduces New AP36 Diameter Piping

TESEO is introducing the new AP36 diameter for the AP range of compressed air distribution piping. The new profile adds to the AP range, filling the gap between AP28 and AP45 diameters. AP36 offers lighter weight and quicker assembling compared to the D32 profile of the HBS line, featuring all the benefits of the new AP range: with its unique design and wide range of accessories, AP speeds up installation and plant modifications, also on complete installations.

It can be installed using standard tooling, with few easy and safe operations, without any threading, welding or painting. All four profile faces can carry outlet plates or anchors. The new-generation joints have also been

enhanced with a reduction of locking screws, which translates into significant installation time reduction. Also the new AP36 profile can be curved to make curves at 45 and 90 degrees or any required angle and shape.

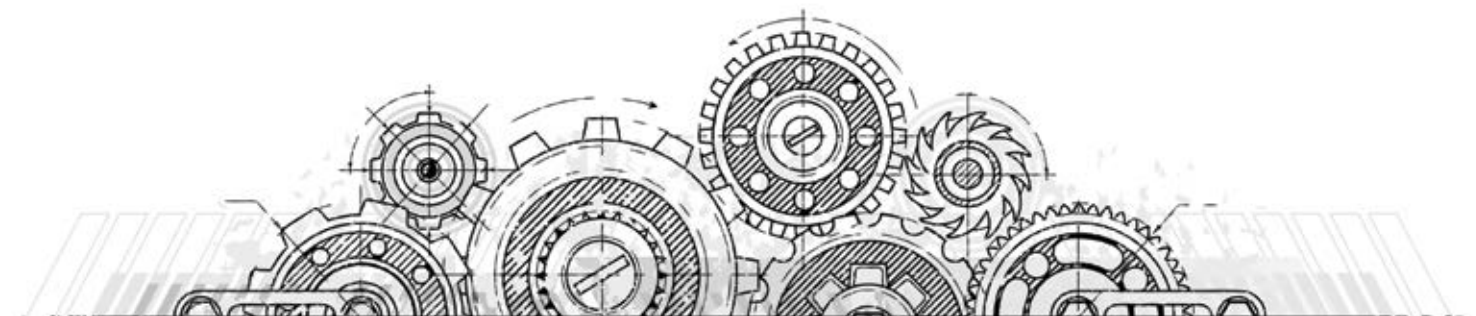

TECHNOLOGY PICKS

TESEO is also presenting **new accessories for the HBS110 profile**: cross joint, 45°-coupling and flanged terminal. New accessories are designed to streamline installation work, providing solutions that simplify and speed up installation and modification procedures on distribution systems for compressed air and other non-hazardous fluids under pressure.

Visit www.teseoair.com for more information

About TESEO srl

Teseo srl was founded in 1988 and immediately emerged as a pioneering, innovative and creative company. In the early '90s, Teseo was the first company worldwide to develop a modular system of aluminum profiles for the distribution of compressed air. Today, these systems have set a reference at international level for fluid power distribution such as compressed air and vacuum, both in small handicraft workshops and the big industry. Teseo is a dynamic and constantly developing company, both in terms of market presence and for its capacity to offer innovative, leading-edge solutions, as a result of the constant commitment and work by the internal R&D laboratory. With this approach, the modular piping by Teseo, the first and the original in its category, has been constantly developed, enhanced and modernized for two decades.

The modular piping systems by Teseo are installed in the most different fields, with prestigious references in the automotive, textile, mechanical and automation industries. Besides the Italian headquarters in Desenzano del Garda, Teseo srl has five subsidiaries: Teseo Iberica, Teseo Nederland, Teseo UK, Teseo Deutschland and the new North American branch office Teseo Canada.

New BOGE Range of Nitrogen Generators

BOGE will be launching a new range of nitrogen generators early in 2014. With these new generators, BOGE will be able to provide a complete system for generating nitrogen, making users self-sufficient and guaranteeing a reliable and demand-dependant supply.

Nitrogen is used in a variety of industries, including the oil and gas industry and in laser cutting, for increasing the shelf life of food and for fire and explosion prevention. When it comes to sourcing a nitrogen supply, companies are faced with the choice of producing their own nitrogen or taking out a contract with an outside supplier. In this case, the nitrogen is delivered either as a gas in bottles and bundles, or in a liquefied state in dewars or tanks, depending on the quantity required. On the other hand, there are obvious advantages to producing nitrogen inhouse: users get just the purity, output and delivery flow which their specific processes call for. Depending on the particular use, this can often be significantly cheaper than having it delivered by a gas supplier.

Producing your own nitrogen also provides great independence and a supply guarantee which can scarcely be provided by an outside gas supplier. By doing away with liquid gas tanks on the factory premises, companies not only free up space but also save considerable expense,



RESOURCES FOR ENERGY ENGINEERS

TECHNOLOGY PICKS

since storing gas is subject to strict safety regulations. Generators for in-house nitrogen production, however, pay for themselves within less than three years, depending on the purity of the nitrogen required. In addition, companies can continuously monitor not only the purity, thanks to the oxygen analyzer sensor, but also the nitrogen quantity generated, using a flow sensor.

All-round solution for nitrogen generation BOGE is a system provider who offers users a closely tailored complete package for generating nitrogen. The centrepiece of this all-round solution is the nitrogen generator selected from the N 7 P to N 56 P range. Closely tailored to the nitrogen demand, it delivers purity grades of up to 5.0 (99.999%). Besides the nitrogen generator itself, complete with system vessels and receivers, to generate nitrogen users also require a compressed air station made up of a compressor, refrigerant dryer, filtration, activated carbon adsorber and a compressed air receiver. If the company already has a compressed air station, the generators can simply be connected to the existing network. To produce nitrogen, the generators need a supply of class 141 purified compressed air according to ISO 8573-1 (including activated carbon adsorber). The quantity of compressed air depends on the nitrogen purity required.

Flexible design with continuous quality surveillance Thanks to its modular design, it is easy to expand or retrofit the generator on site. Up to two expansion banks can be connected to each master bank. Each bank, in turn, takes up to eight discrete easy-to-fit modules. The up to 24 modules that result provide flexible nitrogen generation of between 1.3 and 265.8 Nm³/h. By combining even more of the complete systems, output can be increased to meet even higher demand. Since only the valves of BOGE nitrogen generators need to be inspected periodically, the units are virtually maintenance-free and do not incur any additional expense.

Up to two additional banks can be centrally controlled by the master bank controller. BOGE nitrogen generators are fitted with a basic control as standard supply. This can display two readings, such as the purity of the nitrogen and the quantity of nitrogen generated. The generator can be rounded off with an optional microprocessor or touchscreen control to enable additional readings to be displayed.

Adsorption technology for maximum efficiency and reliability BOGE generators use the pressure swing adsorption (PSA) process to produce nitrogen. During this process, purified compressed air flows through a vessel containing a carbon molecular sieve (CMS), and the oxygen molecules in the air are adsorbed while they pass through. This adsorption process continues until the CMS is saturated with oxygen molecules. The other vessel is now used, while the saturated vessel regenerates itself, and the regeneration gas is vented into the ambient air. The same process takes place in every single module. The resulting nitrogen obtained is then fed into a receiver.

About BOGE Compressors

BOGE America is the United States of America Daughter Company of BOGE KOMPRESSOREN Otto Boge GmbH & Co. KG based in Bielefeld, Germany. BOGE manufactures a comprehensive range of oil lubricated and oil free screw and piston compressors used by all sectors of industry to supply compressed air for a wide range of manufacturing processes. It also supplies a complementary range of filters, dryers and condensate management equipment. The product is sold and serviced through a dedicated network of over 50 distributors in North and South America.

Contact Scott Woodward, General Manager

E-mail: s.woodward@boge.com

Tel: +1 770 874-1570

Fax: +1 770 874-1571

www.boge.com/us



TECHNOLOGY PICKS

Michell Instruments Gains IECEx Certifications

Michell Instruments has recently gained IECEx certification for its hazardous area certified range of moisture, hydrocarbon dew-point, oxygen and binary gas analyzers. Adding this certification to the range means the analyzers now have approvals for installation in hazardous areas around the world.

The complete set of approvals for the Exd range now include:

- IECEx — globally accepted and required by Australia and South Korea
- ATEX — required in Europe
- CSA — harmonized certification applicable in both USA and Canada
- TC-TR Ex — required in the CIS zone (Russia, Kazakhstan and Belarus)
- Ukraine EX — required in Ukraine

Michell also has experience delivering complete analyzer systems conforming to Brazilian hazardous area certification, INMETRO.

The new certifications apply to Michell's Condumax II Hydrocarbon Dew-Point Analyzer, Promet EExd moisture in process gases analyzer, Liquidew EExd, which analyses moisture in petrochemical liquids, the XTP601 oxygen analyzer and the XTC601 binary gas analyzer. This means that all Michell moisture, oxygen and hydrocarbon dew point applications, around the world can be covered by these analyzers.

Michell offer the world's largest range of moisture and hydrocarbon dew point analyzers for the oil, natural gas, refining and power industries. As well as Exd certified analyzers, Michell also offer

intrinsically safe options for measuring moisture on-line in liquids and gases — the Promet I.S. and the Liquidew I.S. For spot checks of moisture in process gases, the MDM300 I.S. is a compact and practical option for high-speed measurements.

About Michell Instruments

Michell Instruments Group is a worldwide leader in the field of moisture and humidity measurement solutions. With over four decades experience, Michell designs and manufactures a wide range of sensors, instruments and customized systems capable of measuring dew-point, humidity and oxygen in applications and industries as diverse as compressed air, power generation, petrochemical, oil and gas, food processing and pharmaceutical. Michell's innovative products make processes cheaper, cleaner, more energy efficient and safe.

The Group has multiple manufacturing locations with their international headquarters located in Ely, UK and a North America sales and service headquarters located in Rowley, MA. It has its own facilities in 10 countries with an extensive network of factory trained application and service engineers, subsidiaries and distributors stretching across 56 countries. Visit www.michell.com

New ABB Micro Drive

Designed to set new benchmarks in ease of use for simple machine control, the ACS250 is designed to meet the production and performance needs of system integrators, original equipment manufacturers (OEMs) and panel builders, as well as the requirements of end users in a broad range of applications — from augers, mixers, pumps, and fans, to conveyors.

COMPRESSED AIR BEST PRACTICES

airbestpractices.com

FREE SUBSCRIPTION

DIGITAL EDITION FREE WORLDWIDE | PRINT EDITION FREE TO U.S. SUBSCRIBERS



2014 FOCUS INDUSTRIES!

Beverage Bottling & Packaging • Grain & Meat Processing • Pulp & Paper Corrugated • Chemical, Pharma, Food Bulk Handling • Energy-Efficiency System Assessments
Compressed Air System Automation • Measurement • Wastewater Treatment • Food Packaging • Metal Fabrication & Machining • Air Compressor Controls

Sustainable Energy Savings with Compressed Air Best Practices®

"Compressed air is the #1 kW user across our 35 factories."

– Doug Barndt, Manager Demand-Side Energy & Sustainability, Ball Corporation

Compressed Air Best Practices® is a technical magazine dedicated to discovering **Energy Savings** in compressed air systems — estimated by the U.S. Department of Energy to represent 30% of industrial energy use. Each edition outlines **Best Practice System Assessments** for industrial compressed air users — particularly those **managing energy costs in multi-factory companies**.

"Do your homework, demand excellence, and don't be afraid to say no to the audit. If you want to audit my plant, you should be able to provide some savings incentive beforehand."

– Rodney Dayson, Sustainability & Energy Manager, Archer Daniels Midland BioProducts.
Article published in the Jan/Feb 2013 Edition of Compressed Air Best Practices® detailing a compressed air energy-savings audit saving \$422,000 annually at ADM.

"Demand Side" and "Supply Side" information on compressed air technologies and system assessments is delivered to readers to help them save energy. For this reason, we feature Best Practice articles on when/how to correctly apply **air compressor, air treatment, measurement and control, pneumatic, blower and vacuum technology**.

Industrial energy managers, utility incentive program managers, and technology/system assessment providers are the three stakeholders in creating energy efficiency projects. Representatives of these readership groups guide our editorial content. The Compressed Air Best Practices® Editorial Advisory Board guides our mission to help create more energy saving projects.

To subscribe visit **airbestpractices.com**

RESOURCES FOR ENERGY ENGINEERS

TECHNOLOGY PICKS

The drive offers two degrees of environmental protection, starting with the standard IP20 panel-mounted chassis. For more demanding environmental conditions, such wash-down applications that require on-machine mounting, the IP66/UL Type 4x drive is the perfect solution.

With its feed-thru wiring, the IP20 chassis drive easily can replace motor starters, to improve overall energy efficiency, reduce mechanical stresses and enhance the process control of many applications. The drive's compact and uniform dimensions facilitate multiple drive solutions and cabinet installations, saving valuable installation space.

The IP66/NEMA 4X drive was designed with materials that meet stringent hygiene standards, preventing the drive from trapping bacteria, and allowing the drive to thrive in harsh environments that contain dust, moisture and chemicals. The integrated keypad provides straightforward drive commissioning and maintenance, and the sealed ABS enclosure and corrosion-resistant heat sink are ideal for wash-down applications.

The drive supports precise process control, with an enhanced V/Hz control with variable-torque or constant-torque V/Hz profiles, and embedded Modbus-RTU communication interface for real-time control and monitoring.

The IP20 drive is available in 1~115 V In / 3~230 V out and 600 V In/Out, completing ABB's micro drives portfolio. The IP66/NEMA 4X

drive offers one of the broadest voltage ranges in the micro drives class — from 1~115V In/3~230V Out, to 600V In/Out — covering all the typical global voltage requirements of machine builders with a single family of machinery drive.



About ABB

ABB (www.abb.com) is a leader in power and automation technologies that enable utility and industry customers to improve performance while lowering environmental impact. The ABB Group of companies operates in around 100 countries and employs about 145,000 people.

COMPRESSED AIR BEST PRACTICES® www.airbestpractices.com

Advertising & Editorial
Rod Smith
rod@airbestpractices.com
Tel: 412-980-9901

Subscriptions & Administration
Patricia Smith
patricia@airbestpractices.com
Tel: 412-980-9902

A Publication of: **Smith Onandia Communications LLC**
217 Deer Meadow Drive
Pittsburgh, PA 15241

Compressed Air Best Practices® is published monthly by Smith Onandia Communications LLC., 217 Deer Meadow Drive, Pittsburgh, PA 15241. Phone 412-980-9902, email patricia@airbestpractices.com. Compressed Air Best Practices® is a trademark of Smith Onandia Communications, LLC. Publisher cannot be held liable for non-delivery due to circumstances beyond its control. No refunds. Standard postage is paid at 100 W. Main Street, Senatobia, MS 38668. POSTMASTER: Send address changes to Compressed Air Best Practices®, 217 Deer Meadow Drive, Pittsburgh, PA 15241. SUBSCRIPTIONS: Qualified reader subscriptions are accepted from compressed air professionals, plant managers, plant engineers, service and maintenance managers, operations managers, auditors, and energy engineers in manufacturing plants and engineering/consulting firms in the U.S. To apply for qualified reader subscriptions, please fill in the reader response cards herein and mail or fax or go to www.airbestpractices.com. To non-qualified subscribers subscriptions are \$65 in Canada and \$95 for other countries. When available, extra copies of back issues are \$4 plus shipping. Contact Patricia Smith for subscription information at Tel: 412-980-9902 or email: patricia@airbestpractices.com. REPRINTS: Reprints are available on a custom basis, contact Patricia Smith for a price quotation at Tel: 412-980-9902 or email: patricia@airbestpractices.com. All rights are reserved. The contents of this publication may not be reproduced in whole or in part without consent of Smith Onandia Communications LLC. Smith Onandia Communications LLC. does not assume and hereby disclaims any liability to any person for any loss or damage caused by errors or omissions in the material contained herein, regardless of whether such errors result from negligence, accident, or any other cause whatsoever. Printed in the U.S.A.

THE MARKETPLACE

JOBS



RENTALS GENERAL MANAGER

Responsibilities:

- Developing and maintaining relationships with customers.
- Visiting with Clients and potential Clients to promote rentals.
- Establishing new rental sales accounts.
- Supervising and motivating rentals sales representatives.
- Marketing efforts and promoting company rental equipment.

Requirements:

- Bachelor's degree or equivalent.
- Experience in Machinery Rentals in all industries including oil & gas industry.
- Excellent Negotiation and closing Skills.
- Excellent communication Skills.
- Sense of urgency.

Please submit resumes to erika@gracoair.com

Visit www.gracoair.com to learn more about our company!

Job & Product Marketplace Advertising Information

Reach 13,000+ readers of Compressed Air Best Practices® Magazine with Marketplace Ads every month! Job Marketplace ads are also placed for one month on www.airbestpractices.com and promoted in our three monthly e-newsletters.

Ad dimensions are 2.36" wide x 3.91" tall. We can help you design the ads. Send us your logo, product photo, and text to anna@airbestpractices.com. We recommend 20-50 total words of text.

Prices are \$300.00 per Job Marketplace Ad and \$350.00 per Product Marketplace Ad (\$300 if 6 or more ads are placed). Contact Rod Smith at rod@airbestpractices.com to schedule your Marketplace Ads.



COMPRESSED AIR EQUIPMENT SERVICE TECHNICIANS NEEDED!

Fluid-Aire Dynamics is an independent, rapidly growing, 30 year old compressed air solutions company who is looking to add to our team! We are searching for talented and experienced field service technicians to join our Elite Service Team. We have multiple openings in Chicago (Franklin Park, IL & Schaumburg, IL) and San Antonio, TX locations.

Applicants should be experienced with all major types of air compressors and dryers. Training and certification is available for

refrigeration systems if required. 5+ years of experience is preferred, but we are open to hear from anyone who is looking to advance their career. Our current team has over 125 years of combined experience to assist in training. More important than experience is applicants who are customer focused and that are team players.

Salaries and incentive packages vary depending on experience and qualifications. Benefits include Health, Dental and Vision Insurance.

For San Antonio Location Please Contact Brad Walker | email: brad.walker@fluidairedynamics.com | phone: (210) 849-5998
For Chicago Location Please Contact Ed Diener | email: ed.diener@fluidairedynamics.com | phone: (847) 678-8388 x 294

For more information about Fluid-Air Dynamics, please visit us on the web at <http://fluidairedynamics.com/>

TECHNOLOGY



Compressed Air Leak Management System

- Automatic reporting to management
- Cloud based mobile application
- Knowledge database of compressed air savings
- Paperless solution
- Energy savings up to 50%!



WORLDWIDE PARTNERS WANTED!

Contact us at: partners@calms.com
DON'T MISS OUT ON YOUR OPPORTUNITY.

www.calms.com

FREE SUBSCRIPTION
DIGITAL EDITION FREE WORLDWIDE
PRINT EDITION FREE TO U.S. SUBSCRIBERS



COMPRESSED AIR
BEST PRACTICES

Subscribe at airbestpractices.com

COMPRESSED AIR BEST PRACTICES®
www.airbestpractices.com

ADVERTISER INDEX

Company	Page	Web Site
Kaeser Compressors	Outside Back Cover	www.kaeser.com/CABP
Association of Energy Engineers	Inside Back Cover	www.energycongress.com
Atlas Copco	Inside Front Cover	www.atlascopco.us
Hitachi	3	www.hitachi-america.us/oil-free-compressors/
BEKO Technologies	7	www.bekousa.com
Nano Purification Solutions	8	www.n-psi.com
JORC Industrial	9	www.jorc.com
Clean Resources	10	www.cleanresources.com
FS Elliott	11	www.fs-elliott.com
Chicago Pneumatic	13	www.cp.com
Fai Filtri	14	www.faiiltri.us.com
Palatek Compressors	15	www.sullivanpalatek.com
Aircom	17	www.aircom.us.com
VP Instruments	18	www.vpinstruments.com
Parker Transair	19	www.parkertransair.com
Parker FAF	21	www.parker.com/faf
Spectronics	23	www.spectroline.com
Vaisala	25	www.vaisala.com/compressedair
Graco	27	www.gracoair.com

THE MARKETPLACE

TECHNOLOGY



Cooling, conditioning, purifying.

MTA-USA...“one stop” shopping for all your compressed air treatment products and process chiller systems!



MTA USA, LLC

25 John Glenn Drive, Suite 104
Amherst, New York 14228 USA

Tel: +1 716 693 8651 • Fax: +1 716 693 8654
www.mta-it.com • info@mta-it.com

IPAC



Air Cooled AfterCoolers

The IPAC Advantage

- Compact
- Heavy Duty Industrial Grade Construction
- Rigid and Durable Air in/out Connections
- Flex Connections Unnecessary
- Available TEFC Motors
- Low Energy Cost
- Meets All OSHA Requirements

Product Options

- Air Motors With Mufflers
- Low Ambient Control Packages
- Special Coatings (i.e. Corrosion Resistant)
- Alternate Materials- Tube, Fin, or Housing
- Custom Designs Available

IPAC, INC.

155 Pineview Dr. Amherst, New York 14228
1-800-388-3211 | www.ipacinc.com

"Your Compressed Air Treatment Specialists"
E-Mail: mpryzak@ipacinc.com

High Efficiency Compressor Controllers

Control Rotary Screw, Vane, Scroll or Recip Compressors



Save Energy controlling up to FOUR compressors and qualify for **Utility Rebates.**

- Automatic Lead/Lag Control-up to FOUR Compressors

Accurate Pressure Control with Pressure Transducers

Compressors and Vacuum Pumps from 1 to 250 hp

Thousands of Installations Worldwide. Call for Application Engineering.

Standard Pneumatic Products, Inc.

Tel: 203-270-1400 • Toll free: 800-979-9156

Email: sales@stdpneumatics.com

www.stdpneumatics.com



SPVG

SAMUEL Pressure Vessel Group

- Stock Tanks - 12 to 5000 Gallon Available
- Custom Tanks - Up to 60,000 gallons
- Special Finishes - Galvanized / Epoxy Lined / Powder Coat & Special Paint Available
- High Pressure - Tanks Available up to 5,000 PSI
- Special Codes - CE / PED, Canadian CRN, China Code, ABS - Coast Guard, NR-13, DOT, SAE-J10 and MORE
- Great Logistics - FOB: Virginia, Wisconsin or Ontario, Canada



Call: (800) 247-8265

www.samuelpressurevesselgroup.com



Modular Piping for Compressed Air, Nitrogen and Vacuum

Heavy-Duty 100% Aluminum Pipe & Fittings



Master Distributors

Midwest: www.pneutechproducts.com

East Coast: www.titusco.com

Seeking Master Distributors in Uncovered Regions in the Americas
Contact Paolo Nardi: sales@teseoair.com,
www.teseoair.com

EnergAir's innovative SCADAR product makes compressed air auditing easy!

Produce compressed air audits using flexible hardware with cloud software that's dedicated to compressed air.



- ✓ Chart & Graph in an instant!
- ✓ Simulate energy, cost & carbon savings at the touch of a button
- ✓ Visit our micro site at www.scadar.eu to find out more about SCADAR



+1 855 289 9317

www.energair.com

nicolas.dedeken@energair.com

2014
WEEC
World Energy
Engineering
Congress



OCTOBER 1-3, 2014
WASHINGTON CONVENTION CENTER
WASHINGTON, DC

FREE Expo Pass
www.energycongress.com/FreeExpoPass

Be a part of 2014's biggest energy event...

The WEEC Expo and Conference explores the complete spectrum of energy, power, building systems, and facilities technologies & services.

ENERGY EFFICIENCY AND ENERGY MANAGEMENT • RENEWABLE, GREEN AND ALTERNATIVE ENERGY • LIGHTING EFFICIENCY
HVAC SYSTEMS AND CONTROLS • COMBINED HEAT & POWER / COGENERATION / DISTRIBUTED GENERATION • GEOEXCHANGE TECHNOLOGIES
SMART GRID AND ELECTRIC METERING INNOVATIONS • BOILERS AND COMBUSTION CONTROLS • THERMAL STORAGE AND LOAD MANAGEMENT
INTEGRATED BUILDING AUTOMATION & ENERGY MANAGEMENT • SOLAR AND FUEL CELL TECHNOLOGIES
ENERGY SERVICES, ENERGY PROCUREMENT AND PROJECT FINANCING • APPLICATIONS SPECIFIC TO FEDERAL ENERGY MANAGEMENT PROGRAMS



Save \$200 on conference registration, coupon code WEEC14PA
www.energycongress.com

kaeser.com

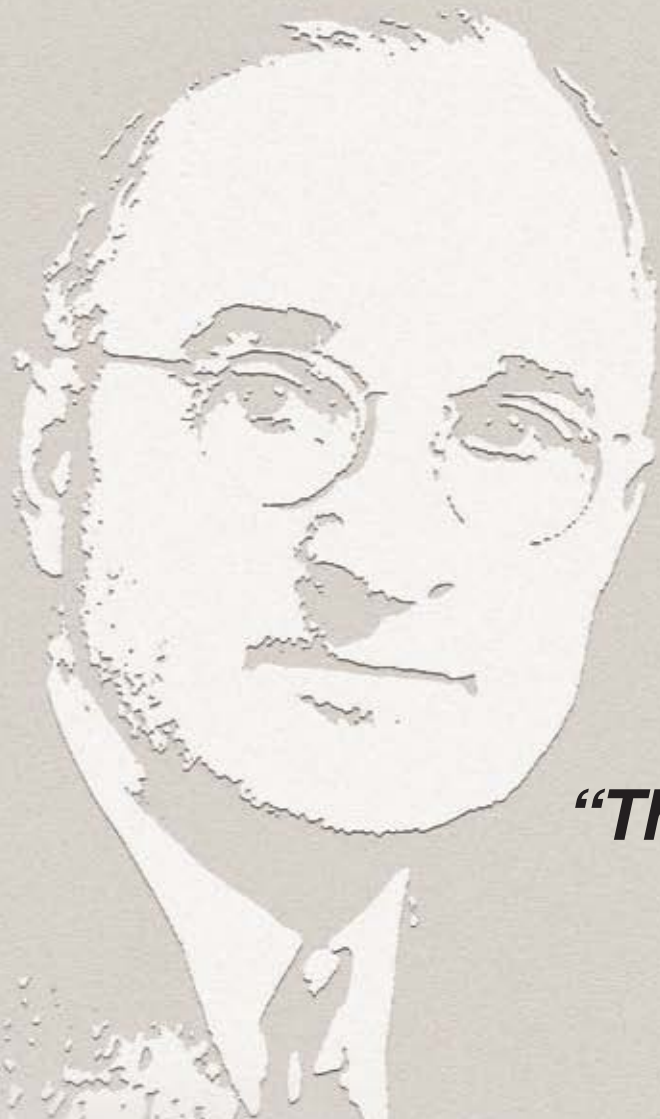

**KAESER
COMPRESSORS**

Built for a lifetime.™

“The buck stops here.”

— Harry S. Truman

**When it comes to service,
Kaeser doesn't pass the buck.**

Everyone appreciates a company that stands behind its products – no matter what. That's Kaeser.

We don't just sell equipment. We help you design your system, install it, and service it. We can even monitor it for you. Our goals are the same as yours: **efficient compressed air systems you can rely on.**

Innovative technology ... ultra-reliable products ... outstanding service. It's no wonder Kaeser delivers the best value for the price! Contact us today to learn more about the powerful benefits of owning a Kaeser compressed air system.



Kaeser Compressors, Inc. • 866-516-6888 • kaeser.com/CABP

Built for a lifetime is a trademark of Kaeser Compressors, Inc. ©2014 Kaeser Compressors, Inc. customer.us@kaeser.com

Certified Management Systems

