

November 2011

## COMPRESSED AIR

# BEST PRACTICES<sup>®</sup>

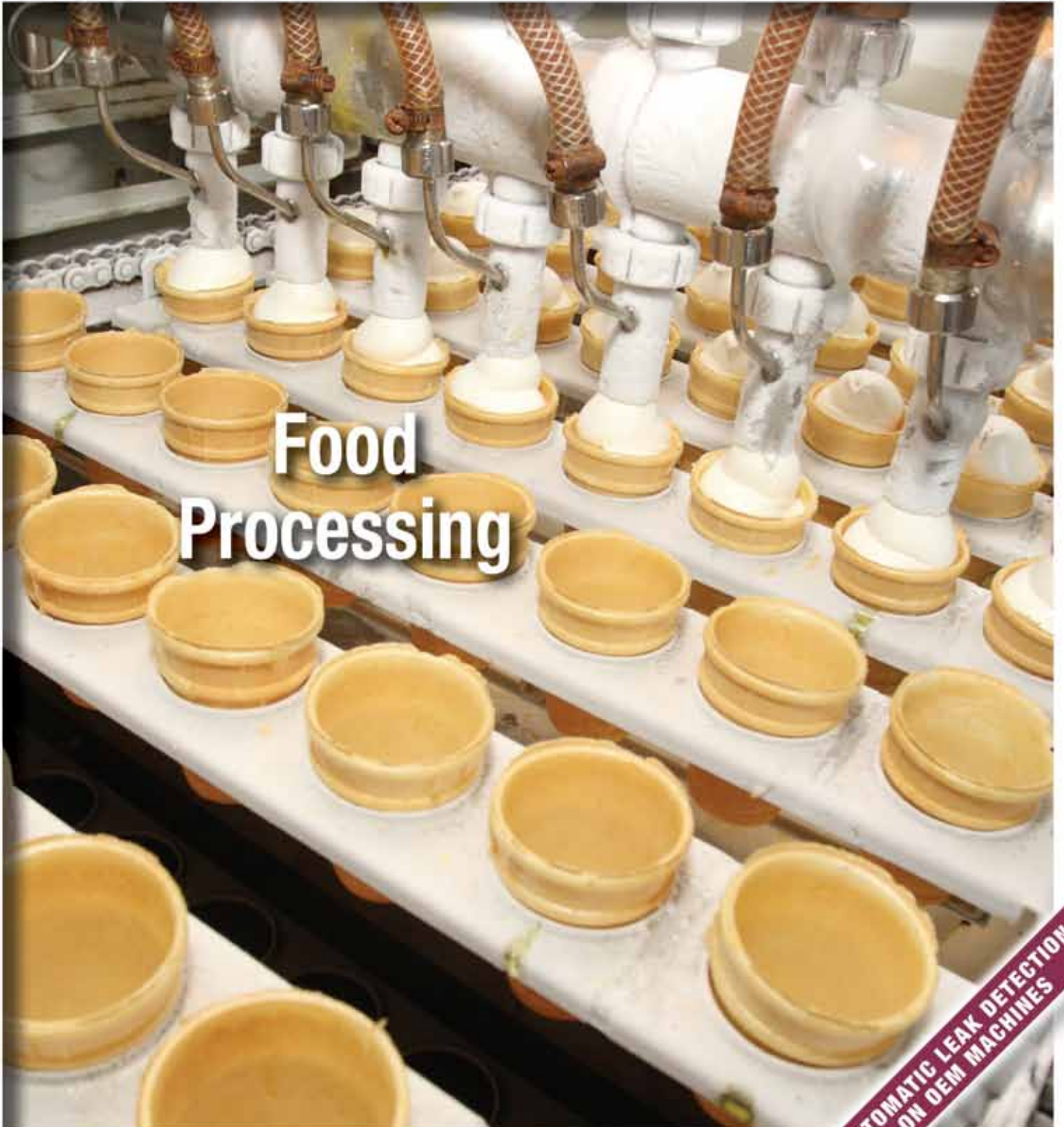

**Food  
Processing**

**AUTOMATIC LEAK DETECTION  
ON OEM MACHINES**

# Keeping your production on track



Hi, I'm Daniel and I've been a service technician working with Atlas Copco products for over 26 years. I've seen technology race ahead over that time, but the one thing always setting the pace is our commitment to keep your productivity on track.

The key behind Atlas Copco's service offering is that it's fully customizable, with a selection of plans and programs that put **you** in the driver's seat. We understand how important compressed air is within your workplace and keeping your production fine tuned is our number one priority. Looking after your processes and applications is part of every Atlas Copco employee's mission and this goes far beyond the compressor room. Inspecting your piping system for leaks, assessing pressure drops, and checking condensate drains is all in a day's work for our service teams.

Our driving force is to continue to bring sustainable productivity through safer, cleaner, more energy-efficient and cost-effective compressed air technology. Simply log onto [www.atlascopco.us/danielusa](http://www.atlascopco.us/danielusa) or call 866-688-9611 to learn more about us, our products, and how we have earned and will continue to earn our reputation.

*Sustainable Productivity*

**Atlas Copco**

# Celebrating 100 Years of Compressed Air Technology

1910      1950      1970      1980      1990      2000      2011

## 1911

- 1910: First product was a 5 HP electric motor, Hitachi was founded



- 1911: 75kW Reciprocating - First Compressor in Japan



- 1946: First Bebicon



- 1954: Oil Free 22kW Reciprocating

- 1967: Oil Free Bebicon



- 1968: First Oil Free Rotary Screw DS Series

- 1969: First Vortex Blower



- 1976: Oil Injected Packaged Rotary Screw Series

- 1977: Smallest 5.5kW Oil Injected Rotary Screw



- 1980: First DSP Series Oil Free Rotary screw

- 1985: World's First Oil Injected Scroll Bebicon



- 1981: Vortex Blower "E" Series

- 1982: World's Smallest Single Stage Oil Free Rotary



- 1986: World's Smallest Air Cooled Oil Free Rotary

- 1992: Vortex Blower "G" Series

- 1995: Oil Free Scroll SRL Series



- 2009: New Oil Free Scroll SRL Series Multiplex



- 2002: New Generation Oil Injected HISCREW2000 Series



- 2000: World's First Variable Speed Drive Oil Free Rotary



- 1999: New Generation Oil Free Rotary Screw DSP Series



- 2001: Package Scroll Bebicon



- 2005: New Oil Free Scroll SRL Series

Leading Innovation over the last 100 years, Hitachi is proud to recognize the past and present milestones of air technology. It is with this foundation that we continue our growth for the next 100 years. Please join us in our centennial celebration as we strive to provide the most reliable, environment friendly and energy conscious products.



Hitachi Oil-Less Scroll  
SRL Series Compressors



Hitachi Oil-Free Screw  
DSP Series Compressors

HITACHI AMERICA, LTD.

Air Technology Group

5808-Q Long Creek Park Drive, Charlotte, NC 28269 Tel: 704.494.3008 x28

[www.hitachi-america.us/airtech](http://www.hitachi-america.us/airtech); [airtechinfo@hal.hitachi.com](mailto:airtechinfo@hal.hitachi.com)

Hitachi Industrial Equipment Systems Co., Ltd.

**HITACHI**  
Inspire the Next

## SUSTAINABLE MANUFACTURING FEATURES

- The System Assessment** | 15

**Food Processor Reduces Compressed Air Demand**  
By Hank Van Ormer, Air Power USA
- Maintenance Saves Energy** | 20

**Automatic Leak Detection on OEM Machines**  
By Jon Jensen, SMC Corporation of America
- Technology Provider** | 22

**Nitrogen Solutions for the Food Industry Generated on Location**  
By Krista Ramsey
- Cycling Refrigerated Air Dryers – Are Savings Significant?** | 26

By Timothy J. Fox and Ron Marshall  
for the Compressed Air Challenge®
- Sustainability Projects** | 33

**Cut Costs and Stay Competitive with Advanced Energy Management**  
By Bob Zak, Powerit Solutions



20



22



33

## COLUMNS

- From the Editor** | 6
- Sustainable Manufacturing News** | 7

Archer Daniels Midland, Kraft Foods,  
General Mills, Kellogg's, Smithfield Foods, Sara Lee
- Resources for Energy Engineers** | 40

Training Calendar, People, Companies,  
Products & Literature Picks
- Wall Street Watch** | 46
- Advertiser Index** | 48
- The Job Market** | 49
- The Marketplace** | 50

**IS IT WORTH THE RISK?**

## Using anything other than Sullair replacement parts is like forcing a square peg into a round hole.

Sullair compressed air systems consist of highly engineered components, carefully matched for capacity and pressure and are designed for total system integration to achieve maximum performance and energy efficiency.

### Maintaining the system

The dependability of a Sullair system relies on proper maintenance and quality parts. In fact, all Sullair service parts are designed for Sullair equipment and are built to exacting standards.

Sullair components must be routinely inspected and maintained to ensure that you'll always get the productivity your Sullair system was designed to deliver — at the lowest total life-cycle cost.

### Lubricant technology leadership

Sullair pioneered the lubricated rotary screw compressor and today leads in the development of long-life and biodegradable lubricants that eliminate environmental pollution, improve economics, and maximize performance.

### Sullair's name – inside and out

When replacement parts are needed, use only those from Sullair. Why? Because they are good enough to earn the Sullair name. **Remember, installing anything other than a Sullair part in your compressed air system is like forcing a square peg into a round hole. Is it worth the risk?**



[www.sullair.com](http://www.sullair.com)

Sullair Corporation is a subsidiary of Hamilton Sundstrand Corporation. Hamilton Sundstrand is a subsidiary of United Technologies Corp. (NYSE: UTX)



# FROM THE EDITOR

## Food Processing Industry



Private (non-government) industry works its' tail off. From small (ok, very small) companies like Compressed Air Best Practices® to giants like Archer Daniels Midland – companies on solid ground have their high rates of productivity to thank. Individual employees are more productive thanks to technology, training, longer hours, and better time management. One person now does what two to four people used to do. Capital invested is very selective and has high rates of return. Financial management in private industry is brutally efficient and productive.

Can we say the same of government — regardless of which football team (I mean political party) is in power? What would happen if a regiment of CEM's (Certified Energy Managers) and lean process/manufacturing professionals was unleashed in Washington D.C.? Do any efficiency/productivity metrics already exist for the different braches of federal/state/local government? I think I know the answer.

Sorry, I digress. Let's get back to our efficient world in the factories where it's "be efficient or cease to exist." The System Assessment of the Month, written by Mr. Hank Van Ormer, details demand-side air flow reductions found in a food processing plant. The plant reduced their energy costs by 29% by introducing a leak management system, replacing open blows, adding automatic controls to venturi vacuum generators, and replacing air vibrators.

Pneumatics represent the "next-frontier" in compressed air demand-side savings opportunities. Jon Jensen, from SMC Corporation of America, describes their new ALDS system capable of providing automatic leak detection on OEM machines. The pneumatics on OEM machinery (very common in the food industry) are responsible for a high percentage of all compressed air leaks and this is an interesting solution.

On-site nitrogen solutions are supplied by Generon Innovative Gas Solutions. We provide you with an article describing their on-site solutions as well as the different nitrogen specification levels found in industrial applications. An area of opportunity I often encounter, is when nitrogen is being used for the whole plant when only 25% of the plant needs it. An on-site solution for nitrogen can allow the rest of the plant to use compressed air.

The Compressed Air Challenge® provides us with an overview of cycling refrigerated air dryers. Timothy J. Fox and Ron Marshall review the energy efficiencies of thermal mass, digital scroll and other technologies and provide interesting benefit comparisons. They also put the energy costs of dryers in perspective within a compressed air system.

As facilities become more sophisticated in their energy use — systems must all work together. Compressed air is no exception as we discover opportunities in "sub-zones" of the system. Bob Zak, from Powerit Solutions, provides us with an excellent article on how an advanced energy management system (EMS) allows factories to implement demand control, demand response, dynamic price optimization, and energy efficiency projects simultaneously.

We hope you enjoy this edition. Thank you for your support and for investing in *Compressed Air Best Practices*®. 

### ROD SMITH

*Editor*

*Tel: 412-980-9901*

*rod@airbestpractices.com*



**“What would happen if a regiment of professional energy conservation managers and lean process/manufacturing professionals was unleashed in Washington D.C.? Do any efficiency metrics already exist for the different braches of government?”**

— Rod Smith



# SUSTAINABLE MANUFACTURING NEWS

## Archer Daniels Midland, Kraft Foods, General Mills, Kellogg's, Smithfield Foods, Sara Lee

SOURCED FROM THE WEB

### Archer Daniels Midland Reduces Energy Consumption

ADM views reducing energy use as a key means of reducing the emissions associated with energy generation, and, therefore, to improving our environmental profile. In 2008, ADM convened a cross-functional, cross-divisional Energy Resource Management Working Group to help standardize the way we measure and report energy metrics companywide. The group was also charged with helping the company reduce its usage on a per-unit of production

basis through facility assessments, process improvements and the development of energy plans specific to company divisions.

Based on the group's work, in 2010, ADM's Sustainability Steering Committee approved a goal of achieving a 10% companywide improvement in energy efficiency by 2015 through targeted efforts in areas such as plant scheduling, equipment selection, process changes, and colleague awareness-building

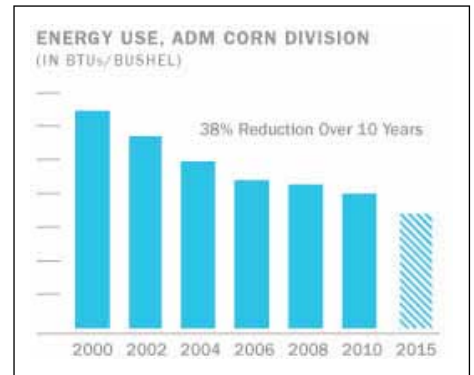

## Air So Clean You Can Taste It

Specify SPX Air Treatment Products



Compressed air is widely used as an energy source in plant operations. Clean, dry air is critical to optimize production and ensure quality of the finished product. SPX HES Series desiccant air dryers and compressed air filters deliver ISO 8573 Quality Class air meeting stringent food processing requirements.

To learn more about the benefit of SPX products and ISO 8573 Air Quality Class standards, feel free to contact us.

SPX Flow Technology  
TEL: 724 | 745 | 1555  
hankison.inquiry@spx.com  
www.hankisonintl.com  
www.spxft.com



## SUSTAINABLE MANUFACTURING NEWS

Archer Daniels Midland, Kraft Foods, General Mills, Kellogg's, Smithfield Foods, Sara Lee

and education related to energy use and conservation. This added efficiency will build on the savings already achieved by ADM's Corn business unit, which has reduced the energy needed to process a bushel of corn by 38% since the year 2000. This business unit is responsible for approximately 60% of ADM's overall energy use.

The efforts of facilities such as ADM's BioProducts unit in Decatur, Illinois, offer insight into some of the techniques the company will employ to reach its 2015 target. In 2009, the BioProducts group established a Sustainability Task Force to implement energy-efficiency measures throughout the plant's operations. By developing a PC-based energy metrics "dashboard," conducting regular energy audits, and holding colleague energy-awareness seminars, the group reduced energy consumption by 4.4 million kilowatt hours during the 2010 fiscal year and is developing strategies to advance these conservation efforts in 2011 and beyond.



Source: [www.adm.com](http://www.adm.com)

### General Mills Minimizes Their Impact

In fiscal year 2010, General Mills announced a 6% reduction in its energy consumption rate over five years (from the 2005 baseline). While progress fell short of the 15% goal, several of the company's businesses successfully achieved double-digit energy reductions by the end of fiscal year 2010.

General Mills also has achieved a reduction in energy consumption, in part, by investing in renewable energy at facilities and by identifying new and innovative ways to save energy. General Mills' plant in San Adrian, Spain, now gets 100% of its electricity from a utility company that uses only renewable energy sources such as wind and solar power.

General Mills has committed to a 20% reduction in its energy usage rate by the year 2015 from a 2005 baseline. In order to reach this goal, General Mills will continue to use renewable resources where feasible and embed smart energy-saving technology into the company's manufacturing culture.

As General Mills strives to cut energy usage across its facilities, the company also faces the challenge of meeting consumer demand for products, such as cereal and granola

bars, that require more cooking or toasting during production and in turn, require more energy. Despite this challenge, the company is committed to meeting the 20% goal — and believes it is attainable — as energy savings systems and procedures have become widely embraced by employees.

General Mills' distribution center in Methuen, Mass., became the first General Mills facility in the United States to produce its own electricity from solar panels. The panels atop the warehouse produce enough electricity to supply 55% of the facility's annual electricity needs — 80% of its consumption in the summer and 40% during the rest of the year.

Oat hulls, which are left over from the making of Cheerios and other products, are a renewable energy source. Oat hulls generate about as much BTU (a unit of energy) as bituminous coal, and they burn just as efficiently. General Mills' Fridley, Minn., flour mill began burning oat hulls in December 2010. The oat hulls now provide nearly 90% of the steam needed to heat the plant and produce oat flour, serving as a cleaner and more sustainable form of energy for the facility. Burning the oat hulls saves

### Kraft Foods Sustainability; 6 Areas of Focus

Sustainability is a strategic business priority for Kraft Foods. We focus on areas that matter most to our business and where we can make the biggest impact. Our "sustainability Wheel" represents our focus areas and serves as our framework for building sustainability into everything we do. We use the wheel to measure and reward improvement. Our six areas of focus are: agricultural commodities, packaging, energy, water, waste and transportation/distribution.

in 2006, we set aggressive five-year goals. In 2010, after integrating the Cadbury and Lu businesses and looking to continuously

improve upon our successes, we expanded our initial goals. For our 2011–2015 goals, we've added sustainable agriculture and transportation to what we're measuring.

By the end of 2015, using 2010 as our base year, we plan to:

- Increase sustainable sourcing of agricultural commodities by 25%
- Eliminate 50,000 metric tons (100 million pounds) of packaging material
- Reduce energy use in our manufacturing plants by 15%

- Reduce energy-related carbon dioxide emissions in our manufacturing plants by 15%
- Reduce water consumption in our manufacturing plants by 15%
- Reduce waste at our manufacturing plants by 15%
- Reduce 80.5 million kilometers (50 million miles) from our transportation network

From 2005 to 2010, we reduced our energy use by 16% and our energy-related carbon dioxide emissions by 18%. By 2015, we're



nearly \$400,000 per year and cuts the plant's carbon footprint by approximately 20%. Oat hulls not used by the facility are burned by a Minnesota-based biomass plant, generating enough electricity to power approximately 17,000 homes.

In order to identify energy saving opportunities at the General Mills Covington, Ga., plant, the energy team installed 23 energy meters on several pieces of major equipment. The meters enabled the Covington team to better understand the impact of system changes using real-time energy consumption data. In one case, fixing leaking steam coils, a bad air flow sensor and a steam regulator cut the hourly cost of operating a device by well over half. The metering project led to an annual savings of more than \$600,000. The facility is now more sustainable and energy efficient.

Source: [www.csr.generalmills.com](http://www.csr.generalmills.com)



aiming to reduce our energy use and energy-related carbon dioxide emissions by an additional 15% each. We're making progress by changing our operations, improving facilities and training employees to modify their behavior. We're also investing in new technologies for lighting, heating, refrigeration, processing and packaging.

Source: [www.kraftfoods.com](http://www.kraftfoods.com)



## Give your production a great new look

Since 1901, Chicago Pneumatic has been building products that help build America

### The Chicago Pneumatic difference:

- High quality compressed air to protect your product quality
- Legendary reliability to safeguard your production
- Maximum energy efficiency to reduce your power usage
- Low noise to allow installation in the heart of your workplace



Check out our full line of air compressors, dryers and filters at [www.cp.com](http://www.cp.com) or call us at **877-861-CPAC (2722)**

[www.cp.com](http://www.cp.com)

High-performance products.  
Designed for you!

# SUSTAINABLE MANUFACTURING NEWS

Archer Daniels Midland, Kraft Foods, General Mills, Kellogg's, Smithfield Foods, Sara Lee

## Kellogg's Energy And Ghg Emission Performance

In 2010, our global energy use and GHG emissions per metric tonne of food produced both continued to decrease — energy use by 1.6% and GHG emissions by .7% over 2009. Since 2005, our baseline year, our energy use and GHG emissions per metric tonne of food produced are down 7.5% and 9.8%, respectively. Given our continued progress, we expect to meet our 15 to 20% reduction goals for GHG and energy by 2015.

Kellogg Company's energy and GHG reductions since 2005 are the result of many energy-saving projects and initiatives, small and large, at our facilities worldwide. Our plant in Botany, Australia, for example, has reduced its energy usage by 7% since 2009,

even as production at the plant increased 2%. The plant accomplished this by installing an energy management system aimed at improving the control and monitoring of key equipment, such as air compressors, boilers, chilled water units and cooling towers.

In another example, our cereal plant in Belleville, Ontario, reduced electricity use by 9% and gas use by 11% in 2010 by improving its manufacturing processes. For example, they installed new machines that create less excess “over spray” when spraying coating onto product. This new technology reduced by more than 100,000 pounds the amount

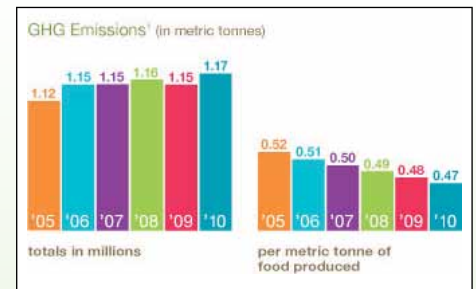
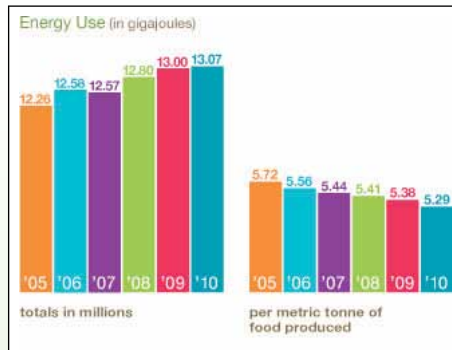

# ENERGY KAIZEN EVENTS

- Food Packaging Plant Saves \$70,000 or 1.1 Million kWh per year.
- Paper Mill Saves \$207,000 or 4.5 Million kWh per year.



Get your **FREE** Subscription to Compressed Air Best Practices® Magazine to **learn how to save energy.**

Subscribe at  
[www.airbestpractices.com](http://www.airbestpractices.com)

of coating required to make 50 million pounds of product. This in turn saved electricity, since less of the coating needs to be made. The Belleville plant also implemented a more effective inspection method for oven doors. The new method better detects poor door seals so they can be repaired, thereby reducing heat wasted and gas used.

Source: <http://kelloggcompany.com>



### Smithfield Foods Environmental Management System

At our John Morrell, Smithfield Packing Company, Farmland Foods, and Murphy-Brown subsidiaries, we use an organized Environmental Management System to identify and manage every part of our operations that could have an effect on the environment. The focus is not only on compliance with applicable rules and regulations, but also on finding ways to continuously improve. EMS successes to date include:

- Reduced water use by 15%, natural gas use by 10%, electrical use by 17% and reduced solid waste generation by 21% from fiscal year 2007 through fiscal year 2009 at our John Morrell subsidiary's Armour-Eckrich group of facilities
- Reduced electrical use by 7,493,467 kWh/year the John Morrell — Sioux Falls, SD facility by implementing a new refrigeration control system
- Offset 492,851 mMBTU of natural gas use per year by adapting a boiler at the John Morrell — Cudahy, WI facility to burn animal fat and grease extracted from the plant's wastewater treatment system

# EDMAC

Shopping for air compressor parts,  
*made simple*



- **The EDMAC Guaranteed Price Promise**
- **An industry leading database for searching and cross-referencing air compressor parts**
- **A world class team of experts with technical knowledge and professional experience**



11313 Steele Creek Road, Charlotte, NC 28273

Phone: 704-504-4066 • Fax: 704-504-4082

Toll Free: 1-877-43EDMAC

E-mail: [sales@edmac.com](mailto:sales@edmac.com)

## SUSTAINABLE MANUFACTURING NEWS

Archer Daniels Midland, Kraft Foods, General Mills, Kellogg's, Smithfield Foods, Sara Lee

- Reduced energy consumption by 8 mMBTU/hr and saved 4 million gallons of water per year by installing a steam condensate return system at the Farmland — Denison, IA plant
- Saved 1.5 million gallons of water/year by installing a system to reuse packaging machine cooling water at the Farmland — Cumming, GA plant
- Reduced water consumption by 12 million gallons/year by installing high

efficiency spray nozzles throughout the Smithfield Packing Company — Portsmouth, VA plant

- Saved 50,400 gallons each production day by implementing water conservation upgrades to the casing operation at the Smithfield Packing Company — Tar Heel, NC plant

For Smithfield Foods' US operations, projects implemented at individual plants in fiscal year

2009 resulted in 516,536,287 gallons/year in reduced water use, 124,621 decatherms/year in natural gas reductions, 2,220,485 kWh less consumed/year, as well as 889 tons of annual CO<sub>2</sub> emission reductions.

Source: [www.smithfieldfoods.com](http://www.smithfieldfoods.com)



### Sara Lee Sustainability

Sara Lee Corporation is a global manufacturer and marketer of high-quality, brand-named food and beverage products. This policy pertains to all activities of Sara Lee Corporation that consume energy and emit greenhouse gases.

Energy use and greenhouse gas emissions occur during each step of the life cycle of our products from raw material to end-use. Because energy usage and greenhouse gas emissions can affect climate change, we are committed to minimize energy usage and greenhouse gas emissions during the manufacture of our products and to work with partners, suppliers, customers, consumers and stakeholders to help minimize their energy usage and greenhouse gas emissions related to our products.

We will:

- Measure the energy usage and greenhouse gas emissions from our direct operations (GHG Protocol scope 1 and 2)
- Set energy use and greenhouse gas emissions goals for our direct operations and, where possible and relevant, associated indirect aspects (GHG Protocol scope 3)
- Reduce energy use and emission of greenhouse gases and their precursors by a combination of improved energy efficiency, technology change and the use of biofuels, biomass and other renewable energy
- Consider energy usage and greenhouse gases in our decision-

making processes for deployment of capital and new product planning

- Engage our employees in a company-wide culture of responsible energy management
- Work to help minimize energy and greenhouse gas emissions throughout the lifecycle of our products by engaging with partners, suppliers, customers, consumers and stakeholders
- Consider adoption of carbon offset programs only when we are explicitly required to do so, and only when reliable certification standards and/or strict quality assurance schemes are available
- Understand the impact of energy and greenhouse gas trends and the risks they may pose on our business and the wider community

### Energy Use & Greenhouse Gas Emission Performance

The average energy consumption for our manufacturing operations between 2005 and 2009 was 3.48 gigajoules used per metric ton of production, across all product lines. Since setting goals in 2009 to reduce our energy consumption, we achieved our lowest level of energy use, 3.37 gigajoules per metric ton of product produced, in 2010.

The source of energy consumed by our manufacturing facilities is approximately one-third purchased electricity and two-

thirds fossil fuels. Renewable energy sources contributed 3% of our total energy consumption in 2010, versus 1% in 2005.

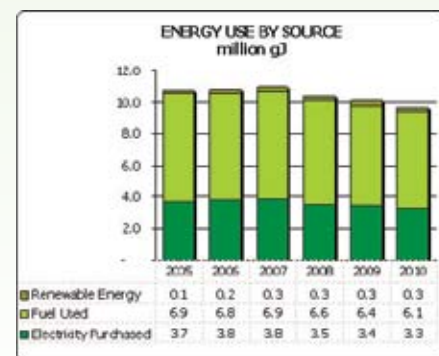

The chart of our greenhouse gas emissions covers 100% of Sara Lee owned production facilities for 2005 through 2010. Since 2007, we have increased the number of facilities captured in our annual report of carbon dioxide emissions submitted to the Carbon Disclosure Project (CDP), including offices and distribution facilities. Our CO<sub>2</sub> intensity since 2005 has been relatively unchanged, hovering around 0.30 to 0.32 metric tons of CO<sub>2</sub> emitted per metric ton of product produced.

Source: [www.saralee.com](http://www.saralee.com)



## Protecting the planet and protecting your profits one air drop at a time

The new CDI 25 is designed and priced to monitor air usage at every piece of equipment in your plant. It reveals waste without requiring central monitoring. A minimum-flow alarm indicates leakage by blinking if flow does not drop below a specified level. An average-flow alarm indicates excessive usage; a totalizer allocates usage.

Like our other meters, the CDI 25 measures mass flow by thermal dispersion. It requires two small holes in a pipe and 24-Volt dc power. An optional wall-plug supply is available.

The CDI 25 is available factory-direct in packages of ten and fifty. A limited number of samples are available. Please call or email for samples and for the names of stocking distributors.



[cdimeters.com](http://cdimeters.com)

866-885-2462 • [sales@cdimeters.com](mailto:sales@cdimeters.com)

# SUSTAINABLE MANUFACTURING NEWS

Archer Daniels Midland, Kraft Foods, General Mills, Kellogg's, Smithfield Foods, Sara Lee

## Heinz Sustainability Goals and Results

From sustainable agriculture and energy-efficient manufacturing processes to eco-friendly packaging initiatives, Heinz is proving that smart business is compatible with environmental stewardship. In factory after factory, a transformation is underway to improve sustainability measures and reduce operating costs by installing more efficient equipment, modernizing business processes and implementing new technologies.

Heinz is focused on these key environmental areas:

- Lowering GHG emissions, including those related to agriculture and the transportation of goods, while increasing awareness programs for employees to implement at home and at work
- Reducing waste through packaging innovation and recycling
- Conserving water
- Improving energy efficiency

Operations risk managers at each Heinz factory are responsible for the safety and environmental impacts of the plant. They monitor compliance with environmental and safety regulations and develop and coordinate programs for energy management, GHG reductions, recycling, packaging waste and waste disposal.

Our commitment to protecting the global environment accelerated with our formal

announcement of Company-wide sustainability goals in May 2008.

These global goals, which we hope to achieve by Fiscal 2015, include a 20% reduction in the generation of GHG emissions per unit of finished production, compared to the baseline year of Fiscal 2005. Heinz is pleased to report significant progress in reaching this goal, with an approximate 13.4% reduction in GHG emissions per unit of production through the implementation of various programs as of the end of Fiscal 2009.

- **Energy consumption:** 20% reduction (per unit of finished production) through improved operational efficiency
- **Renewable energy:** 15% increase in usage of renewable energy sources, including solar, biomass and biogas
- **Water:** 20% reduction (per unit of finished production) through reuse and improved sanitation techniques
- **Solid Waste:** 20% reduction (per unit of finished production) through increased recycling and reuse of waste
- **Packaging:** 15% absolute reduction by the introduction of alternative packaging materials and reduction of existing packaging use for various brands and containers

- **Agriculture:** 15% reduction of carbon footprint, 15% reduction of water usage and improvement of tomato crop yields by 5% through use of hybrid tomato seeds that require fewer inputs such as water, fertilizer, pesticides and fuel to harvest
- **Transportation:** 10% reduction of fuel consumption (e.g., diesel fuel) through improved efficiency of product distribution network
- **Employees:** Implementation of programs encouraging employee engagement through an awareness and voluntary personal sustainability campaign

Heinz is targeting areas of our operations that most impact the environment, as well as our manufacturing costs. Heinz facilities around the world have been proactively implementing new technologies, equipment and processes to operate more efficiently. We are investing millions of dollars in our plants and expect to recoup those investments through operational savings. Importantly, these improvements and investments are reducing the Company's environmental impact and enhancing the ecological health of the planet.

We are proud of our accomplishments thus far as Heinz seeks additional ways to enhance our environmental performance. Outcomes for our areas of focus with standardized metrics are showcased in the chart below.

Source: [www.heinz.com](http://www.heinz.com)

	2005*	2008	2009
GHGs (metric tons CO <sub>2</sub> -eq"/per metric ton production)	0.203	0.193	0.175
Energy (kWh/metric ton production)	822	763	693
Water (cu-m/per metric ton production)	7.71	7.39	6.50
Waste (metric tons/per 100 metric ton production)	2.16	1.88	1.57





# THE SYSTEM ASSESSMENT

## Food Processor Reduces Compressed Air Demand

BY HANK VAN ORMER, AIR POWER USA

### Introduction

This Midwestern prepared food company now spends \$131,011 annually on energy to operate their compressed air system. This figure will increase as electric rates are raised from their current average of 6.0 cents per kWh. The set of projects recommended below will reduce these energy costs by \$38,736 or 29%.

This plant produces frozen foods. The plant runs production five days a week with limited production on weekends. Several years ago, an unused part of the plant was expanded to produce and package a new product line. This area is fed through a single 2 ½" header running from the compressor room and over top of the production area. Many feeds and then following sub feeds come off of this straight run of header. This new production area has a significant low pressure problem at the end of the plant during particularly heavy manufacturing runs. Due to space constraints in this article, we will focus on the demand-side system opportunities that were found to realize energy savings.

### Demand-Side Projects

Please note that all the demand-side system savings, listed in this article, depend on the capacity control system effectively translating lower air use into reduced electric cost. The current system has this type of unloading controls. With today's piping system, the controls will accomplish this goal.

The demand-side projects, described in this article, include a leak management program, replacing open blows, adding automatic controls

to venturi vacuum generators, and replacing air vibrators.

### Compressed Air Leak Survey

A survey of compressed air leaks was conducted at the plant and 13 leaks were identified, quantified, located, and listed. Potential savings totaled 73 cfm for the 13 leaks that were identified. Leaks were not tagged because we had paper tags. Plant maintenance personnel were in attendance when they were located.

The plant has a continuing leak identification and repair program. The plant runs leak-checks routinely with an ultrasonic locator. This is usually implemented during 2nd and

3rd shifts. It is very important that this program continue with great intensity.

Ultrasonic leak locators were used to identify and quantify the compressed air leaks. Estimation of leak size was achieved by noting the intensity of the signal by the operator, type of leak, and observation. The estimates are made on a conservative basis and probably understate the magnitude of the volume of leaks.

COMPRESSED AIR *ALSO* PRODUCES OILY CONDENSATE\*

Help ensure it doesn't impact our  
**ENVIRONMENT.**

JORC Zero Air Loss Drains and  
Condensate Cleaners provide  
sustainable condensate management.



\*A 250 hp compressor can produce 40,515 gallons of oily condensate per year.

**JORC**  
Global Focus on Condensate Management

JORC Industrial LLC • 1146 River Road • New Castle, DE 19720  
Phone: 302-395-0310 • Fax: 302-395-0312 • info@jorc.com • www.jorc.com

# THE SYSTEM ASSESSMENT

## Food Processor Reduces Compressed Air Demand

	SAVINGS	AVG KW	KWH	SAVINGS	COST
<b>DEMAND-SIDE SYSTEM</b>					
5. Implement ongoing leak management program	83 cfm	9.12 kW	79,891 kWh	\$8,991	\$4,791
<b>POTENTIALLY INAPPROPRIATE AIR USES</b>					
6. Replace open blows – 38 open blows to be modified; average cfm reduction	194 acfm 60% recovered	21.15 kW	185,274 kWh	\$11,106	\$2,000
7. Add automatic controls to Venturi vacuum generator(s) on line 7 case erectors	30 cfm	3.3 kW	28,908 kWh	\$1,718	\$250
8. Replace air vibrators with electric units – 2 vibrators – one (1) on line 3 and one (1) in Powdered Sugar	14 cfm	1.4 kW	12,264 kWh	\$732	\$650

Shutting off the air supply to these leaks when the area is idle would save significant energy use. Reducing the overall system pressure would also reduce the impact of the leaks, when air to the air cannot be shut off. Repairing the leaks can save additional energy. The savings estimates associated with a leak management program are based on the unloading controls of the compressors being able to effectively translate less air flow into lower cost.

### ✓ RECOMMENDED PROJECT #1 — Implement ongoing leak identification and repair program with ultrasonic locators.

Estimated reduction of air flow with proposed project	83 cfm
Recoverable savings from air flow reduction [Section 2.3]	57.42/ cfm year
Annual electric cost savings with proposed project	\$4,791/ year
Unit cost of leak repairs (\$15 materials per leak and \$35 labor per leak x 13 leaks)	\$650
<b>Total project cost (materials and installation)</b>	<b>\$650</b>

### Replace Blowoff Air with Amplifier Nozzles

Regardless of application, there are several guidelines that should always be applied to compressed air being used for open blow off:

- Use high pressure only as a last resort
- All blow off air should be regulated
- All blow off air should be regulated to the lowest effective pressure — higher pressure means higher flow, which may not be needed
- Use Venturi air amplifier nozzles whenever and wherever possible— this will usually reduce blow off air at least 50%, freeing up more air flow for other applications
- All blow-off air should be shut off (automatically) when not needed for production

Plants with many 1/8 and 1/4 inch lines running as blow off on units will use approximately 10 and 25 cfm each, respectively, at 60 psig.

One savings approach is to use an **air amplifier**, which requires less compressed air. Air amplifiers use “Venturi” action to pull in significant amounts of ambient air and mixing it directly into the air stream, which amplifies the amount of air available at the point of use. Air amplifiers have amplification ratios up to 25:1. Using 10 cfm of compressed air can supply up to 250 cfm of blow off air to the process and generate a savings of a 15 cfm compressed air per 1/4-inch blow off. Savings may be available using 1/8-inch lines, but the cost effectiveness will not be as great.

Another method for blow off to be investigated is the use of “blower generated” low pressure

air. This air is much less costly to produce on a \$/scfm basis. It is the volume of air (scfm) that creates the mass or weight of the air that performs the blow off. The pressure influences the “thrust” out to the end of the nozzles where it quickly dissipates. Often a “higher volume” or weight of air at lower thrust (pressure) improves productivity and quality of the blow off over the higher pressure version.

### ✓ RECOMMENDED PROJECT #2 — Replace 38 open blows with air amplifiers nozzles.

Total air flow reduction	194 cfm
Recoverable savings from air flow reduction	\$57.25/ cfm year
Total annual electric savings	\$11,106/ year
<b>Total nozzle cost (materials and installation – 38 new nozzles)</b>	<b>\$1,330</b>

### Add Automatic Controls to Vacuum Generators

In order to create a vacuum, some kind of air pump or vacuum pump is required to evacuate the volume. There are two basic approaches to accomplish this task: mechanical pumps and vacuum generators (or ejector pumps).

Vacuum generators are often selected for more localized or “point of use” vacuum applications, due to the smaller volumes they handle and their faster local response times. Manufacturers of production machinery often supply them as standard equipment. There are two basic types of ejector pumps: single-stage vacuum generators and multi-stage vacuum generators.

Single-stage vacuum generators use compressed air by accelerating the air through the restrictor tube to create a Venturi effect to evacuate the required volume of air. These single-stage Venturi generators are somewhat limited in their ability to fit many applications efficiently,

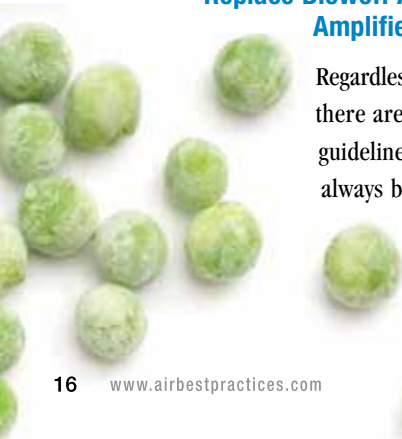





TABLE 1: LEAK SURVEY RESULTS

NO.	LOCATION/DISTRIBUTION	EST. SIZE
1	Air compressor receiver air quick disconnect	5
2	Line 4 Oil sprayer control – leaking regulator	5
3	Line 5 under conveyor belt ahead of labeler	5
4	Line 5 Case packer hole in plastic hose to cylinder (rubs on guard – correct instruction)	5
5	Sauce cook – Kettle control cabinet	6
6	Pesto kitchen control cabinet air-operated solenoid “blown” inside cabinet	6
7	CIP No. 1 – control cabinet – air-operated solenoid “blown” inside cabinet	6
8	Line 7 fitting connector to small Ballston filler	5
9	Line 7 palletizer leak under stand	7
10	Line 7 Dacmec lifter leak “inside” control box	5
	New Production Area – Has high ultrasonic background noise due to the many “blow offs” operating. These need to be shut off when looking for leaks – the high ultrasound background can “mask” many leaks.	
11	Line 11 Case packer Robox – cylinder rod seal on conveyor	12
12	Line 10 Scale hopper filter drain (may be solenoid)	5.7
13	Powdered sugar – auto jet filter diaphragm on solenoid and three (3) smaller regulators	10
	<b>TOTAL</b>	<b>83.7 ACFM</b>

since their basic design is set to accommodate either the highest flow or highest volume requirement. Typically, this type of vacuum generator has a ratio of compressed air consumption (scfm) to vacuum flow (the rate at which atmospheric pressure is removed from a system) of no better than 1:1 and sometimes as high as 2:1 or 3:1.

Multi-stage vacuum generators were developed to improve this efficiency for many applications. The multi-stage units use a series of ejectors and nozzles that allow compressed air to expand in controlled stages. This usually improves the ratio of compressed air consumption to vacuum flow to a level of up to 1:2 or more. Multi-stage units are also quieter.

# Dew Point Measurement in Compressed Air

Measure dry air with accuracy, reliability, and speed even after exposure to water or wet air.

- Fast response time
- Low maintenance (calibrate every 2 years)
- High resistance to contamination

**FREE**  
Application Note

Get the **FREE** Application Note “Increasing Compressed Air Plant Efficiency” download at [www.vaisala.com/dds](http://www.vaisala.com/dds)



[www.vaisala.com/dds](http://www.vaisala.com/dds)

**VAISALA**

# THE SYSTEM ASSESSMENT

## Food Processor Reduces Compressed Air Demand

TABLE 3: LIST OF BLOWOFF LOCATIONS

LOCATION	SIZE	CFM USAGE	UTILIZATION	AVG CFM USAGE AS APPLIED	CHANGE IN UTILIZATION	EST SAVINGS CFM NOZZLE	EST SAVINGS CFM TIMED	NOZZLE	EST USAGE CFM	EST AVG AIR	
1	Line 4	1/4"	10	100%	10	Inst demand control	3.5	3	Fixed	3.5	6.5
Tortellini/Dryer – There are no air blows on conveyor Line 3 & 5 sensor											
2	Sauce	1/4"	10	80%	8	—	5	—	Fixed	5	5
Conveyor – Blows caps down 1/4 tube / also 4 1/8 tubes – does have auto shut off											
3	Line 7	1/4"	10	100%	10	Inst demand control	3.5	3	Adj	3.5	6.5
Labeler / Blow off bottom of package for imprint											
4	Chub KP	25 cfm	24	100%	24	Inst demand control	—	12	—	12	12
Cold air gun to cool glue seal – air on when machine off											
5	Line 10	80	80	100%	80	Inst demand control	40	8	Wedge	32	48
8 air dispersion nozzles run all the time – replace with amplifiers and demand control – 2 black / 6 yellow											
6	Line 12	100	100	100%	100	Inst demand control	50	10	Wedge	40	60
14 air dispersion nozzles – Raque machine – run all the time – replace with amplifier and demand control											
7	Line 11	90	90	90%	90	Inst demand control	45	9	Wedge	34	56
12 air dispersion nozzles – Raque machine – run all the time – replace with demand control & amplifier nozzle											
8	5, 6, & 7	This air is used to heat the belt and avoid freezing. It is quite conceivable with 25-to-1 amplifier that the added volume mass will heat a greater area and fewer nozzles can be used at lower flow each for even greater reduction									
<b>TOTAL ACFM SAVED</b>										<b>194 CFM</b>	

Energy cost escalates as the vacuum flow goes down with Venturi generators, so it is very important to only run a Venturi vacuum generator at the minimum vacuum flow, minimum acceptable “on time” cycle, and at the lowest effective pressure. Properly applied, Venturi generators can be very power efficient and can enhance productivity.

If there is a large central vacuum system already in place and running with excess capacity, tying the vacuum generators requirement to it will probably generate energy savings.

### Current Application

There are compressed air vacuum generators throughout the plant. The majority are used in packaging, palletizing, case erection, etc. Most of the vacuum generators were set to shut off automatically when production was off. One exception was on Line 7 case erectors with three (3) PIAB M150’s were running all the time, even though the machine was not operating.

These use about 10 cfm each and, if auto controlled, would only run 50% of the time.

### ✓ RECOMMENDED PROJECT #3 — Add automatic controls to Venturi vacuum generator on M150’s at Line 7 case erectors.

Estimated flow of Venturi vacuum without auto shut off	60 cfm
Total air flow in current system	60 cfm
Air flow reduction with auto shut-off	50%
Air flow savings with auto shut-off	30 cfm
Recoverable energy savings	\$57.25 / cfm year
Annual estimated energy savings	\$1,718 / year
Equipment and installation cost to add automatic controls	\$250

In general, vacuum generators:

- Use compressed air whenever they are on
- Use less air and are more efficient when in a multi-stage configuration than they are as single-stage units under certain loads
- Need to be carefully chosen — selecting the right pump for each specific application is not always easy
- Are probably not the right approach when a large and/or continuous volume is called for
- Will waste a significant amount of compressed air when pulling a lower vacuum
- Will waste a significant amount of compressed air when pulling a vacuum at any time it is not required for production
- May be less economical than a “central mechanical” pump when there are a significant number of vacuum generators used in a single area

Vacuum generators are very convenient and very responsive, but less efficient compared to positive displacement pumps (e.g., larger rotary screw, vane, or reciprocating pumps), which are the better choice when conditions require large flow, but offer potentially slower response time.

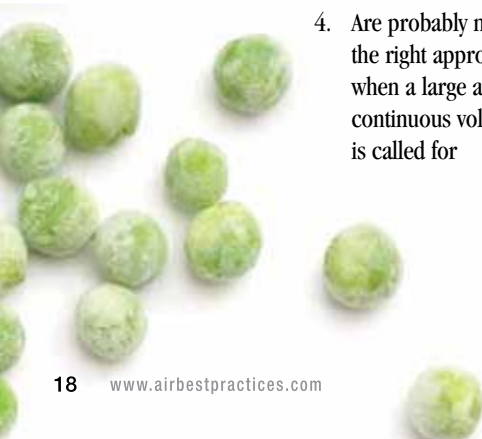

**Air Vibrators**

Air vibrators are used to keep product or packaging moving or separated — e.g., keeping lids separated prior to sealing. If a plant employs air vibrators that use about 10 cfm each, they will require about 2.5 hp or more to produce the same as a similar electric vibrator, which might use about 0.25-hp input energy.

A list of potential air vibrator retrofits is provided below.



# A New Twist in Energy-Efficient Air

Learn how to save energy and increase operating efficiencies with the Aerzen Delta Hybrid Rotary Lobe Compressor.



LIST OF AIR VIBRATOR RETROFITS					
	LOCATION	QTY	CURRENT AIR FLOW (CFM)	USAGE (%)	NET SAVINGS (AVG CFM)
#1	Line 3	1	10	20%	8
#2	Powdered Sugar	1	12	50%	6
<b>TOTAL</b>					<b>14</b>

✓ **RECOMMENDED PROJECT #4** — Replace current air vibrators with electric units.

Total net air savings	14 cfm
Recoverable savings from air flow reduction	\$57.25/cfmyear
Annual electric use in current applications	\$801 /year
Unit electric demand per electric vibrator @ .25 hp	.25 kW
Estimated annual hours of operation for new equipment	4,640 hours/year
Annual electric cost in proposed applications	\$69.30 /year
Net annual electric savings from project	\$732 /year
<b>Total cost to purchase and install electric vibrators (2 units)</b>	<b>\$650</b>

**Summary**

Most plants can benefit from an ongoing demand-side reduction and leak management program. Generally speaking, the most effective programs are those that involve the production supervisors and operators working in concert with the maintenance personnel. **BP**

For more information please contact Hank Van Ormer, Air Power USA, tel: 740-862-4112, email: hank@airpowerusainc.com, www.airpowerusainc.com

- Substantial energy savings
- Reliable and durable
- Space saving, easy handling
- Reduction of maintenance costs
- Simple operation up to +22psig / -21”Hg

## Delta Hybrid



**AERZEN**  
One step ahead.

To learn more, visit [www.aerzenusa.com](http://www.aerzenusa.com)

108 Independence Way • Coatesville, PA 19320  
(610) 380-0244 • [inquiries@aerzenusa.com](mailto:inquiries@aerzenusa.com)



# MAINTENANCE SAVES ENERGY

## Automatic Leak Detection on OEM Machines

BY JON JENSEN, ENERGY CONSERVATION MANAGER, SMC CORPORATION OF AMERICA

### Why So Many Air Leaks — Even Today?!

Energy conservation has been much talked about lately, in the media, the government, and at the water cooler. Lean manufacturing is also a popular topic these days, as are any ways to increase productivity, reduce costs, and increase profitability.

One topic that has historically been overlooked is the cost of compressed air in a facility. Studies conducted over the years by SMC Corporation of America have suggested that, of the energy consumed by a typical factory, 20% goes to the production of compressed air. Of that 20%, it's often

the case that at least 30% of that energy is wasted by leaks.



The new ALDS Automatic Leak Detection System from SMC.

Detecting and correcting leakage would seem to be of significant benefit, both in reduced operational costs, and in increasing environmental responsibility. So why does a typical factory still allow 30% of the energy used to be consumed by compressed air leaks?

### Leak Detection is Time Consuming for Maintenance

The answer is that leak detection is a costly and time consuming maintenance activity, both in labor costs and in equipment required. The typical method has been to employ an ultrasonic leak detector, essentially pointing it at every component, and listening for leaks. In a busy factory, this is difficult, and only effective if done on a regular basis. This method also calls for checking numerous components that are actually NOT leaking.

Other methods of detecting leaks include the installation of flow switches on each and every circuit, the addition of pigments or gases which would make the leak visible to the naked eye, or detectable through the use of “sniffers”, and the time-tested spray bottle of soapy water! The problem with any of these methods is that they take time, may be costly, and can only be done sporadically due to a shortage of resources. Furthermore, there are many machines (or parts of machines) that cannot be accessed during production, and, as such, cannot be accessed during a normal leakage investigation. For these reasons, large potential energy savings are disregarded.

### Automatic Leak Detection on OEM Machines

What if there were a way for a machine's control system to not only warn you if a leak developed, but also to provide a report that would indicate the total amount of leakage, the number of leaks, and the part of the system actually leaking?

SMC's Automatic Leakage Detection System (ALDS) is able to quantify the amount of leakage on a machine on a daily basis, even while the machine is in operation. The system will report the exact value of the leak in liters per minute, and provide maintenance personnel with a detailed report listing the location of each leak. For example, the system can provide a report something like:

***“Machine XX on line XY; Press cylinder XYZ leaks  
12 litres per minute in the pressing position,  
and 3 litres per minute in the home position.”***

This type of report eliminates the need to check components that are not leaking. Imagine the benefits if maintenance personnel can easily

determine that there's a leak to fix, and be directed to the component that requires attention. Not only will there be an increase in productivity, but leaks will be addressed before they have a chance to eat up the profits!

### How it Works

How does this work? The Automatic Leakage Detection System is installed on the OEM machine's main air line, and integrated with the machine's control software (PLC), thus eliminating the need for costly System Control and Data Acquisition software (SCADA). When the machine is newly installed, the ALDS system will run the machine through a complete sequence, measuring the air consumption of each actuator, and confirming that there are no leaks.

During an idle moment in the machine's daily operation, the ALDS system will perform a "Leakage Detection Cycle", operating each component in sequence again, recording the air consumption, and manipulating the data to identify each leak. In this way, leakage can be detected and a report generated that will list the amount of each leak and its location. Maintenance personnel can then concentrate their

activities only on the components that require repair, without having to check the entire machine.

Sound good to you? It certainly does to maintenance staff. Besides the reduction in energy costs, there will be a marked improvement in productivity from implementing Automatic Leak Detection Technology.

### Conclusion

Picture this scenario: In a bottling machine where multiple bottles are filled simultaneously (think 100 bottles of beer), one of the valves is leaking, causing 1 bottle out of 100 to only be partially filled. This bottle would later be rejected. If this bottling machine cycled 6 times per minute, there would be an entire six-pack wasted every minute. This is a significant cost to the bottling company, and an unnecessary waste of good beer! Imagine the increase in productivity if maintenance personnel can repair issues before they escalate to the point of causing waste. **BP**

*For more information please contact Jon Jensen, SMC Corporation of America, tel: 630-449-0562, email: [jjensen@smcusa.com](mailto:jjensen@smcusa.com), [www.smcusa.com](http://www.smcusa.com)*

**Oil Problems?**

The industry's only true and viable hydrocarbon removal and monitoring systems. Each featuring unique technologies that have received multiple certifications from the world's most recognized standards organizations.

**BEKOKAT<sup>®</sup>** is capable of removing hydrocarbons from any oil laden source down to a constant level of 0.003 mg/m<sup>3</sup>.

**METPOINT<sup>®</sup> OCV** is a real time, in-line monitoring system that can track hydrocarbon content as low as 0.001 mg/m<sup>3</sup> continuously.

Please contact us for complete product details at:  
**+1 (800) 235-6797**

**Oil and Bacteria Free Compressed Air Exclusively from BEKO.**

**What Oil Problems?**

**BEKO**  
[www.bekousa.com](http://www.bekousa.com)



# THE TECHNOLOGY PROVIDER

## Nitrogen Solutions for the Food Industry Generated on Location

BY KRISTA RAMSEY



*The New Compact PSA  
System Nitrogen Generator*

Nitrogen, an inert gas comprising 79% of the atmosphere, can be distilled from ordinary air. However, companies that use this product in their everyday operations know that it's not quite that simple and much more expensive than the stuff we breathe. The primary means of obtaining nitrogen for industrial use is to transport it onsite in liquid form, which must be shipped stored at cryogenic temperatures. But, really, what's the point of turning nitrogen into liquid for shipping, transporting it to where it's used, and then turning it back into gas?

“This process requires energy to store the liquid at cryogenic temperatures (below 300 degrees), ship it, and warm it to a gaseous state,” said Tom Jeffers, President of Houston, Texas-based Generon Innovative Gas Systems (IGS) US. “Operating costs are crucial when evaluating system payback, and energy costs comprise the main portion of these. There are two technologies to separate nitrogen out of the air we breathe, pressure swing adsorption (PSA) and hollow membrane fibers.

Generon IGS specializes in both technologies. PSA systems are more efficient for purities above 99% and hollow membrane fibers are most efficient at purities from 95% to 99%. Generon IGS is offering a solution to save time, space, and money— generate the nitrogen onsite for easy and efficient use.”



### The New Compact PSA System Nitrogen Generator

Generon IGS specializes in gas separation and compression solutions and offers various versions of nitrogen pressure swing adsorption (PSA) generators. The Compact PSA System bridges the gap between twin-tower PSAs used for high flow volumes (up to 120,000 scfh at 95% purity) and modular, bank-type PSAs with expandable flows from 85 scfh to 13,000 scfh. The new Compact PSA Nitrogen Generator allows for multiple-bed PSAs to be installed on a common skid for purities from 95% to 99.9995%.

The new product design allows clients, requiring lower flows with high nitrogen purities (e.g., chemical labs, electronics industries), to utilize less space and reduces installation time. Air and nitrogen buffer tanks are integrated on a common skid, and patented piping and separation materials optimize the PSA process and pressure drop. "PSA technology has been around since the 1970s, but Generon specializes in packaging the technology for various applications," said Jeffers.

### How the PSA Process Works

The PSA process achieves continuous production of nitrogen through adsorption, regeneration and repressurization. During the adsorption phase, pressurized air from a compressor is forced into the bottom of one of the twin towers and through the bed of carbon molecular sieve (CMS). As this tower is pressurized, oxygen molecules are adsorbed onto the face of the CMS, and nitrogen molecules flow out the top. During the adsorption phase in the first tower, regeneration

## Sterile Compressed Air

is a critical part of the food packaging process,

**Domnick microBAN** manufacturers filter housings which will meet and exceed your most stringent specifications.



- Superior operating performance
- Manufactured to the highest quality standards
- 100% integrity tested
- Over 25 years in the critical filtration industry
- Full technical, sales and service support
- Replacement cartridges for all makes of filter housings are guaranteed to provide equal to or better performance than the original equipment

*For a special offer please reference DMB0910CABP when you call us to place an order.*

## Domnick microBAN

micro filtration products

[www.domnickmicroban.com](http://www.domnickmicroban.com)

Toll Free: (877) 366-6425

E-mail: [info@domnickmicroban.com](mailto:info@domnickmicroban.com)

### Products by Generon IGS

**Oxygen Generators:** Generon's Oxyswing® PSA generators, designed for heavy-duty operation, are available in twin-tower or modular-type models and can produce oxygen purities up to 99.9995% (with De-Oxo option), meeting a wide range of flows, purities, and pressures. The PSA process for oxygen generation mirrors that of nitrogen but utilizes CMS instead of zeolite (aluminosilicate material). For medical applications, the European Medical Device Directive 93/42/EC (equivalent to the FDA) has approved the Generon® Medical Oxygen PSA Generator. These also can be used as compact, turnkey portable field hospital units that can be configured on a single skid or installed in an ISO transport container.

**Instrument Air Packages:** Generon's compact instrument air packages can be unitized with primary air compression to reduce size, installation cost, and time. Also available are standard twin tower desiccant dryer instrument air packages and standard or individualized skidded membrane instrument air packages. Standard systems are designed for non-hazardous applications and can be integrated with patented Generon® Nitrogen Membrane systems. Multiple communication software is available.

**Gas Compression Packages:** Generon IGS is an authorized packager for all the major gas compression manufacturers: primary compression (CompAir, Sullair, IR, GD, LeROI), and post-compression (Ariel, Hurricane, General Electric, Revell, LeROI). Systems are configured to custom specifications to meet all operating conditions and load capacities.

## THE TECHNOLOGY PROVIDER

### Nitrogen Solutions for the Food Industry Generated on Location



The Controls Cabinet of the Compact PSA System Nitrogen Generator

occurs in the second tower, depressurizing and releasing adsorbed oxygen through the vent line. The repressurization phase starts during the next cycle. The system offers input pressures up to 145 psig (10 barg), output pressures up to 120 psig (8.3 barg), flows up to 3300 scfh (86.8 Nm<sup>3</sup>/hr), and purities from 95% up to 99.999%. “The PSA technology is better suited for applications that require nitrogen purities of 99% or higher”, said Jeffers. “The adsorption properties of the specially treated CMS permit efficient nitrogen production by charging two alternatively used adsorber vessels with compressed air,” said Jeffers. “While one vessel adsorbs, the other regenerates by pressure reduction. IGS has developed a proprietary mix of cycle timing and molecular sieve types to reach desired purity at maximum efficiency.”

### Nitrogen Applications in the Food Industry

Use of nitrogen as a food preservative is gaining widespread acceptance as a non-chemical method of food preservation, as it can improve the quality and expand the availability of perishable commodities and leaves no chemical residues. In addition to preservation, compact nitrogen PSA generators have multiple applications in the food packaging industry, including packaging, fluffing, and head space replacement; controlled atmosphere storage and oxidation control of perishable foodstuffs; sparging of liquids/wines; blanketing of process operations to prevent combustion; beer dispensing; purging tanks and vessels; and pest control and fumigation.

### Storage

Nitrogen does not react with elements around it and can be used to displace oxygen inside produce storage facilities, where it slows the ripening process. “Bananas are stored inside ISO containers for months before they ever reach your table,” said Jeffers. “Nitrogen slows down the ripening process and allows the fruit to remain viable during the transport process.” Generon’s nitrogen PSA generators are adjustable to achieve specified gas purity levels for various products; the ideal atmosphere for storage of vegetables and fruits is within the 95% to 99% purity range. The process also displaces the carbon dioxide produced by respiration of produce in storage space. Generon’s nitrogen-generating, hollow-fiber membrane technology also can create optimum atmospheric compositions for controlled atmosphere storage. Apples, bananas, kiwi, asparagus, blueberries, onions, and fresh cut flowers can be stored sometimes as long as one year.



**“Operating costs are crucial when evaluating system payback, and energy costs comprise the main portion of these. Generon IGS is offering a solution to save time, space, and money — generate the nitrogen onsite for easy and efficient use.”**

— Tom Jeffers, President of Houston, Texas-based Generon Innovative Gas Systems (IGS) US



## Packaging

To prevent oxidation and spoilage of raw food ingredients, nitrogen is used inside food packaging to achieve a meaningful shelf-life extension. Almost every type of packaged food can thrive in a 99% pure nitrogen atmosphere, including chips, meat snacks, peanuts, and other snack foods which contain oxygen-sensitive oils. By using 99% gaseous nitrogen in the processing and packaging of coffee, the oxidation of flavorful oils is minimized, extending the shelf life and increasing profitability for the merchant and retailer. Food liquids can also benefit from the use of nitrogen. Purging the headspace between the liquid and the lid of bottles and containers and substituting with nitrogen can extend shelf life as much as 500%. Fruit juices may require 99.5% pure nitrogen, while many wineries use 99% pure nitrogen not only to purge the headspace but to purge the entire bottle before it is filled. Even bird seed is sometimes packaged with nitrogen.

## Pest Control and Fumigation

In addition to its preservative qualities, nitrogen also has the capability to kill insects that eat grain. Nitrogen as a de-infestation chemical is gaining popularity as government regulators seek alternatives to ozone-depleting insecticides. Recent increases in sales of organic fruits, vegetables, and grains show that consumers also are becoming more aware of the dangers of chemical ingestion. "Farms are replacing air with nitrogen in silos to deter rodent infestation, and these types of uses of nitrogen are potentially a very large business," said Jeffers. "We are still uncovering the many useful applications of nitrogen in various industries." **BP**

*For more information please contact Generon Innovative Gas Systems, tel: 713-937-5200, [www.igs-global.com](http://www.igs-global.com).*

# Sullivan Palatek®

**Our Systems have the BRAINS  
to effectively and efficiently  
operate the compressors  
throughout your facilities!**

**BECAUSE REAL-TIME AIR INTELLIGENCE IS NECESSARY TO SYNCHRONIZE YOUR FACILITY!**



## MetaCenter

**Compressed Air Management System  
Easy To Use, Visual Software  
Site Systems Integration**

**Save Energy  
Ultimate Drive Reliability  
Communicating Controls  
Easy Ramp Up Saves Energy**



## Variable Frequency Drive (VFD)

1201 W US Hwy 20  
Michigan City, IN 46360

800-438-6203  
219-874-2497

[www.sullivanpalatek.com](http://www.sullivanpalatek.com)  
[info@palatek.com](mailto:info@palatek.com)

# CYCLING REFRIGERATED AIR DRYERS — ARE SAVINGS SIGNIFICANT?

BY TIMOTHY J. FOX AND RON MARSHALL  
FOR THE COMPRESSED AIR CHALLENGE®



One of the many tasks in assessing a compressed air system supply side is to analyze the air treatment system for appropriateness and efficiency. Most compressed air systems have one or more air dryers in place to remove the water vapor contained in the compressed air produced by the system air compressors. If there is no air dryer, the normally hot saturated air produced by the air compressors will cool in downstream system components, and condensed water will form in pressurized system pipework. This water may contaminate downstream air-powered tools and production machinery with rust, oil and pipe debris. Refrigerated style dryers are typically used in industrial plants to process general industrial compressed air that would be used by tools and pneumatic machinery. There are different modes of operation for

refrigerated dryers that have different energy implications, especially when the dryers are subject to partial heat and moisture loading. In order to make a good choice in terms of energy efficiency, the purchaser should take care in understanding the operating characteristics of the different refrigerated dryer options available.

Air compressors consume the majority of the power required by a compressed air system; a well running system requiring between 18 and 22 kW of energy input per 100 scfm of air produced at a compressor discharge pressure of about 100 psig (kW/100 cfm is called specific power). Fully loaded refrigerated air dryer specific power levels range between 0.6 and 0.8 kW per 100 scfm, or about 3 to 4% of the total system power.



Like air compressors, when dryers run at partial loading, the specific power of a dryer increases, reducing the efficiency of the treatment system. This effect can be seen if the CAGI data is analyzed for a given size of air dryer.

**Fundamentals of Compressed Air Systems WE (web-edition)**



Join us for the next session of *Fundamentals of Compressed Air Systems WE* (web-edition) coming November 9th. Led by our experienced instructors, this web-based version of the popular *Fundamentals of Compressed Air Systems* training uses an interactive format that enables the instructor to diagram examples, give pop quizzes and answer students' questions in real time. Participation is limited to 25 students. Please visit [www.compressedairchallenge.org](http://www.compressedairchallenge.org), to access online registration and for more information about the training.

If you have additional questions about the new web-based training or other CAC® training opportunities, please contact the CAC® at [info@compressedairchallenge.org](mailto:info@compressedairchallenge.org).

Like air compressors, when dryers run at partial loading, the specific power of a dryer increases, reducing the efficiency of the treatment system. This effect can be seen if the CAGI data is analyzed for a given size of air dryer. For example, a 1000 scfm unit using a hot gas bypass system to control its drying capacity might start off at a specific power of 0.7 kW/100 scfm, but have its specific power fall to 5.36 kW/100 scfm at 10% loading. A thermal mass style of dryer, on the other hand, may start out at 0.73 kW and have a less pronounced efficiency decrease at lighter loads, with a final specific power of 1.67 kW/100 scfm at 10% loading.

**Example Savings Calculation**

Consider a system with two 500 scfm, 100 psig rated air compressors, one spare and one backup, arranged using a single 1000 cfm air dryer. The system was sized for future capacity. Average flow produced by the running compressor is 225 scfm with peaks to 425 scfm. A variable speed air compressor was chosen to optimize the efficiency of the system at part load. The rating of the compressor at part load is 20.3 kW per 100 scfm as per the CAGI sheets. Power consumption of the compressor would be 45.7 kW. If a non-cycling air dryer is selected, the dryer consumption at the average 22.5% of rated flow conditions would be about 81% of full load, or 4.94 kW. This equates to 11% of the compressor power. If a digital scroll, thermal mass or cycling dryer was chosen, the dryer power would reduce to levels accounting for only 2 to 4% of the air compressor power.

**TABLE 1: SELECTED REFRIGERATED DRYER CAGI DATA**

ITEM	STYLE	FULL FLOW SPECIFIC POWER (KW/100 SCFM)	10% FLOW SPECIFIC POWER (KW/100 SCFM)	FULL FLOW PRESSURE DROP (PSID)	10% FLOW PRESSURE DROP (PSID)
Brand A	HG Bypass	0.61	5.36	4.8	< 0.10
Brand B	HG Bypass	0.74	7.22	2.5	0.33
Brand B	T Mass	0.89	1.10	2.5	0.33
Brand C	T Mass	0.73	1.67	2.1	0.10
Brand D	Cycling	0.45	1.43	2.1	0.04
Brand E	VSD	0.70	3.01	3.0	0.05
Brand A	D Scroll	0.67	2.00	4.8	0.10

# CYCLING REFRIGERATED AIR DRYERS – ARE SAVINGS SIGNIFICANT?

## Refrigerated Dryers Styles Explained

Refrigerated compressed air dryers have been used for many years as a cost effective and energy efficient solution for eliminating moisture from compressed air systems. These 39 °F (3 °C) to 45 °F (7 °C) pressure dew point machines are well-established and industry proven. Most designs operate the refrigeration compressor continuously and are termed “non-cycling”, utilizing a hot gas bypass valve to redirect refrigerant around the expansion device and into the suction line at less than full load conditions. See Figure 1. When designed correctly, these machines offer stable outlet pressure dew points and long refrigeration compressor reliability. Regardless of the air load coming into the dryer, the energy consumption is nearly the same as the full load (rated) value. This is illustrated in Figure 2.

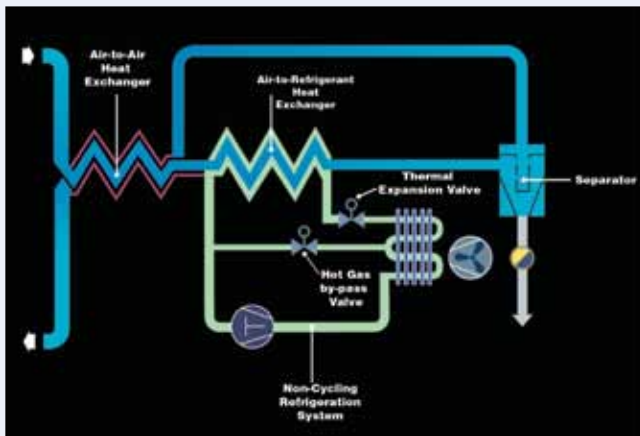

Figure 1. Non-Cycling Refrigerated Dryer Source: SPX

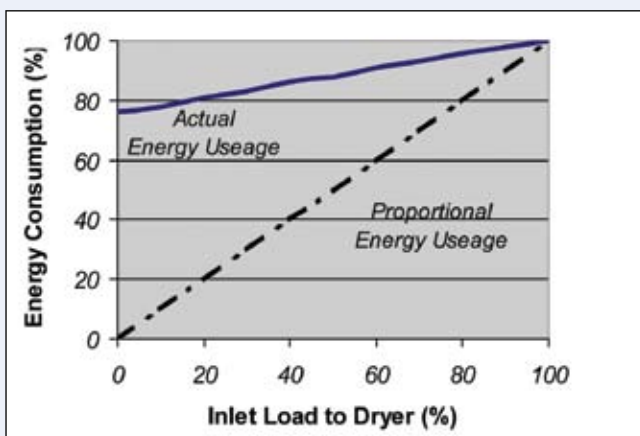

Figure 2. Energy Consumption in a Non-Cycling Refrigerated Dryer Source: SPX

## Additional Savings Due to Lower Inlet Temperature

Often in temperate climates, especially in winter months, or where air compressors are cooled with a cold water supply, the inlet temperature to the air dryer is significantly less than rated conditions. Consider a dryer that is seeing full flow, but its inlet air is only 80 °F rather than 100 °F. This reduction in temperature and moisture content will reduce the heat load on the air dryer by 38% causing the energy consumption of the dryer to fall in the same manner as a 38% reduction of flow.

## Pressure Differential Savings

The pressure differential across the air dryer has an effect on the power consumed by the air compressor. For a given desired plant pressure, the compressors must be set at a higher discharge pressure to compensate for pressure loss. At 100 psig, air compressors consume about 1% more for every 2 psig in increased discharge pressure. For example, at full flow a pressure differential of 2.1 psid rather than 4.8 psid would cause the air compressors to consume about 1.3% less. This savings relationship does not hold true for partial loading because the pressure differential across the dryer varies with the square of the flow. For the previous example of a dryer at 22.5% rated flow the difference in resulting pressure differential would be reduced to negligible (0.1 psid vs .24 psid).

The pressure differential across air dryers and associated filters can greatly affect the operation of load/unload compressors if the majority of system storage is on the down steam side of the dryer. For example, for a system with system storage of 5 gallons per cfm capacity and a compressor load/unload pressure band of 10 psi, a 4.8 psid dryer differential plus a 3 psid filter differential would result in an *effective* storage equivalent of 1.1 gallons per cfm. This would increase the compressor cycle frequency by over 4 times that of a 5 gallon per cfm effective storage value. Increased cycle frequency will cause reduced compressor efficiency. For a 100 horsepower load / unload compressor running at 45% capacity, this would increase power consumption by about 18%.

## Other Dryer Savings Measures

- Ambient dewpoint tracking — the dryer control adjusts the dewpoint of the processed air to a set differential from ambient

- **Timer shutdown** — Shuts down the operation of the dryer on a time schedule during periods where no production is running in the plant and the air compressors are off
- **Low flow shutdown** — the dryer refrigeration system is shut down when zero flow conditions exist

### Three Energy-Saving Refrigerated Dryer Styles

As the demand for energy efficient equipment continues to grow, refrigerated dryer manufacturers are being challenged to provide “load matching” equipment that will consume less energy as the incoming load to the dryer is reduced. Three styles of energy saving refrigerated dryers are currently available: the thermal mass cycling, the variable speed and digital scroll style dryer. These designs offer some level of energy savings when compared to the non-cycling units. However, each has varying performance characteristics.

### Cycling Dryers

The most common type of energy saving refrigerated dryer marketed today is the thermal mass, or cycling dryer. In this design, a thermal storage medium, either a liquid or a solid, is used to store cooling capacity whenever the inlet conditions to the dryer are less than the full load conditions. The excess refrigeration capacity that is not needed to cool the compressed air is used to cool the storage medium. Once the mass has been chilled to a pre-determined temperature, a thermal switch turns the refrigeration compressor off. The air is now dried solely by the thermal medium. After this material warms up, the thermal switch activates and restarts the refrigeration compressor.

Care must be taken to design enough storage capacity so as to limit the start/stop events of the compressor to no more than eight (8) per hour, as recommended by the compressor manufacturer. Cycling the compressor more than this can limit its life and reliability. For larger dryers, the required amount of storage medium is substantial, resulting

## Don't let anything but Omnilube® near your food line.

*No other food-grade lubricant combines this degree of process purity with Ultrachem's renowned base oil & additive technology.*

Choose Omnilube® for:

- higher performance
- longer life
- greater efficiency
- lower maintenance
- less environmental impact

Plus Ultrachem's unparalleled technical expertise and customer support.

**Omnilube® by Ultrachem.**  
**For Superior Synthetic Lubrication.**



  
**ULTRACHEM INC**  
PREMIUM SYNTHETIC LUBRICANTS  
www.ultracheminc.com • 302-325-9880



## CYCLING REFRIGERATED AIR DRYERS – ARE SAVINGS SIGNIFICANT?

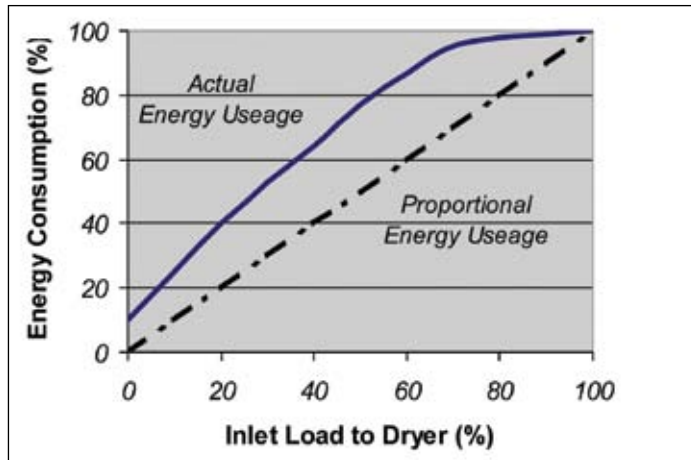

Figure 3. Energy Consumption in a Thermal Mass Refrigerated Dryer Source: SPX

in larger and heavier dryers. Cycling dryers may show a typical dew point swing because the refrigeration system is turned on and off within a set temperature band chosen to limit the refrigeration compressor starts and stops yet keep the dewpoint of the output air at acceptable levels. Thermal mass dryers may lack the ability to closely match the actual heat load placed on the dryer with the actual energy consumed by the machine. Test results show that many thermal mass dryers will not begin to cycle until the load on the dryer reaches 75% or less than its rated capacity. Figure 3 displays measured values for energy consumption in a typical cycling dryer.

### Variable Speed Dryers

Another entry into the energy savings dryer market is the variable speed refrigerated dryer. This design capitalizes on the recent advances in power conditioning technology to apply newer, cost-effective variable frequency drives to traditional refrigerated dryers. These drives raise and lower the frequency of the electrical power to the refrigeration compressor in order to increase and decrease the speed of the compressor motor. By changing the speed, the refrigeration capacity of the compressor is altered in direct

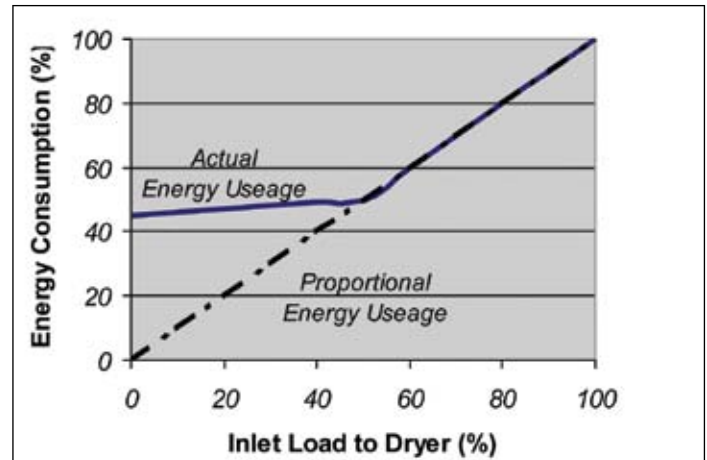

Figure 4. Energy Consumption in a Variable Speed Refrigerated Dryer Source: SPX

proportion. This is done in order to match the cooling requirements of the incoming air. By decreasing the speed, the power consumed by the compressor is also decreased. The monitoring of the refrigeration suction pressure or the compressed air temperature provides the input to the frequency drive control.

The control of these dryers is fairly complex, with higher initial cost. Due to lubrication requirements of the refrigerant compressor, the compressor motor can only turn down to 50% of the rated capacity. Turn down ratios can be improved by using smaller compressors and over-spinning (operating at frequencies > 60 Hz) the compressor at full load conditions. The complexity of these VSD controlled units sometimes poses a challenge to refrigeration technicians who are not skilled in electronic troubleshooting.

These units show linear turndown of power consumption for the top half of their capacity, but for inlet heat loads below 50%, the VSD designs activate a typical hot gas bypass valve and the dryer behaves as a non-cycling design. See Figure 4 for energy consumption as a function of inlet load for a variable speed dryer.



**Three styles of energy saving refrigerated dryers are currently available: the thermal mass cycling, the variable speed and digital scroll style dryer. These designs offer some level of energy savings when compared to the non-cycling units. However, each has varying performance characteristics.**

### The Digital Scroll Dryer

The digital scroll refrigerated dryer shows excellent load matching energy savings. The evaporator design is similar to non-cycling dryers, utilizing a direct expansion refrigerant-to-air heat exchanger, providing a thermal system that is more responsive than a cycling dryer. This evaporator is constructed so that the air temperature leaving the heat exchanger remains nearly constant as the load profiles vary, even down to a no load condition.

The system control consists of a microprocessor-based controller that computes the required changes in refrigeration capacity using a PID (proportional-plus-integral-plus-derivative) style control loop.

These dryers use a digital scroll compressor that operates by using two mating scroll cavities. One of these halves is fixed; the other half mates to the fixed cavity and orbits around it. The scroll surfaces form pockets of compression that become smaller as the gas moves from the outer edge of the scroll set towards the center discharge port. These decreasing pockets create the necessary compression. There are no valves in the compression chamber and only two moving parts.

The compressor is tolerant to the ingestion of liquid and solid debris through its ability to be “compliant” along two degrees of freedom — radially and axially. “Compliance” means that the scroll set can separate briefly in the presence of a non-compressible substance, and the liquid or solid contaminant can pass through the compressor. The set then moves back to its original position and resumes the compression process. Compliance increases the durability of the compressor dramatically.

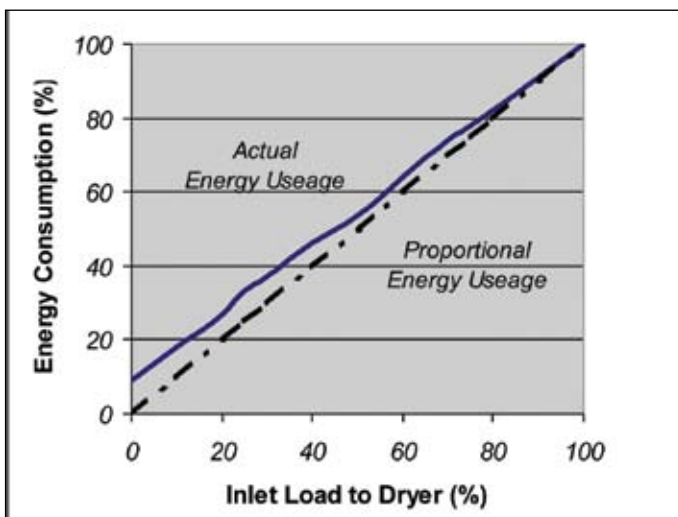

Figure 6. Energy Consumption in a Digital Scroll Refrigerated Dryer Source: SPX

The power to save energy  
is at *your* fingertips.

[savewithgardnerdenver.com](http://savewithgardnerdenver.com)



Compressed Air Solutions

## CYCLING REFRIGERATED AIR DRYERS – ARE SAVINGS SIGNIFICANT?

### CAC® Board Member Profile

**Timothy J. Fox, P.E.**

Manager, Research and Development  
SPX Flow Technology  
1000 Philadelphia Street  
Canonsburg, PA 15370

Tel: +1 724-873-8443

Mob: +1 412-427-9448

Fax: +1 724-745-6040

Email: tim.fox@spx.com



- Over 25 years of experience in the compressed gas dehydration and filtration industry
- Vice President of the Compressed Air Challenge (CAC)
- Current board member of Compressed Air and Gas Institute (CAGI)

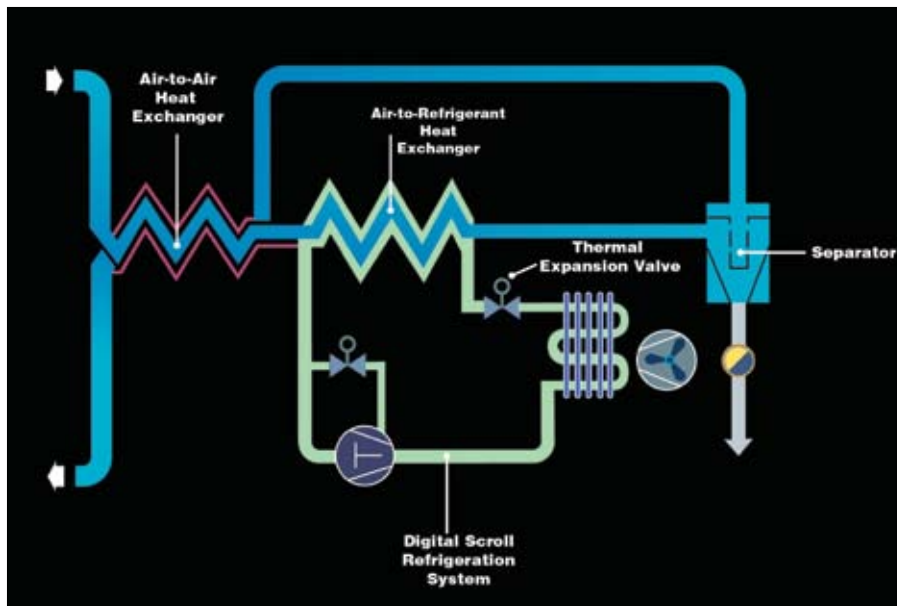

Figure 7. Digital Scroll Refrigerated Dryer Source: SPX

It is the axial compliance portion of the design that allows these compressors to be digitally modulated. By separating the scroll halves axially on demand, the compression of the gas can be interrupted on demand. The axial separation of the scroll halves is achieved by relieving the pressure on top of the fixed scroll half and porting it to the suction line through a small solenoid. When the solenoid is energized, the gas escapes and separates the scroll set. Once the gas compression is stopped, the flow of refrigerant from the compressor is also stopped; no work is done on the refrigerant and there is no refrigeration capacity in the system. Thus, the term digital refers to the system either having full capacity or no capacity.

When the compressor is unloaded (no refrigeration capacity), there is no shaft work being performed by the motor. The motor, however, does continue to rotate at its normal speed. The “unloaded” motor consumes some electrical power, approximately 10% of its fully loaded value, but the constant rotation of the motor shaft assures that the oil lubrication required by the internal bearing surfaces is adequately and continuously supplied.

Since the power consumed by the compressor is reduced significantly during periods of unloading, the average power consumed by the dryer can be reduced proportionately to match the load. See Figure 6.

Testing has shown that the system is capable of maintaining very stable dewpoint output through full range of operation rated full load down to a no load condition. The use of a hot gas bypass valve is completely eliminated, resulting in a simple refrigeration circuit. Figure 7 shows a process diagram of the Digital Scroll Dryer. **BP**





# SUSTAINABILITY PROJECTS FOR INDUSTRIAL ENERGY SAVINGS

## Cut Costs and Stay Competitive with Advanced Energy Management

BY BOB ZAK, POWERIT SOLUTIONS

With the economy still challenging and competitive pressures continuing to rise, reducing expenses is imperative for food processing and other manufacturing businesses. Yet many underestimate or neglect a key source of savings: the electricity bill.

You may be wise to watching the demand meter or shifting heavy loads to off-peak hours, but those are not your only options. With advanced energy management technology, you can automate control of energy from refrigeration compressors, pumps, and other equipment so that your facility runs at optimal efficiency, you pay the lowest possible rates, and you can participate in incentive programs that pay *you* for unused kilowatts.

Even the most energy-intensive plants can cut energy costs without compromising production or quality. The key is to take full advantage of the load-shedding strategies that an advanced energy management system enables: demand control, demand response, dynamic pricing optimization, and energy efficiency.

### Energy Cost Reduction Strategies In Brief

**Demand control:** Demand control (DC) is a strategy that allows food processors and other manufacturers to use energy more efficiently by managing peaks and valleys of energy demand. An advanced energy management system (EMS) allows you to do this safely by strategically directing demand reductions through a collection of selected compressor and other loads to achieve the desired kW reduction while maintaining productivity. Actions the system might take include:

- Slow down or cycle fans and blowers (or raise the temperature setpoint in a cooled area) to reduce kilowatt load from exhaust fans, refrigeration compressors, and condensers, for example
- Apply slight changes in suction pressure to reduce the load from refrigeration compressor motors
- Curtail nitrogen system compressor motors



Panel view of the Spara EMS in the main electrical control room at Four Star Fruit

Full facility monitoring and control is available from this panel, or via any network-connected computer with appropriate permissions.

- Reduce wastewater treatment loads to minimize consumption by blowers, agitators, and pumps
- Shut down battery chargers
- Delay the start of vacuum tubes or grinders

The savings can be significant: peak-time energy use can account for as much as 40% of an industrial user's electricity bill; avoiding these spikes can reduce the overall bill by as much as 15%.

Food processors often wonder how it's possible to do this without losing production capacity. The answer is that an advanced EMS can adjust loads quickly and precisely throughout the facility (not just on, say, refrigeration equipment), so you get maximum savings with minimum disruption.



# SUSTAINABILITY PROJECTS FOR INDUSTRIAL ENERGY SAVINGS

## Cut Costs and Stay Competitive with Advanced Energy Management



**Demand Response configuration screen in Spara View**

SparaView is connected to the aggregator's Auto DR server and SCE's demand response automation server. Four Star's Spara EMS implementation is configured to automatically pre-cool grape storage rooms before the DR event, and Spara has the process knowledge to protect products during the event.

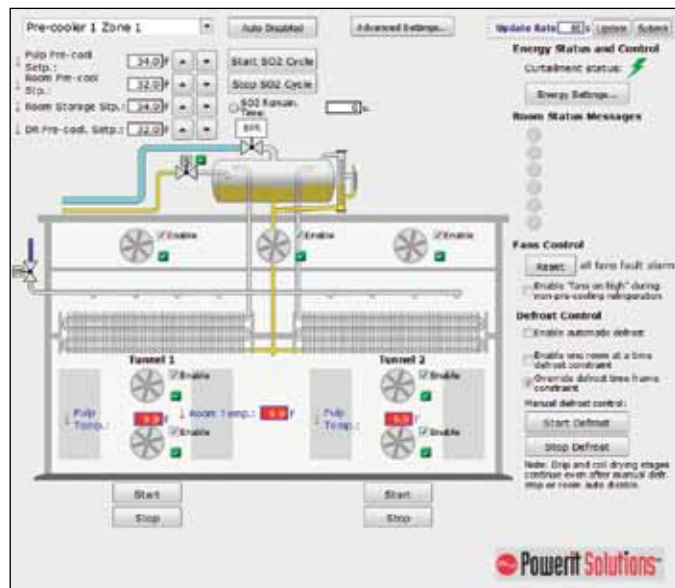

**Controls for Pre-cooler 1**

This is one of 15 rooms Spara EMS automates for demand control and demand response. Spara EMS is designed to balance DR and EE with the operational requirements of the facility. The Spara system integrates with a host of industrial processes and loads, including those in food processing facilities, to plug energy-intensive businesses into the smart grid.

An advanced system can prioritize loads sequentially, by group, or by other factors, and it can synchronize load shedding to achieve both savings and productivity targets. This level of control and precision is impossible for most facilities to achieve manually or with disparate automation systems.

For example, at Mission Produce in Oxnard, California, Powerit's Spara system rapidly tracks dynamic operating conditions and adjusts power loads, sometimes for just minutes. The system controls evaporator and condenser fans via variable frequency drives (VFDs), five refrigeration compressors in two locations, and battery chargers. Since system implementation, the company has reduced its peak-load energy use and monthly energy bills by about one-third. The company has set rules in the system to protect production — the EMS never takes curtailment actions beyond the levels specified.

**Demand response:** This is a demand reduction strategy being implemented by utilities and power system operators across the country. Demand response (DR) programs let you earn money by curtailing your electricity use on demand. For example, on an unusually hot summer day a utility might notify demand response participants that it needs them to curtail their usage by an amount specified in their participation contract.

There are two types of DR programs: In standby/reliability programs, you commit to specific load reductions when the grid is under stress. These infrequent events often last two to four hours. Prices are usually \$30,000 to \$60,000 per MW. In reserves/market-based programs, you agree to cut usage based on a set price. Events are more frequent than standby/reliability events and usually last one hour or less. Prices are typically about \$40,000 per MW.

Automated demand response (Auto-DR) programs tend to be the most lucrative programs. Advanced technology is essential for participation, however: new and upcoming programs require automated communications between user and supplier systems, along with quicker, more significant responses. In these programs, a business's system and the utility or grid operator's system "talk" with each other using the OpenADR (automated demand response) standard. A Smart DRAS (demand response automation server) client provides a dynamic connection. For example, with Powerit's Spara EMS, the supplier's system notifies the user's system of a demand response event, and Spara takes action according to energy usage rules set for that facility. Users can also set multiple electricity pricing levels where they want to respond with predefined actions.

Even with non-automated DR programs, though, many food processors find participation impossible without an advanced EMS. Mission Produce tried it, but found that manually shutting down system components took too long to be effective and the staff lacked the ability to fine-tune the entire system for ramp-up. It's now able to earn incentive payments through Southern California Edison's program.

**Dynamic pricing optimization:** Many utilities employ dynamic pricing strategies, such as real-time pricing (RTP), that involve rate changes based on the market price of electricity, weather events, or other conditions. These changes can happen with anywhere from just minutes' to 24 hours' notice, and in worst-case examples, power costs have jumped during an RTP spike to more than 100 times the normal rate. An advanced EMS lets you respond automatically to ongoing price fluctuations by shifting consumption to lower rate periods or reducing consumption during costly super-peak times.

**Energy efficiency:** Energy efficiency — not only using less energy, but also using energy at the least costly times — is often a byproduct of implementing demand control, demand response, and dynamic pricing programs. These initiatives typically reveal best-practice opportunities for eliminating waste and optimizing use.

Measures might include:

- Floating head pressure control that leverages variable speed controls on fan motors, minimizing refrigeration compressor and condenser system motor loads by matching operations to particular cooling processes and ambient wet-bulb temperatures



## AFE Membership Is Essential to Your Career Development

# The Facilities Professional's Toolkit for **SUCCESS**

> CAREER-FOCUSED NETWORKING > EDUCATION AND CERTIFICATION > INDUSTRY NEWS AND INFORMATION

JOIN AT: [www.AFE.org](http://www.AFE.org), or complete the application below and

FAX TO: (571) 766-2142 • MAIL TO: AFE, 12801 Worldgate Drive, Suite 500 Herndon, Virginia, 20170

Mr. /  Ms. Name \_\_\_\_\_ Nickname \_\_\_\_\_  
 Date of Birth \_\_\_\_\_ Job title \_\_\_\_\_  
 Preferred Mailing Address: Street \_\_\_\_\_  
 City \_\_\_\_\_ State \_\_\_\_\_ Zip \_\_\_\_\_  
 Phone \_\_\_\_\_ Preferred email: \_\_\_\_\_

**DUES (This membership is individual and non-transferable)**

**Special Promotional Dues Rate \$199.00**

Special membership promotion is available to new and former members. Hurry! Offer expires June 30, 2011.

Payment Method:  Check enclosed  Credit card:  Visa  MasterCard  American Express

Account # \_\_\_\_\_ Expiration Date \_\_\_\_\_

Name on card \_\_\_\_\_ Signature \_\_\_\_\_

FOR FURTHER INFORMATION visit [www.afe.org/benefits](http://www.afe.org/benefits) or contact Maxine McIntosh at 571-203-7236 (email: [MMcIntosh@afe.org](mailto:MMcIntosh@afe.org)).

**AFE** Association for FACILITIES ENGINEERING.

# SUSTAINABILITY PROJECTS FOR INDUSTRIAL ENERGY SAVINGS

## Cut Costs and Stay Competitive with Advanced Energy Management

- Automated staging and sequencing of air compressor combinations so that compressors in use are fully loaded before additional capacity kicks in
- Precisely and dynamically aligning air handling fan speeds and airflow with real-time temperature requirements

- Matching evaporator defrosting cycles to actual needs instead of operating on inefficient schedule-based routines

### Produce Processor Cuts Energy Costs Using DR, Other Energy Management Strategies

Only a small fraction of food processing businesses takes advantage of these prime saving opportunities, but the few that do demonstrate the potential. For example, Four Star Fruit of Delano, California, uses Powerit Solutions' Spara EMS to implement demand control, Auto-DR, and energy efficiency measures that combined save the company 16% annually on its electricity bill.

Four Star uses a very large amount of electricity during three critical months of the year, and its business is growing. In the 36 months preceding the implementation of its energy management system, the business grew in the double digits while its power consumption doubled. The company wanted to better control its energy use, in light of a predicted rise in power prices over the next several years, and to improve its "green" credentials.

Facilities like Four Star's offer good potential for both DR and DC strategies: the facility can precool and flywheel cool in anticipation of a DR event, or use temperature buffers to ride out a DC event. In this case:

- The combination of precooling rooms and long-term storage rooms provides loads that can be balanced against one another
- Precooling rooms can be loaded with produce all day, and then precooled in the evening
- Long-term storage rooms can be flywheeled, cooling them in advance so that their refrigeration can be powered down when precooling needs occur

The type of facility (precooling combined with long-term storage) made the company a good candidate for an Auto-DR program.

### Why Advanced Automation Is Essential — And How to Assess It

Manually manipulating complex processes to achieve energy savings is difficult to impossible for most companies. It can also introduce human error and potentially compromise production. And the scope and types of loads that can be shed using manual approaches are limited, making participation in DR programs or response to dynamic pricing impossible or unprofitable. An advanced EMS is essential to getting full value from the spectrum of load-shedding strategies.

Key features of the best energy management systems are:

- Ability to take direct control of the loads — within parameters you set—so that no human intervention is required
- Seamless integration with existing systems and the ability to extend their functionality
- Capacity to connect with many loads in order to take maximum advantage of potential savings

- Access to real-time data in order to analyze and predict events
- Rules-driven, process-protecting routines tailored to your operations that can manage an infinite variety of industrial processes, limitations, and thresholds
- Wireless input/output, which eliminates the need to run costly conduit (often a disruptive and time-consuming process) and provides access to hard-to-reach places, ensuring that the maximum number of equipment loads can be controlled

Beyond the technology itself, look for a vendor that can assist in identifying and evaluating utility programs, rebates, and incentives. The vendor should also have expertise in your industry, so that they're familiar with typical processes and equipment and can share best practices based on past projects.



# FREE SUBSCRIPTION

DIGITAL EDITION FREE WORLDWIDE | PRINT EDITION FREE TO U.S. SUBSCRIBERS



## COMPRESSED AIR BEST PRACTICES

Learn How To Save Energy & Improve  
Productivity In YOUR Industry!

### 2011 FOCUS INDUSTRIES:

- Concrete Bulk Handling
- Lumber, Pulp & Paper
- Wastewater Treatment
- Pharmaceutical
- System Assessments
- Food Processing
- Automotive Manufacturing
- Plastics Blow Molding
- Air Compressor Controls & Monitoring
- Food Packaging

Subscribe at [www.airbestpractices.com](http://www.airbestpractices.com)

International pricing for print edition — \$65 in Canada and \$95 for other countries.

# SUSTAINABILITY PROJECTS FOR INDUSTRIAL ENERGY SAVINGS

## Cut Costs and Stay Competitive with Advanced Energy Management



Four Star's EMS integrates with demand response automated servers (DRAS) operated by its utility, (Southern California Edison) and demand response aggregator (EnerNoc). The company participated in both DR events called by the last season, achieving a load reduction near to their test demonstration reduction of 700kW.

### System Assessment: A Key First Step

So how do you determine whether your facility can realize these types of savings? A thorough assessment of your production systems is a key first step. Here's the process my company follows when conducting assessments:

**Define the savings opportunities.** We do this by analyzing electric bills and historical kW interval data and evaluating opportunities to participate in demand response or other incentives programs.

**Create a data picture of the facility.** We collect detailed data about the facility's main processes, largest electrical loads, and the facility in general.

**Perform a site audit.** The audit covers the entire facility and all processes, from receiving raw materials to final product shipping. Because the largest electrical loads provide the best ROI for automation investment, those loads are analyzed in detail. We look at current standard operating procedures, typical run time, time of use, and loads, and evaluate those areas for inefficiencies.

Savings can come from multiple initiatives. In general, if a load has a process buffer (the output of the load is stored until a maximum point is reached, then the load is turned off until the minimum point is reached), cost savings opportunities exist. The load can be turned off or slowed down when energy costs are high, for example. By studying the entire process and identifying these buffers within batch or continuous

processes, we typically find opportunities for energy cost reductions via demand control, demand response, energy efficiency, or all three.

**Finalize the evaluation.** Based on the results of data collection and the site audit, the initial savings estimate is revised to correct any mistaken assumptions and reflect actual savings potential.

### Advanced Energy Management At Work: A Real-World Example

Here's an example of a typical demand control operation at a food processing facility that's controlling energy demand using Powerit's Spara EMS:

1. The EMS's real-time algorithm predicts that the facility's current energy use will exceed its setpoint by x kW. The facility needs to shed loads
  2. The system determines which refrigeration compressors are enabled for reduction at this moment. These loads are available for curtailment
  3. The EMS stages curtailment actions based on the preferred order that's been set in the system. Compressor A and Compressor B have a priority of 1 and 2. Compressor A has x kW safely available for reduction, so the system powers it down accordingly. It then powers Compressor B down x kW to get the remaining reduction needed
  4. Each compressor can operate at reduced power for only so long without disrupting operations, and that time has been set in the system. The EMS monitors the reduction time and sees that Compressor A has hit that point. It releases Compressor A and further reduces Compressor B to get the rest of reduction needed
- Note:* Time as a constraint is a simple example of a rule that can be integrated into the system's decision-making process. Rules can also be fairly complicated and logic based (if pump speed is X and tank level is Y then the agitator can be curtailed to speed Z) or triggered by schedules or production factors
5. Now you've hit your goal. All loads are released according to the procedure set by the facility



**Four Star Fruit of Delano, California, uses Powerit Solutions' Spara EMS to implement demand control, Auto-DR, and energy efficiency measures that combined save the company 16% annually on its electricity bill.**

What happened here? The facility's processes were interrupted, but they weren't *disrupted*. The changes were defined in advance as acceptable power reductions in return for energy savings.

Food processors can significantly reduce previously uncontrollable energy costs. By being able to aggressively manage a monopoly-controlled resource that continues to rise in cost year over year, you can not only cut costs, but also gain competitive advantage.

### Fitting the Investment Into Tight Budgets

The investment in an advanced EMS is more manageable than many facility operators expect. Depending on incentives available in your area and your implementation, it's possible to achieve ROI anywhere from immediately to 18 months.

Many utilities offer incentive programs that cover partial or even full costs of systems designed to reduce energy consumption or manage peak demand. These incentives cover a wide variety of equipment and technology for applications ranging from basic energy efficiency to automating participation in demand response programs. Details on five

incentive programs are available at: <http://www.poweritsolutions.com/blog/?detail=yes&id=420>.

Where incentive programs aren't available, renting, renting to own, and leasing often are attractive alternatives to outright purchases. These financing options increase purchasing power and lower the upfront investment, allowing immediate action on reducing energy costs, even when there's no budget for new technology. Depending on the circumstances, businesses may be able to realize tax benefits through bonus and accelerated depreciation or investment tax credits, and can even realize immediate positive cash flow. **BP**

#### ABOUT THE AUTHOR

*Bob Zak is general manager and president of Powerit Solutions North America, a Seattle-based international cleantech company whose Spara energy management system allows energy-intensive businesses to take full advantage of the smart grid. Zak is a member of the controls experts group working with Lawrence Berkeley National Laboratory to advance Auto-DR and other smart grid initiatives. Early in the development of OpenADR, Powerit worked closely with the Lab to put the new standard into practical use at commercial and industrial sites. To learn more about Powerit Solutions, visit [www.poweritsolutions.com](http://www.poweritsolutions.com) or call 206.467.3030 or toll-free 866.499.3030.*

# ENERGY KAIZEN EVENTS

➤ Food Packaging Plant Saves \$70,000 or 1.1 Million kWh per year.

➤ Paper Mill Saves \$207,000 or 4.5 Million kWh per year.



Get your **FREE** Subscription to Compressed Air Best Practices® Magazine to **learn how to save energy.**

Subscribe at  
[www.airbestpractices.com](http://www.airbestpractices.com)



# RESOURCES FOR ENERGY ENGINEERS

## TRAINING CALENDAR

TITLE	DATE	LOCATION	SPONSOR(S)
<a href="http://www.compressedairchallenge.org">Visit www.compressedairchallenge.org for more information.</a>			
Fundamentals of Compressed Air Systems	September 20, 2011	Cedar Rapids, IA	Iowa Energy Center and the Compressed Air Challenge
Fundamentals of Compressed Air Systems	September 21, 2011	Ames, IA	Iowa Energy Center and the Compressed Air Challenge
Advanced Management of Compressed Air Systems	September 22–23, 2011	Ames, IA	Iowa Energy Center and the Compressed Air Challenge
Fundamentals of Compressed Air Systems	September 27, 2011	Portland, OR	Rogers Machinery and Compressed Air Challenge
Fundamentals of Compressed Air Systems	October 11, 2011	Navy Pier WEEC 2011, Chicago, IL	Association of Energy Engineers, USDOE, Compressed Air Challenge
AirMaster+ Specialist Qualification	October 11–14, 2011	Stockton, CA	Pacific Gas and Electric, California Energy Commission
Fundamentals of Compressed Air Systems WE (web-edition)	November 9, 2011	Online Training	Compressed Air Challenge

*Editor's Note: If you conduct compressed air system training and would like to post it in this area, please email your information to [rod@airbestpractices.com](mailto:rod@airbestpractices.com).*

## COMPANY NEWS

### New Company Announcement

nano-purification solutions, a recently formed business located in North Carolina, has partnered with nano porous systems, ltd. based in the Northeast of England to establish a North American hub for the nano brand of products. In addition to the compressed air and gas treatment products manufactured at the Gateshead facility the new businesses product offering includes a broad range of purification, dehydration, and condensate purification solutions for the industrial market. Founded on principles of experienced application knowledge, strong technical support, and superior customer service, the business promotes a strategy of a positive experience — driven by capable dedicated people, and backed by innovative solutions, which meet their customer's expectations.

**Contact nano – purification solutions (n-psi)**

11330 Vanstory Drive  
Huntersville, NC 28078  
PH (704) 897-2182  
Email: [support@n-psi.com](mailto:support@n-psi.com)  
Website: [www.n-psi.com](http://www.n-psi.com)







**BREAK  
ING THE  
MOLD**

## RESHAPE THE FUTURE OF PLASTICS

From the plastics of today to the engineered materials of tomorrow, our industry unites in 2012 to Break the Mold at The International Plastics Showcase. For the first time ever, professionals from around the world will gather in Orlando to uncover the latest tools and techniques needed to reshape the industry itself — and continue our impressive evolution.

Make plans now to participate in NPE2012 and see the latest in bio-renewable thermoplastics, injection molding, polymer nanocomposites, nanofibers and the green technologies that are changing the way we do business. Join tens of thousands of like-minded professionals to share success stories and explore solutions to the exciting challenges we face today and tomorrow.

The must-attend NPE2012 promises to deliver everything plastics — and your greatest opportunity to reshape your organization for maximum productivity.

Visit us online at [www.npe.org](http://www.npe.org).

### The International Plastics Showcase

April 1–5, 2012 | [www.npe.org](http://www.npe.org)

Orange County Convention Center  
Orlando, Florida USA



## RESOURCES FOR ENERGY ENGINEERS

### PRODUCT NEWS

#### DV Systems Introduces New Air Compressor

DV Systems has introduced a new 10 horsepower (37 cfm), single-phase, 230V, rotary screw air compressor that operates at 55 amps. The Variable Speed Drive control allows for a soft start ramp-up eliminating high start-up amp draw. The VSD will smoothly adjust the motor speed based on air demand to maximize energy efficiency.

The VS20 controller features a bright LCD display and the air compressor has a high quality North American TEFC industrial electric motor. Sound attenuation to 68 dBA is provided by a powder-painted enclosure. The package comes on a 80-gallon receiver built to ASME codes and is CRN registered. A refrigerated air dryer and ceramic pre-filter is included. The air compressor has a 5 Year Limited Warranty.



#### **Contact DV SYSTEMS**

*Tel: 705 728-5657*

*Fax: 705 728-4974*

*Toll free: 800 668-8558 (Canada)*

*Toll Free: 877-687-1982 (U.S.A.)*

*Email: sales@dvsystems.ca*

*www.dvsystems.ca*

#### Atto Super Air Nozzle for Precise Blowoff

EXAIR's new Atto Super Air Nozzle™ has been engineered to produce the highest performance attainable from a tiny nozzle. It delivers the smallest, most precise blowoff with an efficient, high volume, high velocity airflow. The overall length of the air nozzle measures only 0.50" (12.7mm) with a diameter of only 0.16" (4mm), permitting installation in tight spaces. The durable Type 316 stainless steel construction is suitable for blowoff, cooling and drying applications located in general industrial, high temperature, food, pharmaceutical, semiconductor or corrosive environments.

The Model 1108SS Atto Super Air Nozzle provides a narrowly focused air pattern. High amplification of airflow and a strong blowing force of 2.0 ounces (56.7 grams) are achieved with minimal air consumption of 2.5 SCFM at 80 PSIG. Safe operation is assured since the airflow of the Atto Super Air Nozzle cannot be blocked, which meets the OSHA standard for dead-end pressure 29 CFR 1910.242(b). Sound level is very low at 58 dBA and meets OSHA noise requirement 29 CFR 1910.95(a), as well as being CE compliant.

The Atto Super Air Nozzle is designed to easily replace existing wasteful nozzles or open pipes. The compressed air inlet is male M4 X 0.5. Price is \$36.



#### **Contact EXAIR Corporation**

*Phone: (800) 903-9247*

*Fax: (513) 671-3363*

*E-mail: techhelp@exair.com*

*www.exair.com/attosan.htm*

# Energy Efficient Hydraulics and Pneumatics Conference

November 15-17, 2011

Sheraton Chicago O'Hare Airport Hotel, Rosemont, Illinois



THE FPDA   
MOTION & CONTROL NETWORK



Hosted by the International Fluid Power Society (IFPS), the FPDA Motion and Control Network (FPDA), and the National Fluid Power Association (NFPA)

## *Saving energy and money with fluid power*

This first-of-its-kind event is designed for engineers and technicians who seek information on how to design and maintain energy efficient hydraulic and pneumatic systems, within these fluid power end-use markets:

- Agricultural Machinery
- Automotive
- Chemical Processing
- Class 4-8 Trucks
- Construction Machinery
- Food Processing
- Lawn & Garden
- Material Handling
- Medical Equipment
- Metalworking and Machine Tools
- Mining Machinery
- Off-Shore Drilling
- Oil & Gas Machinery
- Packaging Machinery
- Plastics Machinery
- Paper Machinery
- Power Generation
- Printing Machinery
- Semiconductor
- Wind Power
- and many more

*Fluid power (hydraulics and pneumatics) is used in dozens of industries and hundreds of applications to precisely control the movement of machinery and material. Yet many engineers and technicians working in those industries do not fully understand the design concepts critical to developing efficient fluid power systems and the diagnostic and maintenance techniques essential to keep those systems operating at peak efficiency. These concepts and techniques can result in significant energy and cost savings for companies that use hydraulics or pneumatics, as well as for the customers they serve, making fluid power a more competitive technology choice.*

The conference schedule will include **breakthrough presentations** from fluid power component manufacturers, distributors, and system integrators, showcasing innovative approaches and emerging technologies in energy efficient fluid power design and maintenance.

**Networking events** are being organized to help participating engineers and technicians engage with technology providers from fluid power manufacturing and distribution companies.

**Sponsorship opportunities** will be available for fluid power manufacturers and distributors, and other companies interested in supporting this event and connecting with engineers and technicians from a wide array of fluid power's end-use market industries.

**For all the details and how to register, go to [www.nfpa.com/Events/EEHPC.htm](http://www.nfpa.com/Events/EEHPC.htm).**

## RESOURCES FOR ENERGY ENGINEERS

### PRODUCT NEWS

#### Ingersoll Rand Expands R-Series Line of Rotary Screw Air Compressors

Ingersoll Rand has expanded its contact-cooled rotary screw air compressor line with the R-Series 55–75 kW / 75–100 hp range. The new range is available in fixed speed and Nirvana variable speed drive at capacities up to 3.23–13.56 m<sup>3</sup>/min (114–479 cfm).

“With the 55–75 kW range of R-Series compressors, we are able to introduce new features and options that deliver reliability, efficiency and productivity for our customers, while providing the same industry-leading benefits offered by the larger 90–160 kW R-Series compressor range,” said Robert Horneman, global portfolio manager for Ingersoll Rand.

The new range of compressors is equipped with the Xe-Series controller, which features a high resolution LCD color display that provides immediate and intuitive access to all vital compressor data and settings. Further, the controller allows access and remote control of the compressor from any PC, tablet or smartphone via the internet and can send automatic email notifications of trips and warnings.

The integrated Total Air System (TAS) dryer and filtration option provides clean, dry air in a single package, minimizing installation costs and footprint while allowing single-point maintenance and monitoring for the complete system. The Total Air System option comes with refrigerated dryer technology and a high efficiency coalescing filter to deliver ISO Class 1-4-2 quality air. The TAS option utilizes a patented 3-in-1 heat exchanger, which improves energy efficiency and lowers operating cost when compared to traditional stand-alone dryers.

In addition to the new Xe-Series controller and TAS option, the 55–75 kW R-Series range boasts the same advanced features introduced with the larger 90–160 kW / 125–200 hp range: PACTM protection, V-Shield™ technology, and sequential cooling. Progressive Adaptive Control™ (PAC) protection is an integrated, intelligent system that monitors filtration, ambient temperature and other



parameters and adapts the operation of the compressor in order to reduce energy consumption, lower noise and increase uptime. V-Shield technology is a superior configuration using stainless steel pipes, durable metal-flex hoses and a vibration isolation system to eliminate possible leak paths. Sequential cooling utilizes a centrifugal blower, which consumes less energy and operates much quieter than traditional cooling fans.

R-Series compressors are designed for reduced maintenance and easy serviceability. By utilizing swing out separator covers, longer life consumables, easy-access hinged doors, single side maintenance access and slide out coolers, the time needed to service and maintain the compressors has been significantly reduced.

#### **Contact Ingersoll Rand**

<http://www.ingersollrandproducts.com/rseries/55-75.aspx-item-38154>.

# COMPRESSED AIR BEST PRACTICES

## FREE SUBSCRIPTION

DIGITAL EDITION FREE WORLDWIDE | PRINT EDITION FREE TO U.S. SUBSCRIBERS



## 2011 FOCUS INDUSTRIES!

Concrete Bulk Handling • Pharmaceutical • Automotive Manufacturing • Lumber, Pulp & Paper • System Assessments  
Plastics Blow Molding • Food Packaging • Wastewater Treatment • Food Processing • Air Compressor Controls & Monitoring

### Sustainable Energy Savings for Compressed Air Best Practices®

Compressed Air Best Practices® is a technical magazine dedicated to discovering **Energy Savings** and **Productivity Improvement Opportunities** in compressed air systems for specific **Focus Industries**. Each edition outlines “Best Practices” for compressed air users — particularly those involved in **managing energy costs in multi-factory organizations**.

Utility and energy engineers, utility providers and compressed air auditors share techniques on how to audit the “demand side” of a system — including the **Pneumatic Circuits** on machines. This application knowledge allows the magazine to recommend “**Best Practices**” for the “supply side” of the system. For this reason, we feature **air compressor, air treatment, measurement and management, pneumatics, blower and vacuum** technologies as they relate to the requirements of the monthly **Focus Industry**.

- **Compressed Air Users — Focus Industry**
  - A. Energy and utility managers share experiences
  - B. Audit case studies and “Best Practice” recommendations
- **Utility Providers & Air Auditors**
  - A. Utility company rebate programs
  - B. Case studies by expert compressed air auditors
- **Compressed Air Industry**
  - A. Profiles of manufacturers and distributors
  - B. Product technologies best suited for the focus industries
  - C. Industry news

To subscribe visit [www.airbestpractices.com](http://www.airbestpractices.com)

*International pricing for print edition — \$65 in Canada and \$95 for other countries.*



# WALL STREET WATCH

BY COMPRESSED AIR BEST PRACTICES®

The intent of this column is to provide industry watchers with publicly held information, on publicly held companies, involved with the sub-industry of compressed air. It is not the intent of the column to provide any opinions or recommendations related to stock valuations. All information gathered in this column was during the trading day of October 26, 2011.

OCTOBER 26, 2011 PRICE PERFORMANCE	SYMBOL	OPEN PRICE	1 MONTH	6 MONTHS	12 MONTHS	DIVIDEND (ANNUAL YIELD) 12 MONTHS
Parker-Hannifin	PH	\$79.16	\$62.75	\$96.71	\$76.51	1.91%
Ingersoll Rand	IR	\$30.03	\$31.39	\$50.77	\$39.51	1.62%
Gardner Denver	GDI	\$77.00	\$66.02	\$84.59	\$59.04	0.26%
Atlas Copco ADR	ATLCY	\$19.22	\$15.61	\$25.59	\$18.78	3.49%
United Technologies	UTX	\$76.39	\$69.87	\$87.91	\$74.47	2.55%
Donaldson	DCI	\$63.00	\$55.90	\$60.56	\$49.50	0.96%
SPX Corp	SPW	\$53.40	\$47.11	\$83.75	\$68.77	1.90%

## Gardner Denver Announces Agreement to Acquire Robuschi

**Gardner Denver, Inc. (NYSE: GDI)** announced that it has entered into a share purchase agreement with the holders of 100% of the outstanding shares of Robuschi S.p.A. (“Robuschi”), a market leading European manufacturer of blowers and pumps, for a purchase price of approximately EUR 152 million (\$207 million at current exchange rates). Robuschi is headquartered in Parma, Italy, and has annual revenues of approximately EUR 70 million (\$95 million). Its shares are currently held by an investor group led by Milan, Italy based Aksia Group.

Robuschi is a leading European producer of blowers, pumps and associated packages. These products are used in a wide variety of end markets including wastewater, mining, and power generation, as well as general industrial applications. With facilities in Noceto, Italy; Sao Paulo, Brazil; and Shanghai, China, in addition to its main production facility in Parma, Robuschi serves

over 3,000 customers and has an installed base in excess of 200,000 units.

“Robuschi is an outstanding strategic addition to the Gardner Denver portfolio and an excellent fit with our Industrial Products Group,” stated Barry L. Pennypacker, President and Chief Executive Officer of Gardner Denver. “Robuschi’s advanced manufacturing capabilities are expected to enable significant cost synergies as we continue to optimize our European manufacturing footprint supported by the principles of the Gardner Denver Way. I would like to welcome the talented employees of Robuschi to the Gardner Denver family and I look forward to developing the strong Robuschi brand name globally.”

The transaction is subject to customary closing conditions, including the receipt of applicable regulatory approvals, and is expected to close in the fourth quarter of 2011.

### Atlas Copco Completes Acquisition of the German Adhesive Equipment Manufacturer SCA Schucker

SCA Schucker manufactures adhesive and sealant equipment, a relatively large niche segment with few global specialized players. The market is expanding fast due to the increasing use of lightweight materials in the automotive and other industries. The company had sales of MEUR 65 (MSEK 600) in 2010 and about 280 employees. The acquired business now operates as a separate business line within the business area Industrial Technique's Motor Vehicle Industry division.

### Donaldson Reports Record Fourth Quarter and Full-Year Results

Donaldson Company, Inc. (NYSE: DCI) announced its financial results for its fiscal 2011 fourth quarter. Summarized financial results are as follows (dollars in millions, except per share data):

	THREE MONTHS ENDED JULY 31			TWELVE MONTHS ENDED JULY 31		
	2011	2010	CHANGE	2011	2010	CHANGE
Net sales	\$625	\$515	21%	\$2,294	\$1,877	22%
Operating income	90	75	21%	315	238	32%
Net earnings	66	51	29%	225	166	36%
Diluted EPS	\$0.84	\$0.65	29%	\$2.87	\$2.10	37%

“We are very pleased to report that we had a very good 4th quarter with all-time quarterly sales and EPS records. We also delivered full year records on key operating metrics including sales, operating margins, and net earnings,” said Bill Cook, Chairman, President and CEO. “We saw strength in both of our reporting segments as Engine and Industrial Products sales increased 26% and 15% over the prior year, respectively. Our operating margin was 14.4% in the fourth quarter and a record 13.7% for the year. We are executing very well in our manufacturing plants and distribution centers and continue to make both capital and operating investments which, along with our *Continuous Improvement* initiatives, position us to profitably support our Customers’ global growth plans.”

“Over the past four weeks, there have been many reports of a slowdown in global growth rates and the increased possibility of another recession. However, our current order trends remain healthy and, consequently, we continue to forecast that our sales will grow 7 to 15% in FY12. However, we will remain very vigilant and will quickly modify our plans if conditions change. Through our continued execution of our Strategic Growth Plans and by focusing on those things



“ I would like to welcome the talented employees of Robuschi to the Gardner Denver family and I look forward to developing the strong Robuschi brand name globally.”

— Barry L. Pennypacker, President and Chief Executive Officer of Gardner Denver

## WALL STREET WATCH

we can control, we forecast delivering another sales record and record EPS performance of between \$3.15 and \$3.45 per share in FY12.”

### Financial Statement Discussion

The impact of foreign currency translation increased sales by \$40.3 million, or 7.8%, during the fourth quarter and \$49.8 million, or 2.7%, for the year. The impact of foreign currency translation increased reported net earnings by \$4.0 million, or 7.7%, during the fourth quarter and \$6.1 million, or 3.6%, for the year.

Gross margin was 36.3% for the quarter, equal to last year’s fourth quarter, and 35.5% for the year, 40 basis points better than last

year’s 35.1%. Increases in purchased raw material and freight costs were offset by better fixed cost absorption and our Continuous Improvement initiatives.

Operating expenses for the quarter were \$137.0 million, or 21.9% of sales, versus \$112.4 million, or 21.8% of sales, last year. Operating expenses for the year were \$498.5 million, or 21.7% of sales, compared to \$420.5 million, or 22.4% of sales, last year.

As part of our ongoing share repurchase program we repurchased 1,157,000 shares for \$65.8 million during the quarter. For the year, we repurchased 1,957,000 shares, or 2.5% of our diluted outstanding shares, for \$108.9 million.

### FY12 Outlook

We expect continued expansion in many of our end markets, with higher growth in emerging economies. We are planning our FY12 sales to be between \$2.45 and \$2.60 billion, or up about 7 to 15% from the prior year. Our current forecast is based on the Euro at US\$1.42 and 81 Yen to the US\$.

- Our full year operating margin is forecasted to be 13.7 to 14.5%
- We forecast our full year FY12 EPS to be between \$3.15 and \$3.45
- Cash generated by operating activities is projected to be between \$275 and \$305 million in FY12. Capital spending is estimated to be approximately \$100 million

**Industrial Products:** We forecast full year sales to increase 7 to 15%, including the impact of foreign currency translation.

- Our Industrial Filtration Solutions’ sales are projected to increase 7 to 14% assuming demand for new filtration equipment and replacement filters both continue to improve with increased global general industrial capital activity and spending
- We anticipate our Gas Turbine Products’ sales to be up 14 to 22% due to an improvement in the power generation market and ongoing strength in the oil and gas market segment
- Special Applications Products’ sales are forecast to increase 2 to 9% primarily due to growing sales of our membranes products 

## COMPRESSED AIR BEST PRACTICES® www.airbestpractices.com

### ADVERTISER INDEX

Company	Page	Web Site
Kaeser Compressors	Outside Back Cover	kaeser.com/ADA
World Energy Engineering Conference	Inside Back Cover	www.aeecenter.org
Atlas Copco Front Cover	Inside	www.atlascopco.us/danielusa
Hitachi	3	www.hitachi-america.us/airtech
Sullair	5	www.sullair.com
SPX Hankison	7	www.hankisonintl.com
Chicago Pneumatic	9	www.cp.com
EDMAC	11	www.edmac.com
CDI Meters	13	www.cdimeters.com
JORC Industrial	15	www.jorc.com
Vaisala	17	www.vaisala.com/dds
Aerzen	19	www.aerzenusa.com
BEKO Technologies	21	www.bekousa.com
Domnick microBAN	23	www.domnickmicroban.com
Sullivan-Palatek	25	www.sullivanpalatek.com
Ultrachem Lubricants	29	www.ultracheminc.com
Gardner Denver	31	savewithgardnerdenver.com
Association of Facilities Engineers	35	www.afe.org/benefits
NPE 2012	41	www.npe.org
NFPA Conference	43	www.nfpa.com/Events





# THE JOB MARKET

## JOB OPPORTUNITIES



### COMPRESSOR SALES MANAGER

IDEX Corporation is looking for a **Compressor Sales Manager** for its Corken facility in Oklahoma City, OK. Base location is flexible. Sales territory will include North America and Canada. Candidates need to have extensive compressed air background, and knowledge of distribution channels. Additional details upon interview.

**Website:** [www.corken.com](http://www.corken.com)

**Send resumes to:** [terlenbaugh@idexcorp.com](mailto:terlenbaugh@idexcorp.com)



### AIR COMPRESSOR TECHNICIAN

I & M Industrials, Inc. is looking to hire a professional air compressor / refrigeration technician to cover the low country of South Carolina. Ideal candidate will have a strong mechanical, refrigeration or electrical background with the ability to troubleshoot compressed air systems. Must be a self-starter.

This position will be based out of the Charleston, South Carolina area and require travel in the lower portion of the state. Pay commensurate with ability. Competitive benefit package includes: Insurance, 401K with company contributions, Company Service Truck.

Contact Ron Turner at (864) 277-2450 or email resume to [sales@iandminindustrials.com](mailto:sales@iandminindustrials.com) with "Attention Ron" in subject line.

**Website:** [www.iandminindustrials.com](http://www.iandminindustrials.com)



### REGIONAL SALES MANAGER

Midwest Control is looking for a Regional Sales Manager to be based in the Chicagoland area.

This is an excellent opportunity for an aggressive self-starter to bring creative sales talents into the industrial sales market. In an established territory, you will represent a fluid power distributor specializing in calling on the air compressor market selling pneumatic relief valves, check valves, ball valves, filters, regulators, lubricators and various other pneumatic components. Knowledge of the fluid power market is required. Salary commensurate with experience plus commission, car and expenses.

**Send resumes to:** [kdrexler@midwest-control.com](mailto:kdrexler@midwest-control.com)

## HITACHI Inspire the Next

### DISTRIBUTION AREA MANAGER

Hitachi America is looking for a Distribution Area Manager. Based in **Charlotte, NC**, this person will be responsible for developing sales of Hitachi Air Technology Products through existing and newly developed relationships with North American distributor organizations.

For more information or to submit your resume, visit: <https://hal.tms.hrdepartment.com/jobs/119/Distribution-Area-ManagerCharlotte-NC>

Contact Rod Smith for ad rates:

[rod@airbestpractices.com](mailto:rod@airbestpractices.com),  
Tel: 412-980-9901



### DISTRICT MANAGER - MIDWEST

BOGE America is looking for a District Manager for the Midwest Territory. Compressed air experience is a must to be considered for this position. This position requires significant travel and the ability to be self motivated, organized, goal oriented, and outstanding communication skills. Primary job responsibilities include working with the existing distributor network, expanding distributor network, support and training of distributors, and other tasks to reach territory sales goals.

Please send your resume and cover letter to Scott Woodward at [s.woodward@boge.com](mailto:s.woodward@boge.com).

## COMPRESSED AIR BEST PRACTICES® [www.airbestpractices.com](http://www.airbestpractices.com)

**Advertising & Editorial** : **Rod Smith**  
[rod@airbestpractices.com](mailto:rod@airbestpractices.com)  
Tel: 412-980-9901

**Subscriptions & Administration** : **Patricia Smith**  
[patricia@airbestpractices.com](mailto:patricia@airbestpractices.com)  
Tel: 412-980-9902

**A Publication of** : **Smith Onandia Communications LLC**  
217 Deer Meadow Drive  
Pittsburgh, PA 15241

Compressed Air Best Practices® is published monthly by Smith Onandia Communications LLC., 217 Deer Meadow Drive, Pittsburgh, PA 15241. Phone 412-980-9902, email [patricia@airbestpractices.com](mailto:patricia@airbestpractices.com). Compressed Air Best Practices® is a trademark of Smith Onandia Communications, LLC. Publisher cannot be held liable for non-delivery due to circumstances beyond its control. No refunds. Standard postage is paid at 233 Jefferson Street, Greenfield, Ohio 45123. Canadian and international distribution: IMEX International Mail Express, 1842 Brummel Drive, Elk Grove Village, IL 60007. POSTMASTER: Send address changes to Compressed Air Best Practices®, 217 Deer Meadow Drive, Pittsburgh, PA 15241. SUBSCRIPTIONS: Qualified reader subscriptions are accepted from compressed air professionals, plant managers, plant engineers, service and maintenance managers, operations managers, auditors, and energy engineers in manufacturing plants and engineering/consulting firms in the U.S. To apply for qualified reader subscriptions, please fill in the reader response cards herein and mail or fax or go to [www.airbestpractices.com](http://www.airbestpractices.com). To non-qualified subscribers subscriptions are \$65 in Canada and \$95 for other countries. When available, extra copies of back issues are \$4 plus shipping. Contact Patricia Smith for subscription information at Tel: 412-980-9902 or email: [patricia@airbestpractices.com](mailto:patricia@airbestpractices.com). REPRINTS: Reprints are available on a custom basis, contact Patricia Smith for a price quotation at Tel: 412-980-9902 or email: [patricia@airbestpractices.com](mailto:patricia@airbestpractices.com). All rights are reserved. The contents of this publication may not be reproduced in whole or in part without consent of Smith Onandia Communications LLC. Smith Onandia Communications LLC does not assume and hereby disclaims any liability to any person for any loss or damage caused by errors or omissions in the material contained herein, regardless of whether such errors result from negligence, accident, or any other cause whatsoever. Printed in the U.S.A.



# THE MARKETPLACE

## TECHNOLOGY

### PROVEN DATA LOGGING SOLUTIONS

## Where are the Cost Savings?



Non-invasive Install  
Tell-all Graphical Proof

Bad electricity usage wastes energy not to mention being bad for the environment. ACR Electric Current Data Loggers reveal the information needed to make informed decisions on energy conservation **24/7 - 365** days a year.

Best Warranty and Customer Service



Tel: 604.591.1128  
Toll-Free: 1.800.663.7845  
Email: info@acrsystems.com

ISO 9001:2000

[www.acrsystems.com/374](http://www.acrsystems.com/374)

**BELT OIL SKIMMERS** lift and collect oil floating on water in pits, drums or wells! Big selection of types & collection rates! 1-800-255-5665  
[www.wayneproducts.com](http://www.wayneproducts.com)  
info@wayneproducts.com

## COMPRESSED AIR BEST PRACTICES® MARKETING SERVICES

### MARKETING SERVICES FOR COMPRESSOR DISTRIBUTORS & OEMS

We Make Marketing Easy With Our Lead-Gen Triathlon Model

1. IDENTIFY CUSTOMER NEEDS
2. CREATE CONTENT-OF-VALUE
3. CONTENT DELIVERY

Contact Rod Smith for a personalized proposal.  
rod@airbestpractices.com, Tel: 412-980-9901

## The BOGE Booster

The ideal solution for generating up to 600 psi within a compressed air network.



We are looking for distributors nationwide for the oil-free and oil-lubricated piston BOGE Booster product range. Why not join our team?



To learn more about the BOGE Booster, contact Scott Woodward at 770-874-1570 or visit [www.boge.com/us](http://www.boge.com/us)

## Eldridge Products, Inc. Thermal Mass Flowmeters

From HVAC to Compressed Air to PET Blow Molding or just about anything in between . . . if you're flowing Air, you can measure it with a

### Master-Touch™



Eldridge Products, Inc.  
2700 Garden Road  
Monterey, CA 93940  
T: 831.648.7777  
F: 831.648.7780  
sales@epiflow.com  
www.epiflow.com



## Universal AutoDual Compressor Controllers

Control Rotary Screw, Vane, Scroll or Recip Compressors



Save Energy controlling up to three compressors and qualify for Utility Rebates.

- Automatic Lead/Lag Control
- Pressure Control with Pressure Transducers
- Compressors from 2 to 250 hp

Thousands of Installations Worldwide. Call for Application Engineering.

Standard Pneumatic Products, Inc.  
Tel: 203-270-1400 • Toll free: 800-979-9156  
Email: sales@stdpneumatics.com

[www.stdpneumatics.com](http://www.stdpneumatics.com)



Rebuild all brands, makes, models of Air Ends, Blowers and Gear Boxes

Sample of The PROS Company work.



Before & After

The PROS Company  
601 Texas Avenue  
Lubbock, Texas 79401  
806-749-7761 (PRO1)

[www.thePROSCO.com](http://www.thePROSCO.com)  
repairyouairend@thePROSCO.com



# UPCOMING ENERGY SHOWS

ATLANTIC CITY • SEATTLE • ATLANTA



**March 7-8, 2012**  
**Atlantic City**  
**Convention Center**  
**Atlantic City, NJ**

Globalcon 2012, presented by the Association of Energy Engineers, is designed specifically to facilitate those who need to get up to speed on the latest developments in the energy field, explore promising new technologies, compare energy supply options, engage energy management initiatives and learn about innovative and cost-conscious project implementation strategies.

Featuring



Platinum Sponsor



Forward Thinking Energy



Bronze Sponsor



White Star Corporate  
 Energy Leader



[www.globalconevent.com](http://www.globalconevent.com)



**May 23-24, 2012**  
**Washington State**  
**Convention & Trade**  
**Center**  
**Seattle, WA**

The West Coast Energy Management Congress, is the largest energy conference and technology expo held on the U.S. West Coast specifically for business, industrial and institutional energy users. It brings together the top experts in all areas of the field to help you set a clear, optimum path to both energy cost control and energy supply security.

Hosted by



Featuring



Platinum Sponsor



Bronze Sponsors



BETTERBRICKS  
 An initiative of the Northwest Energy Efficiency Alliance.

[www.energyevent.com](http://www.energyevent.com)

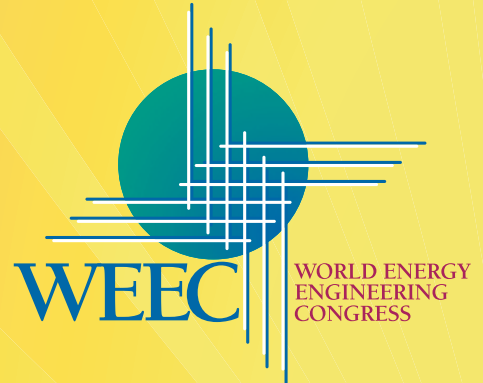

**Oct. 31 - Nov. 1, 2012**  
**Georgia World**  
**Congress Center**  
**Atlanta, GA**

Now in its 35th year, the World Energy Engineering Congress, is recognized as the most important energy event of national scope for end users in all areas of the energy field. A comprehensive forum where you can assess the "big picture" and see exactly how the economic and market forces, new technologies, regulatory developments & industry trends all merge.

**Green Street** EXPO AT WEEC  
 Sponsored By LEARN MORE AT [energystar.gov](http://energystar.gov)

WEEC's highly acclaimed **GreenStreet expo showcase**, introduced in 2007 and co-presented by the U.S. EPA's ENERGY STAR®, will again be a prominent part of the WEEC for 2012. Here you can examine firsthand the latest green / sustainable / environmentally friendly energy technologies now available for both new design and retrofit projects. Conference presentations will facilitate your understanding of these technologies, covering such topics as green building design and retrofit; LEED certification and building commissioning; high performance facilities; federal initiatives; state and local sustainable development programs; the latest developments in renewable energy; reducing carbon emissions; transportation solutions for the future; and green/sustainable project success stories.

[www.energycongress.com](http://www.energycongress.com)

**KAESER  
COMPRESSORS**

*Built for a lifetime.™*

***“Beware of small expenses. A small leak will sink a large ship.”***

*Benjamin Franklin*

**Your compressed air system may cost you more than you think.**

It takes more than good equipment to make an efficient air system. That's why our air system specialists are here for you. We look beyond the basics to find savings in the whole system and determine what you need to run at peak performance.

Kaeser's compressed air energy audits stand out in the industry for completeness and accuracy. Our **Air Demand Analysis (ADA)** will identify and help you eliminate inefficiencies related to controls, leaks, artificial demand, inadequate piping, and storage – as well as reduce waste and scrap caused by inconsistent pressure in production equipment. It will also help you cut maintenance costs by optimizing run time and reducing excess cycling. ADA documentation will even help you apply for electric utility rebates.

Add in superior products plus our reputation for strong customer service, and it's no wonder Kaeser delivers the best value. Let us to put our expertise to work for you.

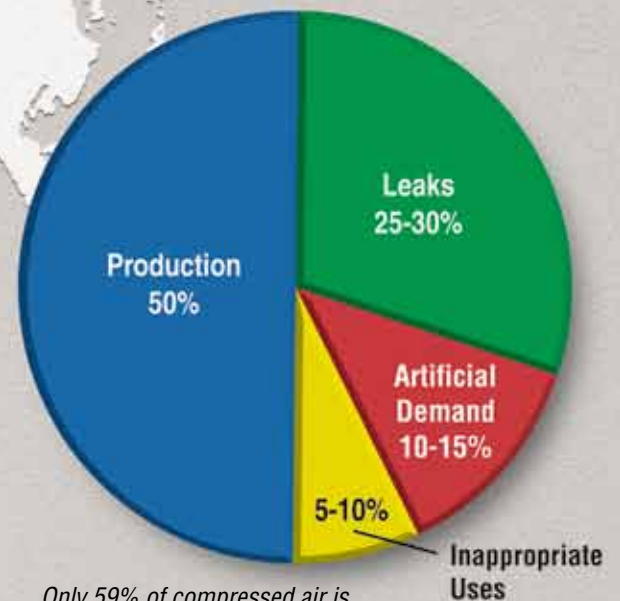

*Only 59% of compressed air is actually put to productive use.*



Scan this code for more info.

**Kaeser Compressors, Inc. • 800-777-7873 • [kaeser.com/ADA](http://kaeser.com/ADA)**

*Built for a lifetime* is a trademark of Kaeser Compressors, Inc. ©2011 Kaeser Compressors, Inc.

**kaeser.com**